

99.3

99.2

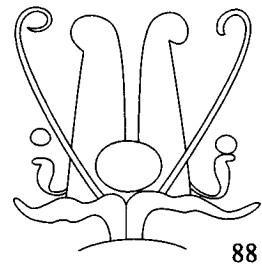

88

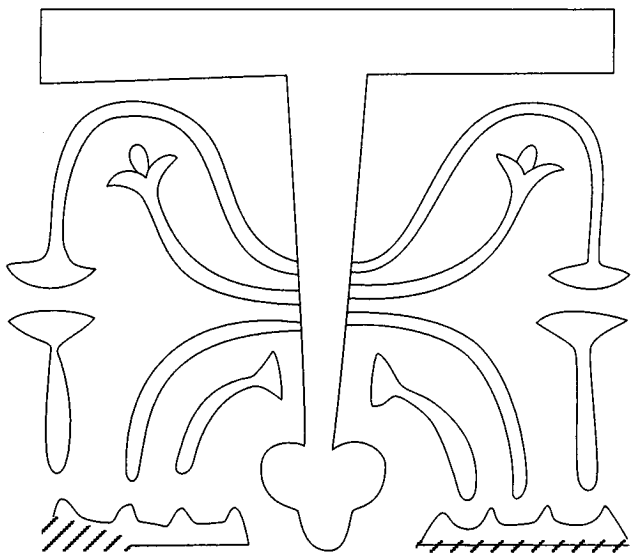
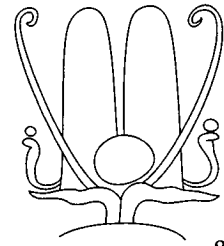

89

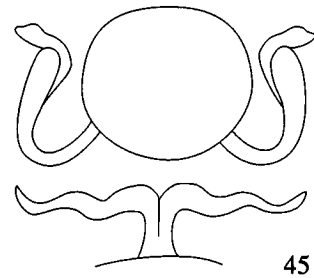

45

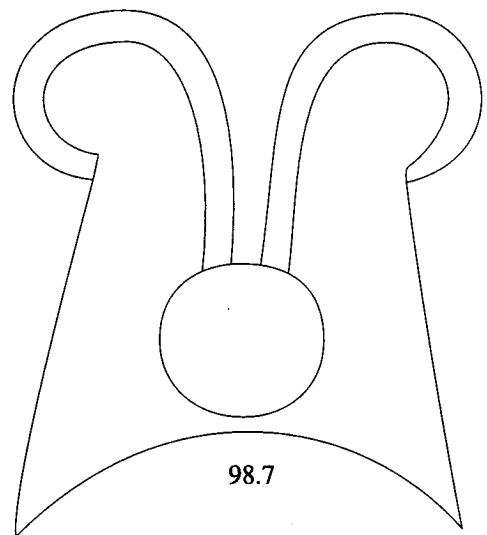

98.7

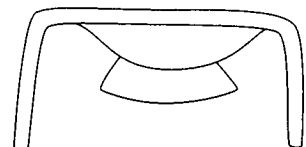

46

Der Kartuschenschmuck (Maßstab 1:2,5)



Sarapiskopf aus dem 2. Hof
(Alabaster)



Gußform in Ton aus der "Festung"













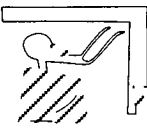

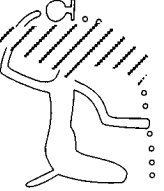
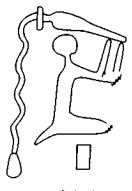







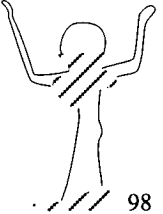
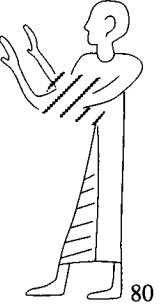
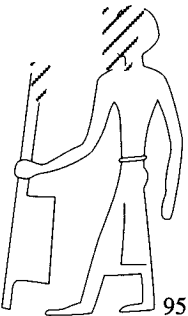
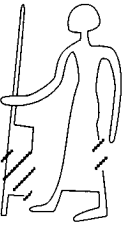

Zwei Tafelchen aus dem Schatzfund



Der Naiskos der goldenen Krone

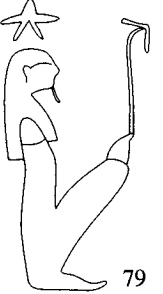

Darstellungen von Osiris (Sarapis), Isis und Harpocrates aus Dusch in hellenistischem Stil

<p>1-5</p>	<p>A. Männer</p>  <p>70.2</p>  <p>5</p>  <p>84.7</p>  <p>81.1</p>  <p>81.8</p>
<p>6-11</p>	 <p>81.9</p>  <p>74.3</p>  <p>5</p>  <p>1.15</p>  <p>1.4</p>  <p>61.2</p>
<p>12-16</p>	 <p>98</p>  <p>80</p>  <p>95</p>  <p>83.5</p>  <p>29.2</p>
<p>17-22</p>	<p>B. Frauen</p>  <p>6</p>  <p>69.4</p> <p>C. Gottheiten</p>  <p>29.1</p>  <p>84.1</p>  <p>98</p>  <p>97.5</p>
<p>23-27</p>	 <p>79</p>  <p>98</p>  <p>29.2</p>  <p>62.1</p>  <p>94</p>

28-32

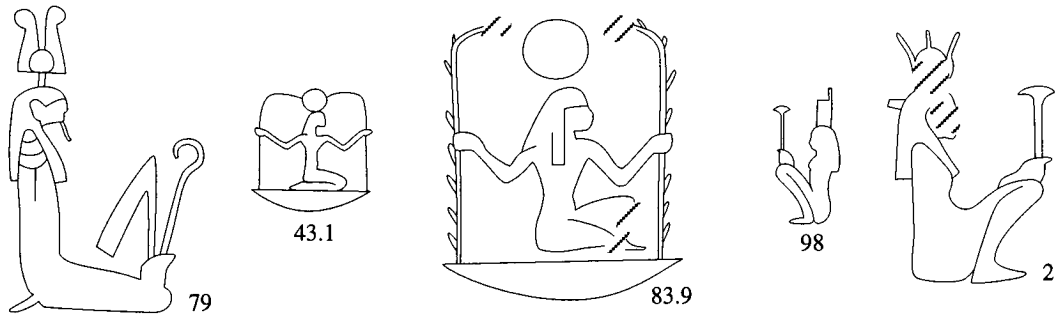

D. Menschliche Körperteile

33-38

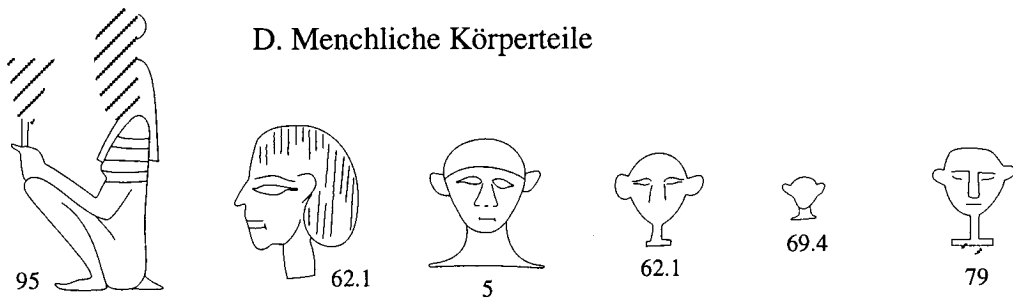

39-44

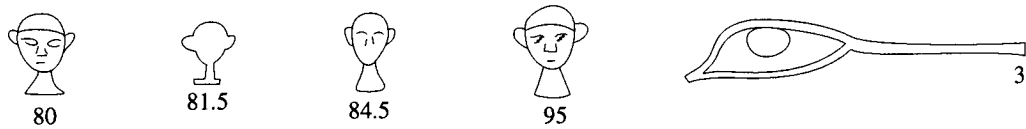

45-48

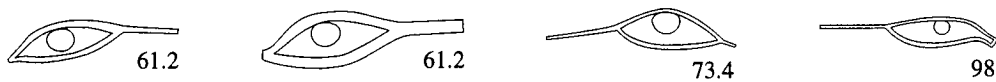

49-53

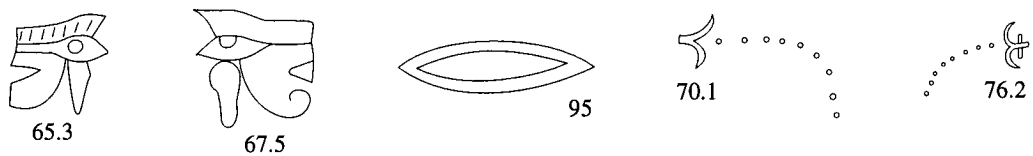

54-58

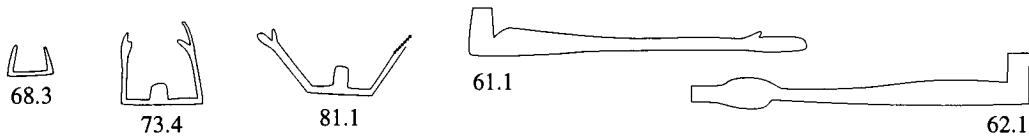

59-62

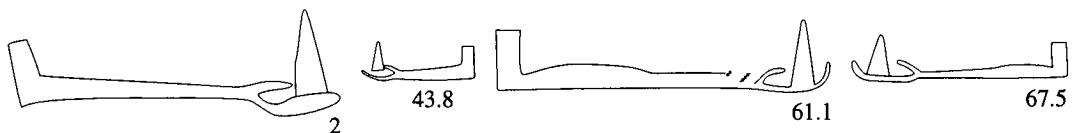

63-67



68-71

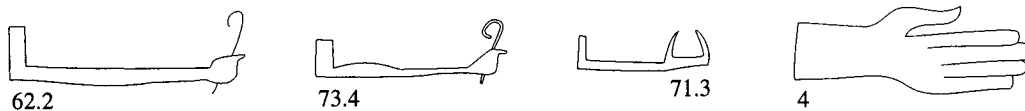

72-75

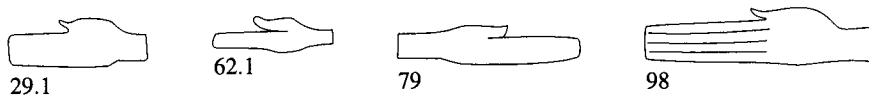

76-81

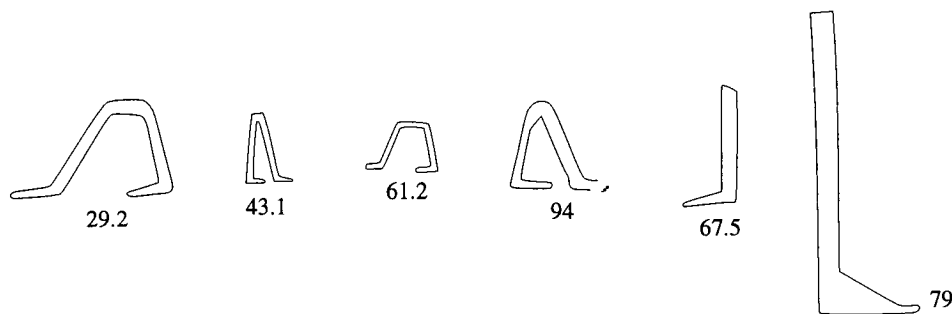

E. Säugetiere

82-85

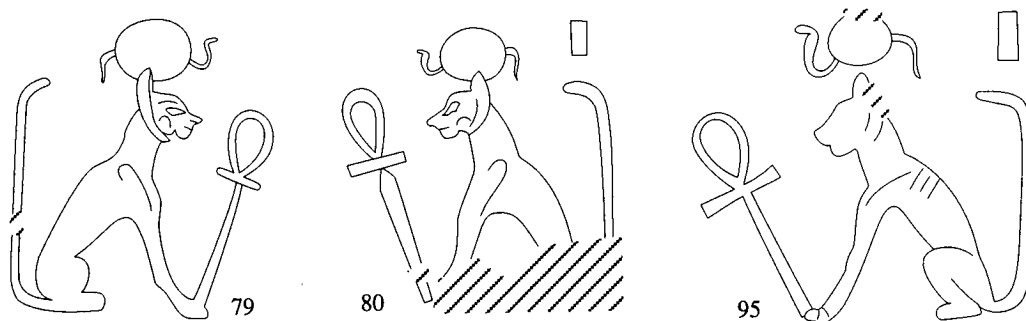

86-89



90-92

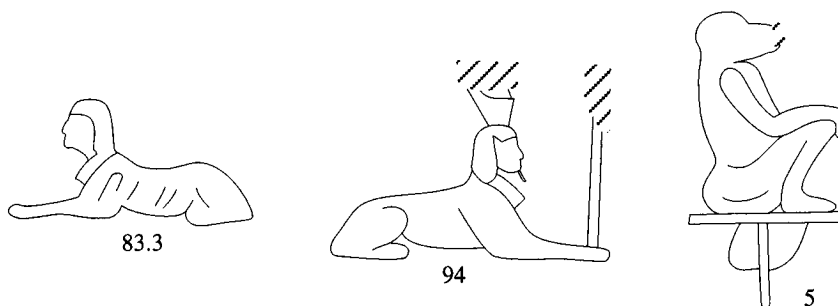

93-95

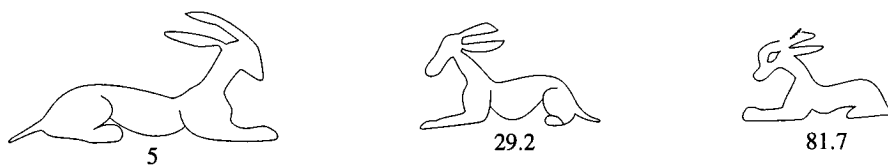

F. Teile von Säugetiere

97-101

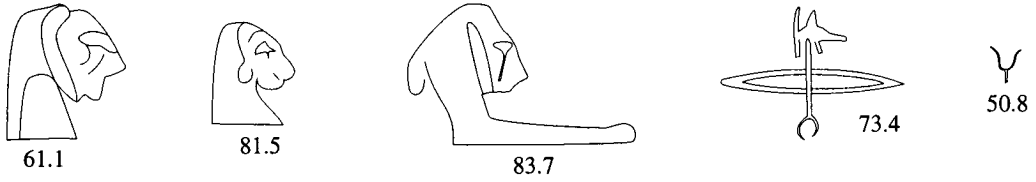

102-105



106-116

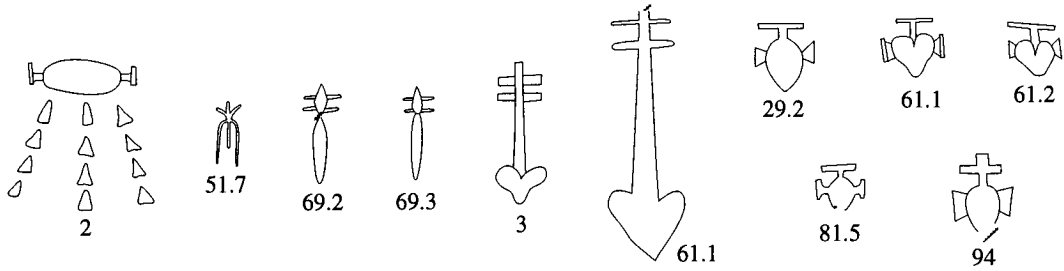

117-127

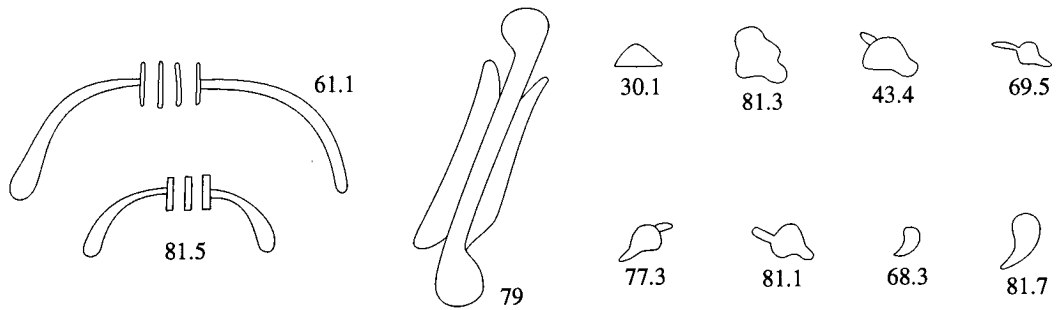

G. Vögel

128-132

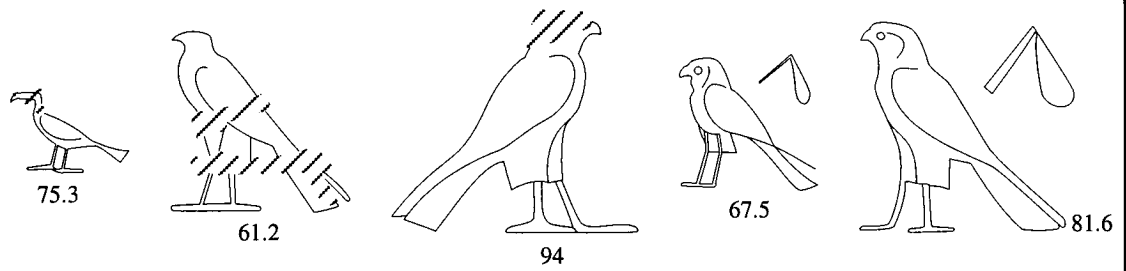

133-135



136-139

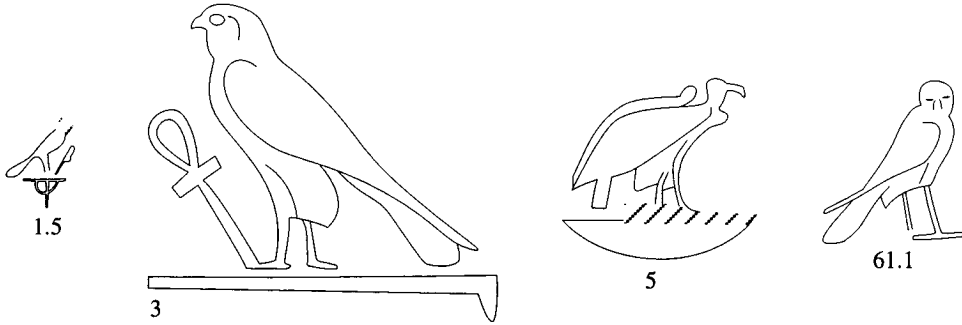

140-143

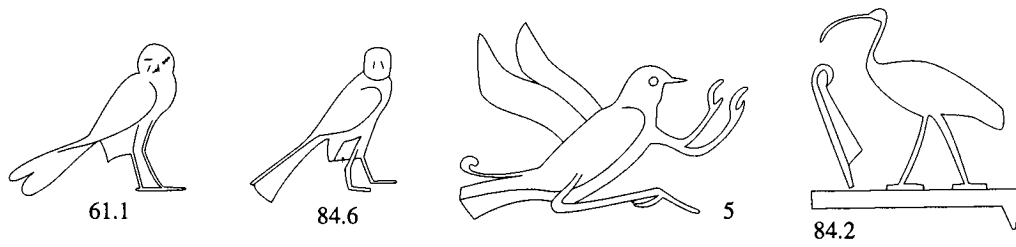

144-147

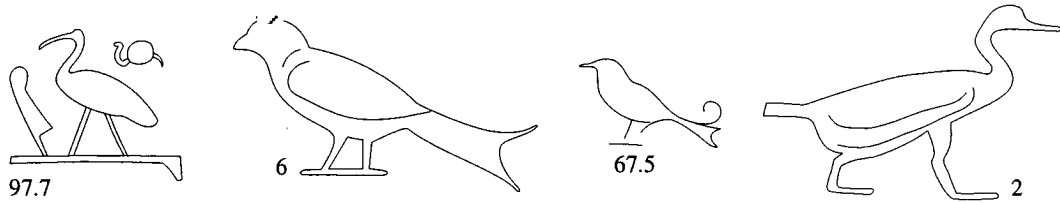

148-150

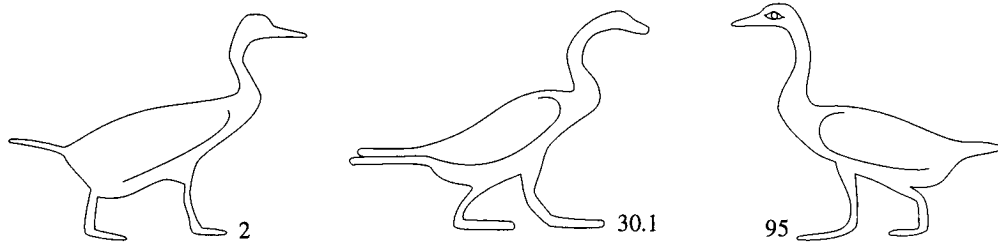

151-156

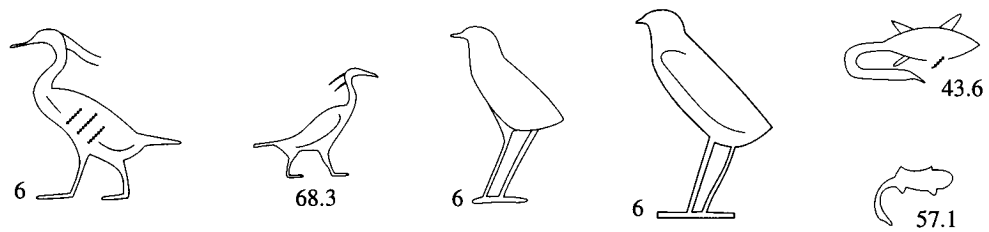

157-159

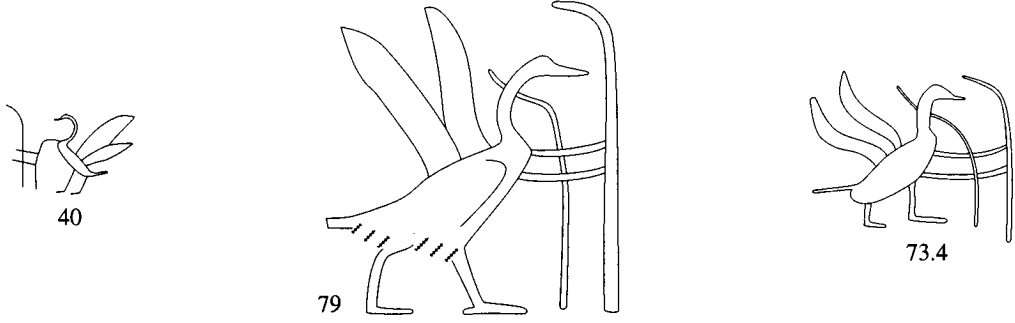

H. Teile von Vögeln

I. Amphibien und Reptilien

160-167

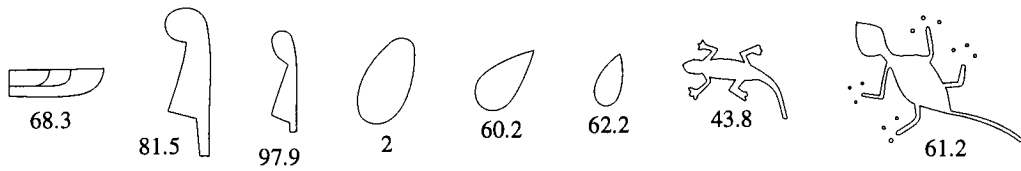

168-170



171-176

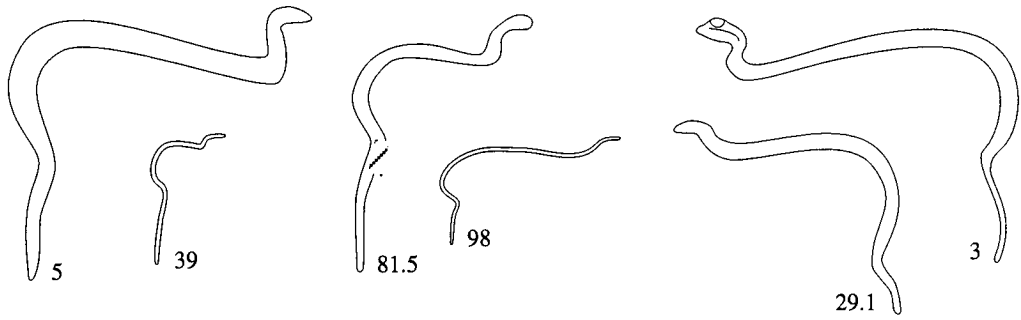

177-181

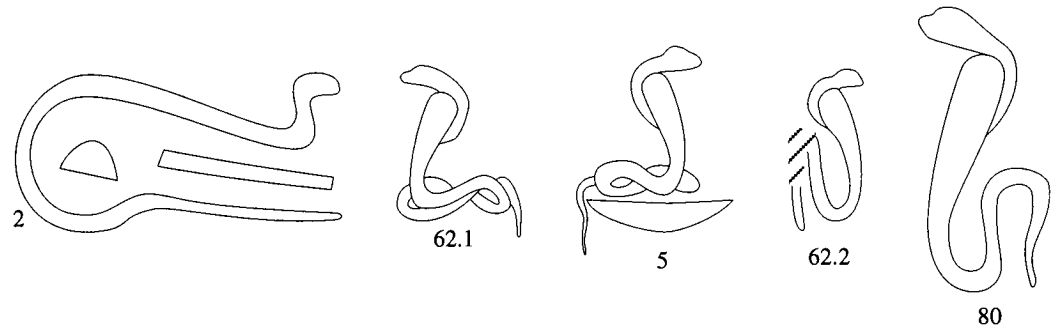

L. Insekten

182-187

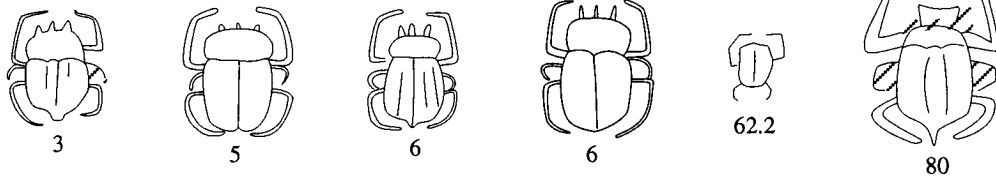

188-190

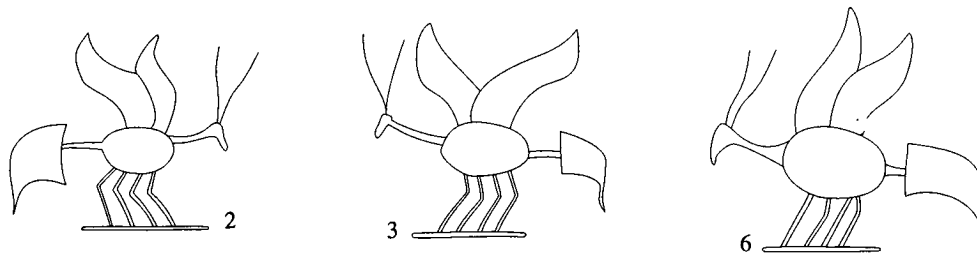

191-193

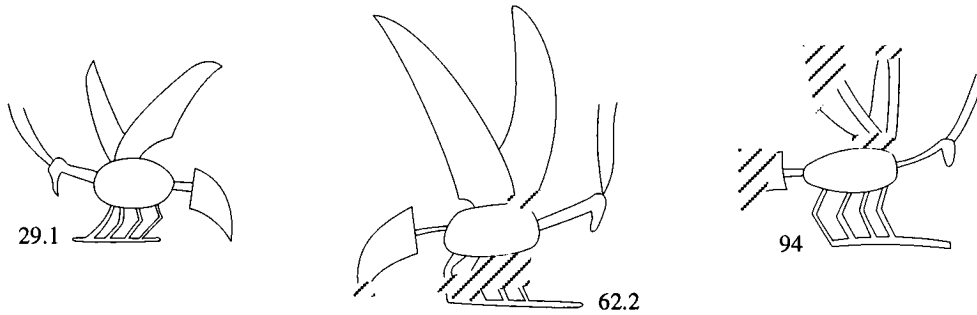

M. Pflanzen

194-200

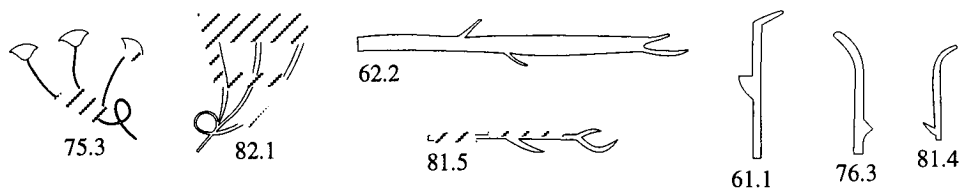

201-206

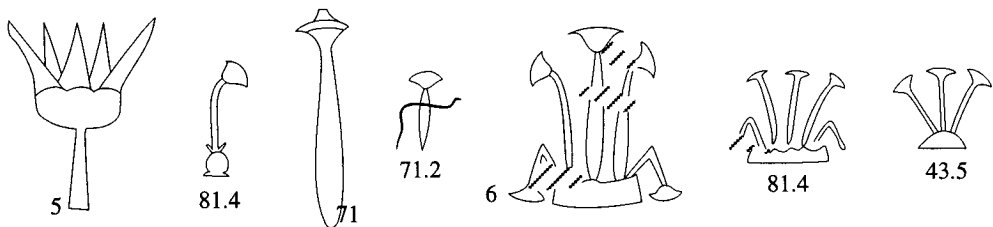

207-215

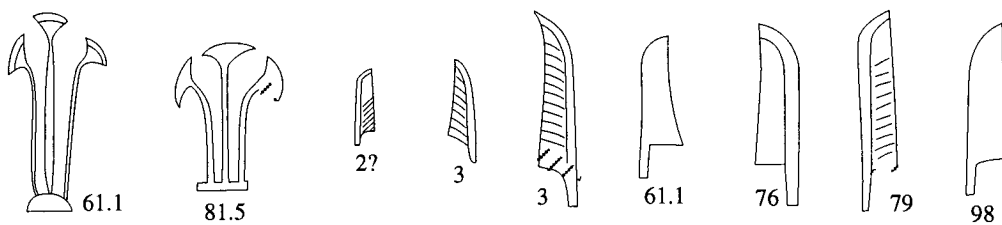

216-222

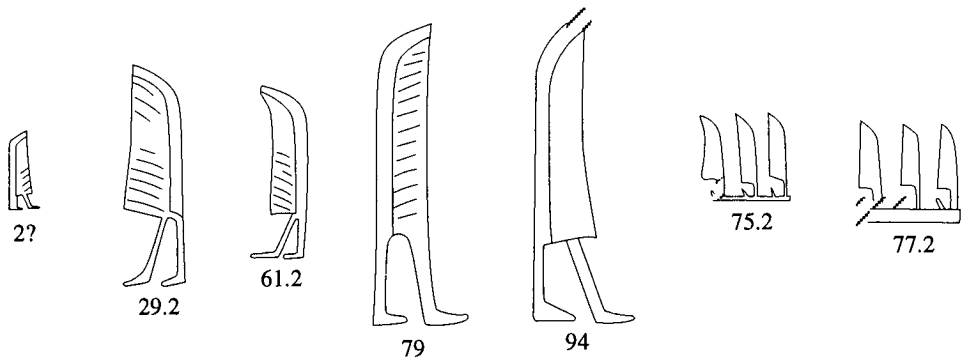

223-230

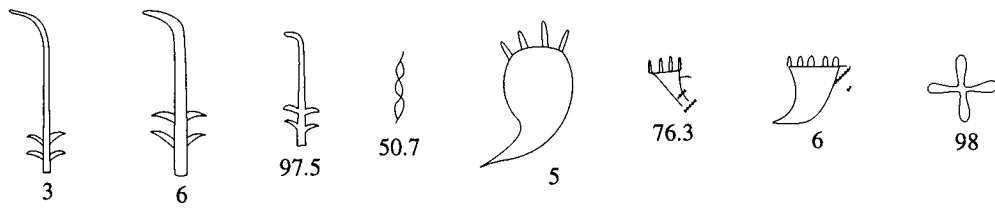

N. Himmel, Erde, Wasser

231-233

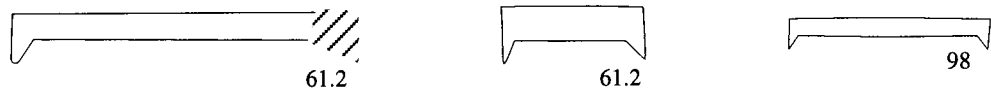

234-238

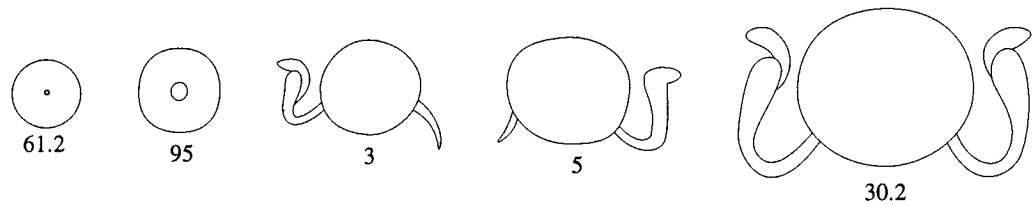

239-241

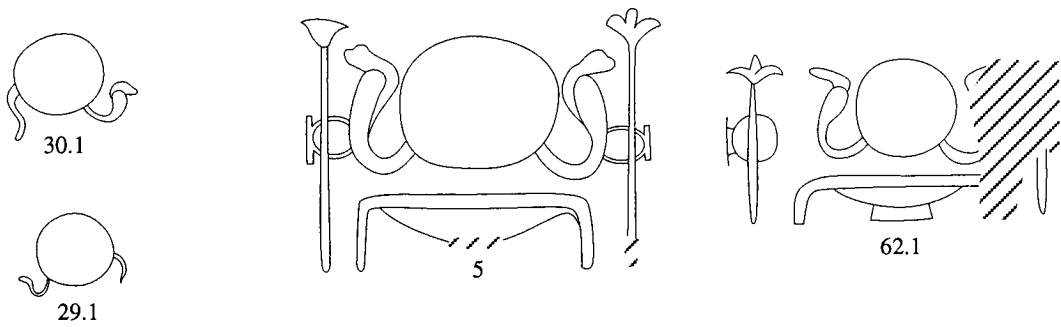

242-245

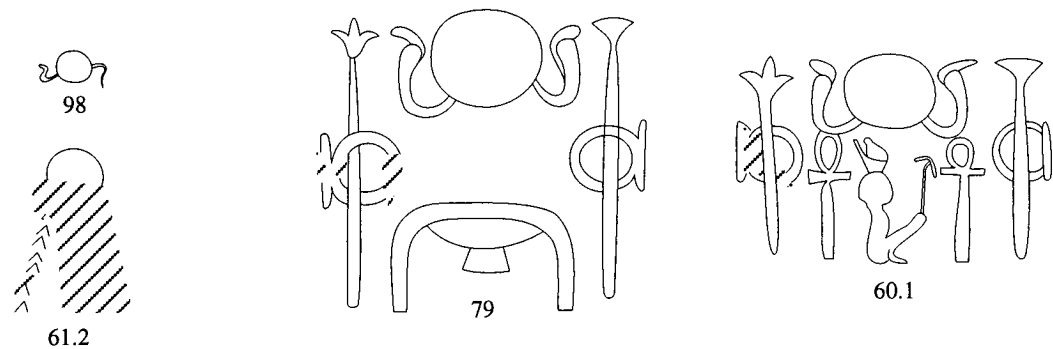

246-251

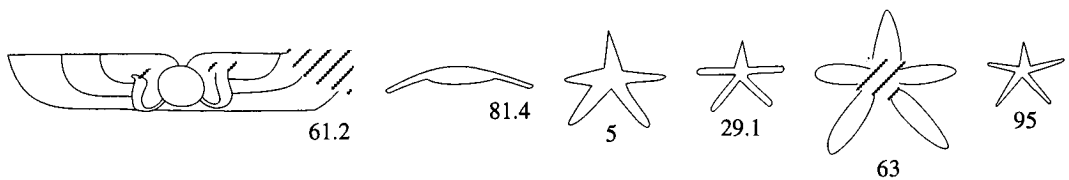

252-255

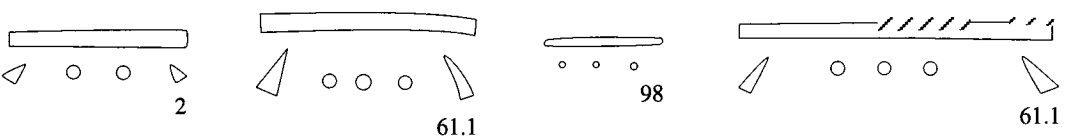

256-258

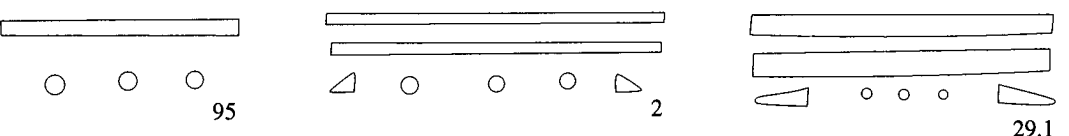

259-265

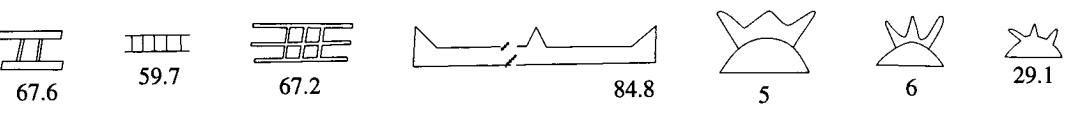

266-276

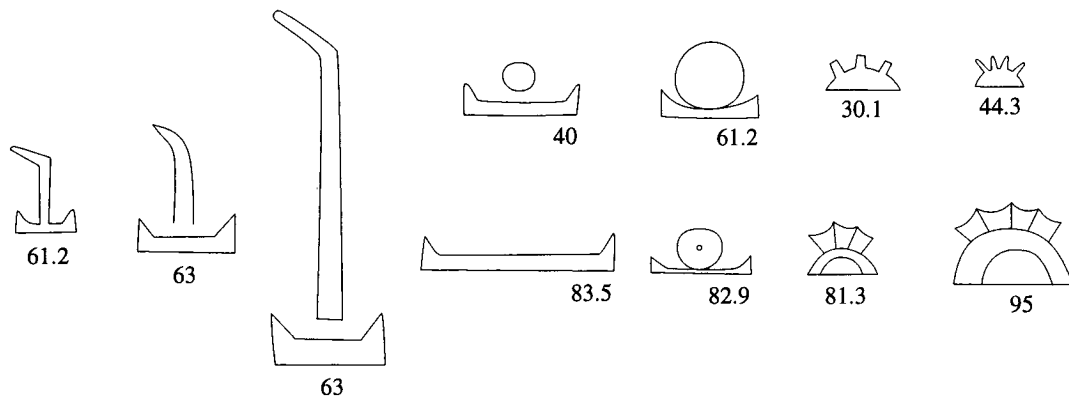

277-282

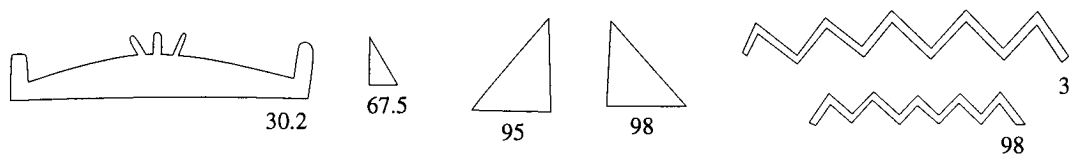

283-286

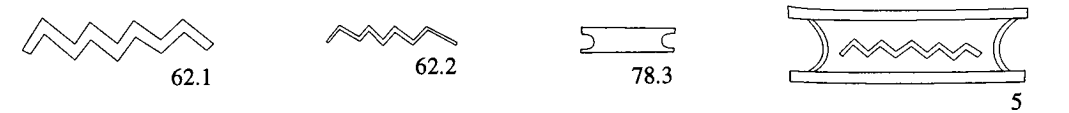

287-290

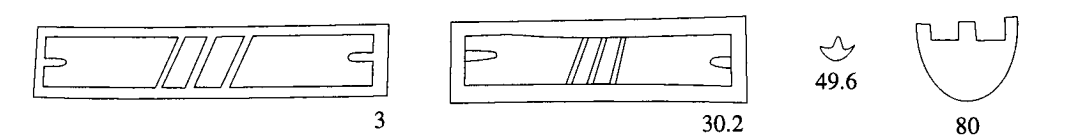

O. Gebäude und ihre Teile

291-297

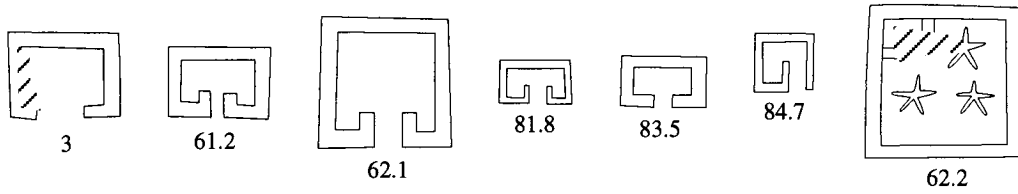

298-301

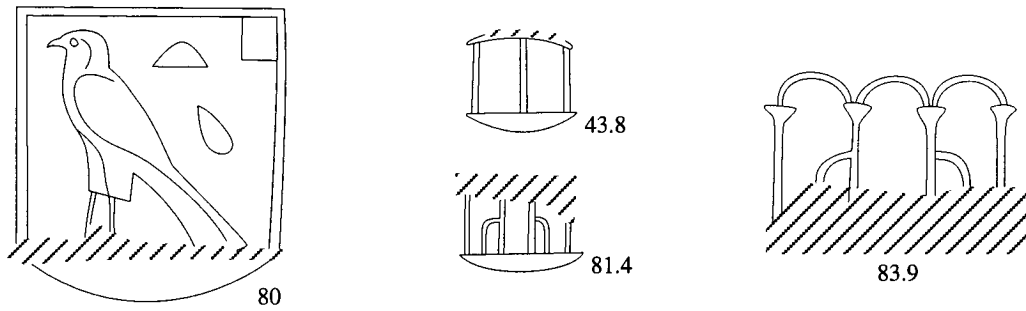

302-312

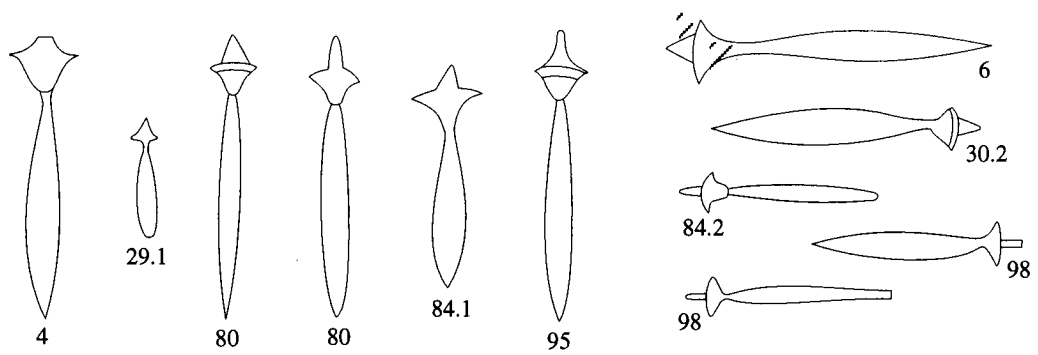

313-316

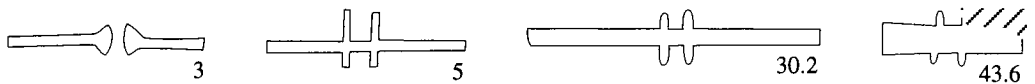

317-320





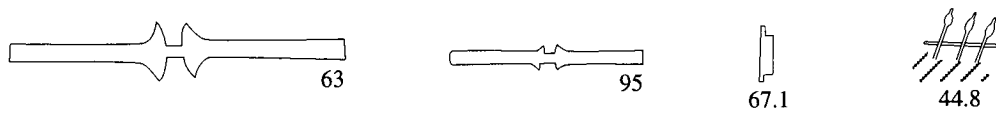



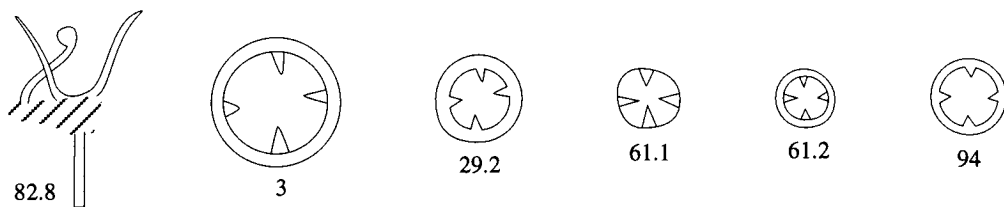



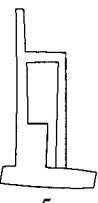
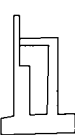
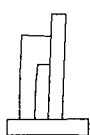
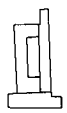
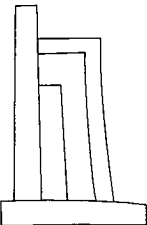
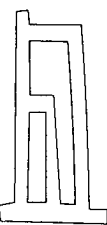

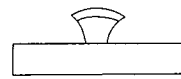

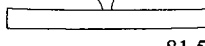
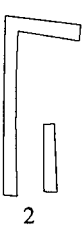

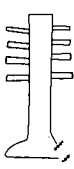



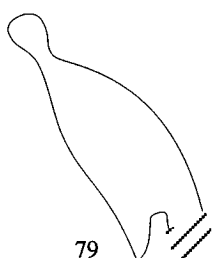
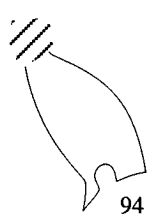

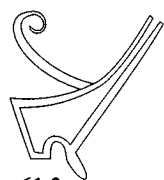
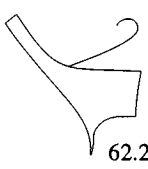
321-324

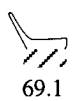

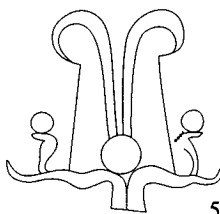
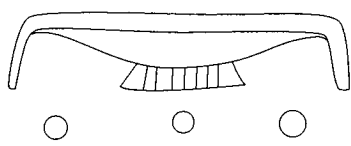
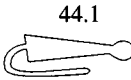
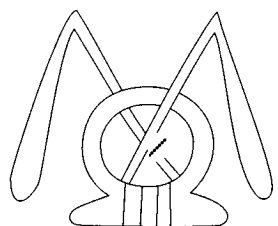
325-330



	P. Schiffe und ihre Teile	Q. Möbel				
331-336	 69.4	 84.7	 5	 98	 61.2	 75.1
				R. Tempelausstattung		
337-344	 94	 79	 2	 61.1	 61.1	 81.1
			 98	 81.5		
				S. Kronen, Kleider, Stäbe		
345-351	 2	 94	 61.1	 81.5	 82.9	 82.9
					 29.2	
352-356	 79	 94	 6	 61.2	 62.2	
357-361	 81.6	 69.1	 81.5	 5	 3	
362-367	 44.1	 81.8	 98	 1.7	 84.8	
	 57.1					

368-374

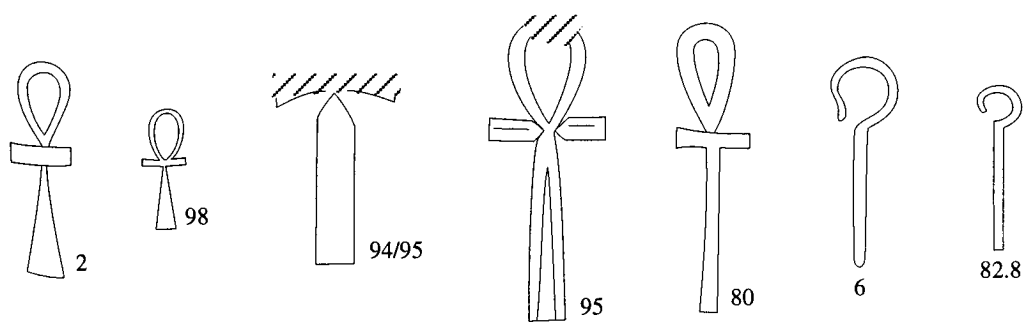

375-380

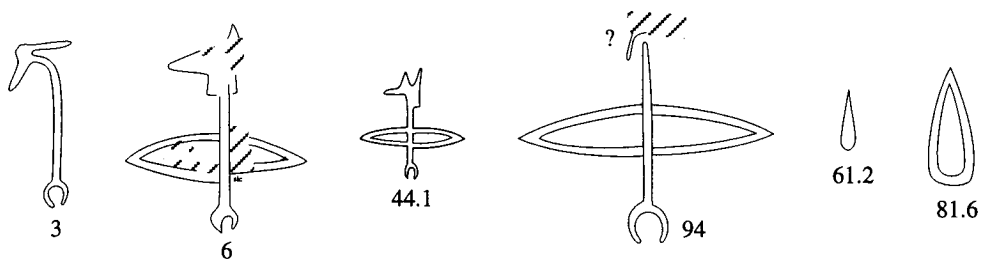

T. Krieg, Jagt, Schlachten

381-384

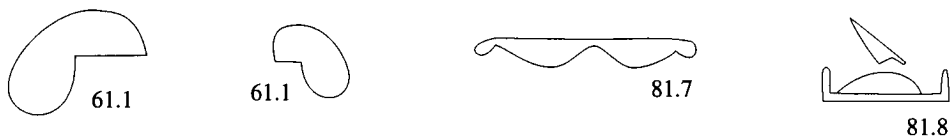

U. Landwirtschaft, Handwerk

385-391

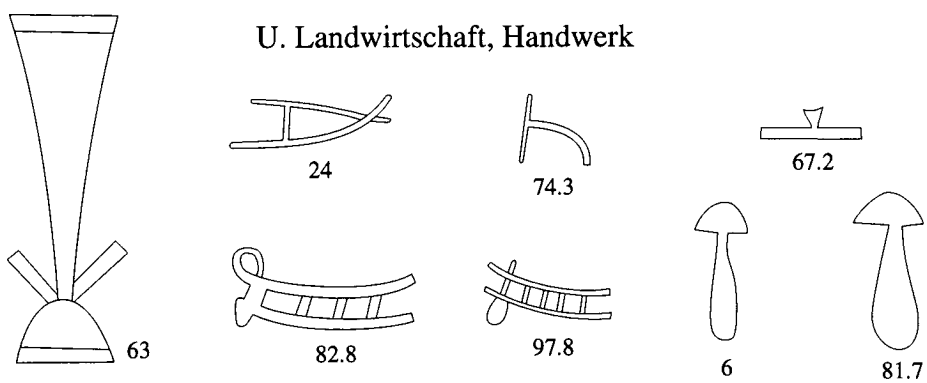

392-397

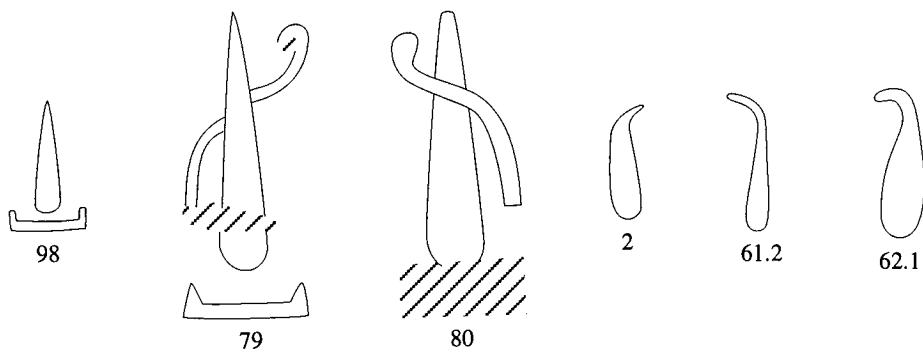

V. Stricke, Körbe, Säcke

398-402

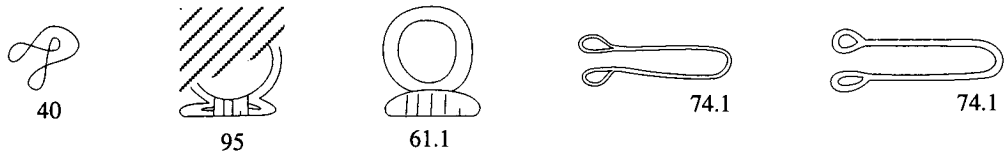

403-412

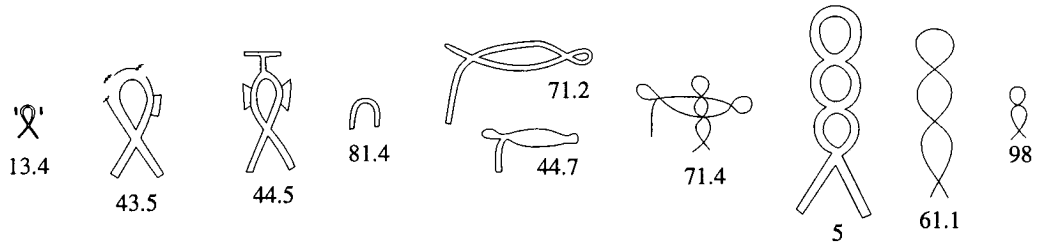

413-415

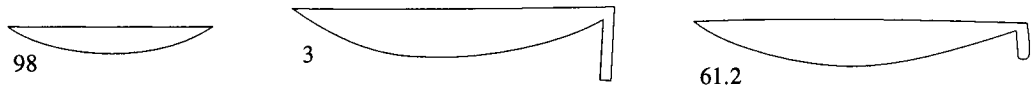

416-419

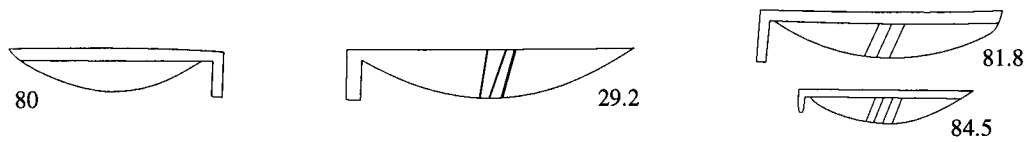

W. Gefäße

420-427

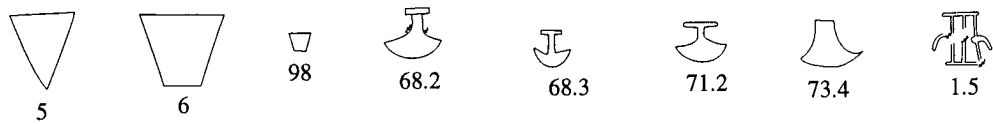

428-435

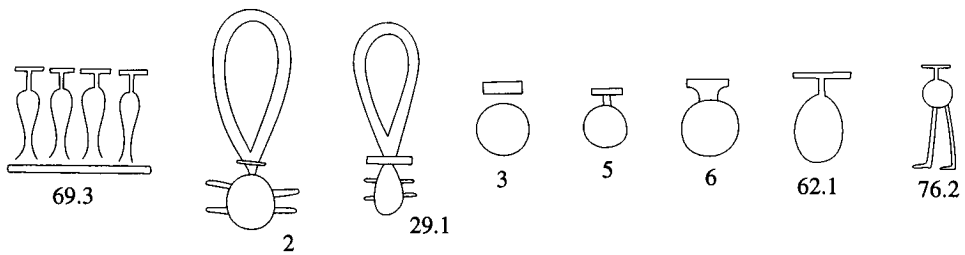

X. Brote und Kuchen

436-446

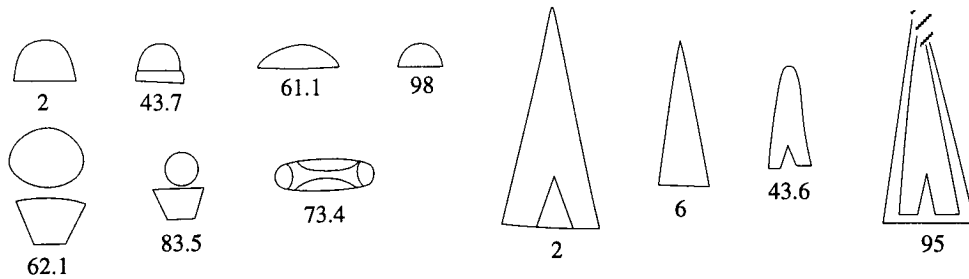

Y. Schrift, Spiele, Musik

447-450

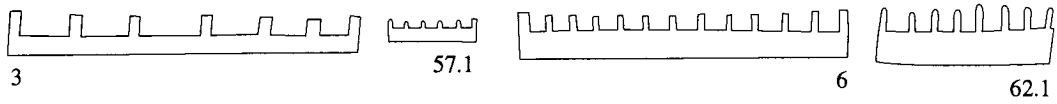

Z. Striche und geometrische Figuren

451-459

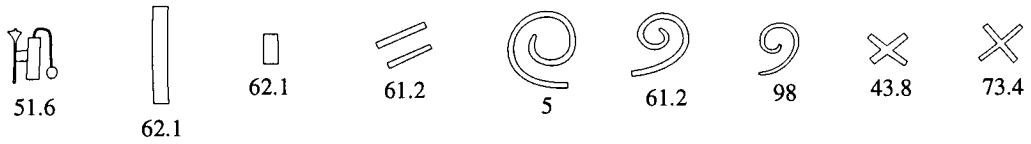

Aa. Unklassifizierbares

460-467

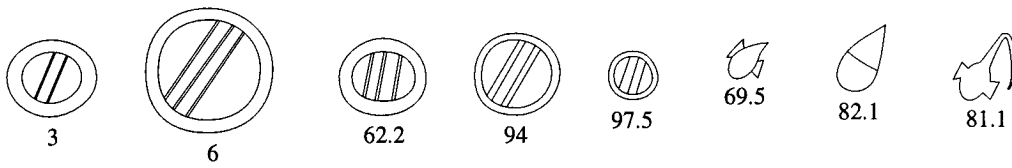

468-473

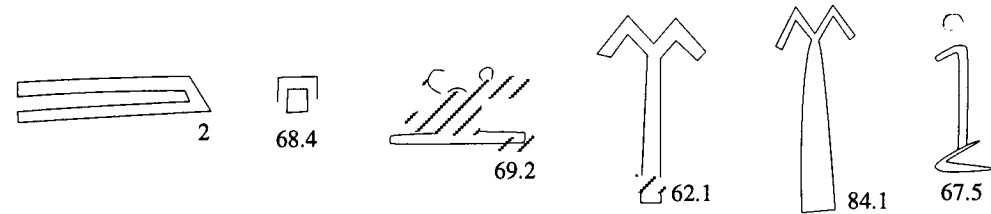

474

50.8