

Monomial bases and PBW filtration in
representation theory

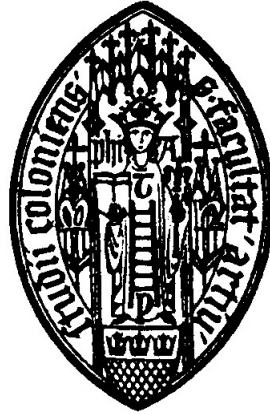

I n a u g u r a l - D i s s e r t a t i o n

zur

Erlangung des Doktorgrades
der Mathematisch-Naturwissenschaftlichen Fakultät
der Universität zu Köln

vorgelegt von

Teodor Backhaus
aus Amsterdam

Köln 2015

Berichterstatter: Prof. Dr. Peter Littelmann

Prof. Dr. Igor Burban

Tag der letzten mündlichen Prüfung: Dienstag, 19. Januar 2016

CONTENTS

| | Page |
|---|------|
| 1. Introduction | 1 |
| 1.1. Overview on the PBW filtration | 2 |
| 1.2. Hilbert–Poincaré polynomials | 5 |
| 1.3. PBW filtration and monomial bases in other types | 5 |
| 1.4. PBW-type filtration and quantum degree cones | 7 |
| 2. The degree of the Hilbert–Poincaré polynomial of PBW-graded modules | 10 |
| 2.1. Introduction | 10 |
| 2.2. Preliminaries | 11 |
| 2.3. Proof of Theorem 1 | 13 |
| References | 15 |
| 3. PBW filtration: Feigin–Fourier–Littelmann modules via Hasse diagrams | 17 |
| 3. Introduction | 17 |
| 3.1. PBW filtration | 19 |
| 3.2. Normal polytopes | 24 |
| 3.3. Spanning property | 28 |
| 3.4. FFL basis of $V(\omega)$ | 33 |
| 3.5. Linear independence | 48 |
| Appendix | 50 |
| References | 53 |
| 4. The PBW filtration and convex polytopes in type B | 55 |
| 4.1. Introduction | 55 |
| 4.2. Preliminaries | 57 |
| 4.3. PBW filtration and graded spaces | 58 |
| 4.4. Dyck path, polytopes and PBW bases | 60 |
| 4.5. Dyck path, polytopes and PBW bases for \mathfrak{so}_7 | 70 |
| 4.6. Construction of favourable modules | 74 |
| 4.7. Appendix | 76 |
| References | 81 |
| 5. Degree cones and monomial bases of Lie algebras and quantum groups | 83 |
| 5.1. General remarks | 83 |
| 5.2. Lie algebras and the classical degree cone | 83 |
| 5.3. Quantum groups and quantum degree cones | 85 |
| 5.4. Examples and properties of quantum degree cones | 89 |
| 5.5. Local and global monomial sets | 93 |
| References | 101 |
| 6. Discussion | 102 |
| 6.1. Hilbert–Poincaré polynomials | 102 |

| | |
|---|-----|
| 6.2. Favourable modules via Hasse diagrams | 103 |
| 6.3. Monomial bases and PBW filtration in type B | 105 |
| 6.4. Degree cones and monomial bases | 106 |
| References | 109 |
| Erklärung zum Eigenanteil | 112 |
| Erklärung zur Dissertation | 113 |
| Lebenslauf | 114 |

ABSTRACT

In this thesis we study the Poincaré–Birkhoff–Witt (PBW) filtration on simple finite-dimensional modules of simple complex finite-dimensional Lie algebras. This filtration is induced by the standard degree filtration on the universal enveloping algebra.

For modules of certain rectangular highest weights we provide a new description of the associated PBW-graded module in terms of generators and relations. We also construct a new basis parametrized by the lattice points of a normal polytope. If the Lie algebra is of type B_3 we construct new bases of PBW-graded modules associated to simple modules of arbitrary highest weight. As an application we find that these modules are favourable modules, implying interesting geometric properties for the degenerate flag varieties. As a side product we state sufficient conditions on convex lattice 0,1-polytopes to be normal.

We study the Hilbert–Poincaré polynomials for the associated PBW-graded modules of simple modules. The computation of their degree can be reduced to modules of fundamental highest weight. We provide these degrees explicitly.

We extend the framework of the PBW filtration to quantum groups and provide case independent constructions, such as giving a filtration on the negative part of the quantum group, such that the associated graded algebra becomes a q -commutative polynomial algebra. By taking the classical limit we obtain, in some cases new, monomial bases and monomial ideals of the associated graded modules.

ZUSAMMENFASSUNG

In dieser Arbeit studieren wir die Poincaré–Birkhoff–Witt (PBW) Filtrierung auf einfachen endlich-dimensionalen Moduln einfacher endlich-dimensionaler komplexer Lie-Algebren. Diese Filtrierung ist durch die standard Gradfiltrierung auf der universell einhüllenden Algebra induziert.

Für bestimmte Höchstgewichtsmoduln geben wir eine neue Beschreibung in Erzeuger und Relationen des assoziierten PBW-graduierten Modulns an. Wir konstruieren ebenfalls eine, durch Gitterpunkte eines Polytopes parametrisierte, Basis an. Für die Lie-Algebra vom Typ B_3 konstruieren wir Basen von PBW-graduierten Moduln assoziiert zu einfachen Moduln von beliebigem höchstem Gewicht. Eine Anwendung unserer Ergebnisse ist, dass diese Moduln *favorisiert* sind, was wiederum interessante geometrische Eigenschaften der assoziierten degenerierten Fahlenvarietäten zur Folge hat. Als Nebenprodukt geben wir hinreichende Bedingungen für konvexe 0,1-Gitterpolytope an, die die Normalität solcher Polytope implizieren.

Wir studieren die Hilbert–Poincaré Polynome der assoziierten PBW-graduierten Moduln einfacher Moduln. Die Berechnung deren Grade kann auf Moduln fundamentaler Gewichte reduziert werden. Wir geben diese Grade explizit an.

Wir erweitern die Theorie der PBW Filtrierung auf Quantengruppen und geben vom Typ unabhängige Konstruktionen an, wie zum Beispiel eine Filtrierung des negativen Teil der Quantengruppe, sodass die assoziierte graduierte Algebra eine q -kommutative Polynomalgebra wird. In dem wir den klassischen Limes betrachten, erhalten wir, in manchen Fällen neue, monomiale Basen und monomiale Ideale des assoziierten graduierten Modulns.

1. INTRODUCTION

In the late 19th century S. Lie introduced Lie algebras as an algebraic tool to study Lie groups. The tangent space at the identity element of a Lie group is naturally endowed with the structure of a Lie algebra. The simple finite-dimensional complex Lie algebras were studied and classified at the end of the 19th century independently by É. Cartan and W. Killing. During the first half of the 20th century, H. Weyl developed fundamental ideas on the representation theory of these simple Lie algebras. Since then various important applications in mathematics and mathematical physics were found so that the theory of simple Lie algebras and their representations evolved to a classical branch of mathematics.

We fix \mathfrak{g} to be a simple finite-dimensional complex Lie algebra and G to be the simple, simply connected algebraic group such that $\text{Lie } G = \mathfrak{g}$. The works of H. Poincaré in 1900, G. Birkhoff and E. Witt in 1937, also independently, led to the famous PBW theorem which provides monomial bases of the universal enveloping algebra $U(\mathfrak{g})$.

We denote by $V(\lambda)$ the simple finite-dimensional module of \mathfrak{g} with dominant integral weight $\lambda \in P^+$.

In 1950, I.M. Gelfand and M.L. Tsetlin provided bases of the highest weight representations for the general linear Lie algebra in [GT50]. This can be used to provide a monomial basis of $V(\lambda)$ in the case of \mathfrak{g} being the special linear Lie algebra. This basis is parametrized by the lattice points of the so called *Gelfand–Tsetlin* (GT) polytope, denoted by $\text{GT}(\lambda) \subset \mathbb{R}_{\geq 0}^N$, where N is the cardinality of the set of positive roots R^+ of \mathfrak{g} . In the other classical types of simple Lie algebras, a basis of $V(\lambda)$ is parametrized by the lattice points of the *generalized Gelfand–Tsetlin* polytope (see [BZ89]).

In 1967, V. G. Kac and R.V. Moody introduced independently *Kac–Moody* algebras. All simple finite-dimensional Lie algebras are Kac–Moody algebras and the theory of infinite-dimensional Lie algebras was established.

The notion of a quantum group appeared first independently in the works of V.G. Drinfeld and M. Jimbo in 1985, using it to construct solutions to the Yang–Baxter equation. Quantum groups are deformations of the universal enveloping algebras of symmetrizable Kac–Moody algebras as Hopf algebras. Powerful tools to study the representations of quantum groups are provided by the theory of *crystal bases* and *canonical bases* developed by M. Kashiwara and G. Lusztig independently (see [Kas90],[Kas91],[Lus90a],[Lus90b]). A different approach is given by the *path model* introduced by P. Littelmann (see [Lit94],[Lit95]). It turned out that Kashiwara’s crystal graph and Littelmann’s graph, defined by the path model, coincide (see [Jos95],[Kas96]).

Using this graph Littelmann introduced the *string* polytope in [Lit98]. Such a polytope parametrizes a basis of the highest weight representation $V(\lambda)$, for an arbitrary simple Lie algebra \mathfrak{g} , by its lattice points. It is denoted by $Q_{\underline{w}_0}(\lambda)$ since it depends on λ and on a reduced expression \underline{w}_0 of the longest element w_0 in the Weyl group W of \mathfrak{g} . The reduced expression determines the cone and the weight determines how to cut the cone by hyperplanes to obtain a polytope. The (generalized) Gelfand–Tsetlin polytope can be recovered as a string polytope for a certain reduced expression. In this case the string polytope is normal which fails to be true in general. Note

that the cone is also described in [BZ01] and studied for example in [BZ93] and [AB04].

1.1. Overview on the PBW filtration. We fix a Cartan subalgebra $\mathfrak{h} \subset \mathfrak{g}$ and consider a triangular decomposition $\mathfrak{g} = \mathfrak{n}^+ \oplus \mathfrak{h} \oplus \mathfrak{n}^-$. We fix a highest weight vector $v_\lambda \in V(\lambda)_\lambda$ and obtain the description $V(\lambda) = U(\mathfrak{n}^-)v_\lambda$. By setting the degree of each non-zero element in $\mathfrak{n}^- \hookrightarrow U(\mathfrak{n}^-)$ to 1, we obtain a \mathbb{N} -filtration of $U(\mathfrak{n}^-)$, for $k \in \mathbb{N}$ we define

$$U(\mathfrak{n}^-)_k = \text{span}\{x_1 x_2 \dots x_l \mid x_i \in \mathfrak{n}^-, l \leq k\},$$

in particular $U(\mathfrak{n}^-)_0 = \mathbb{C}\mathbb{1}$ and for $s \leq t$ we have $U(\mathfrak{n}^-)_s \subseteq U(\mathfrak{n}^-)_t$. The PBW theorem implies that the associated graded algebra is the symmetric algebra: $\text{gr}U(\mathfrak{n}^-) \cong S(\mathfrak{n}^-)$. This increasing filtration induces a \mathbb{N} -filtration on $V(\lambda)$, for $k \in \mathbb{N}$ we define

$$V(\lambda)_k = U(\mathfrak{n}^-)_k v_\lambda,$$

for example $V(\lambda)_0 = \mathbb{C}v_\lambda$. It is called the PBW filtration and has been introduced in [FFJMT]. The associated graded space is \mathbb{N} -graded and defined by

$$V(\lambda)^a = \bigoplus_{s \geq 0} V(\lambda)_s / V(\lambda)_{s-1},$$

where $V(\lambda)_{-1} = \{0\}$. We will refer to $V(\lambda)^a$ as the PBW-graded module. Since $V(\lambda)$ is finite-dimensional so is $V(\lambda)^a$. We fix root vectors $e_\beta \in \mathfrak{n}_\beta^+, f_\beta \in \mathfrak{n}_{-\beta}^-$ for $\beta \in R^+$ and simple roots $\Delta = \{\alpha_1, \alpha_2, \dots, \alpha_n\} \subset R^+$, where n is the rank of \mathfrak{g} . We denote by $\mathfrak{n}^{-,a}$ the vector space \mathfrak{n}^- endowed with the trivial Lie bracket and $\mathfrak{b} = \mathfrak{n}^+ \oplus \mathfrak{h}$. We consider the vector space $\mathfrak{g}^a := \mathfrak{b} \oplus \mathfrak{n}^{-,a}$ and define a Lie bracket $[\cdot, \cdot]^a$ on \mathfrak{g}^a as follows: for \mathfrak{b} and $\mathfrak{n}^{-,a}$ it is defined by their Lie brackets, for $e_\alpha \in \mathfrak{n}^+, f_\beta \in \mathfrak{n}^{-,a}$ we define

$$[e_\alpha, f_\beta]^a = \begin{cases} [e_\alpha, f_\beta], & \text{if } \beta - \alpha \in R^+ \\ 0, & \text{else,} \end{cases}$$

and for $h \in \mathfrak{h}$ we have $[h, f_\beta]^a = [h, f_\beta]$. Note that \mathfrak{g}^a is a degeneration of \mathfrak{g} (see [Fei12]) and in fact a Lie algebra. It turns out that $V(\lambda)^a$ is a \mathfrak{g}^a -module, $\mathfrak{n}^{-,a}$ is acting with operators of degree 1 and \mathfrak{b} is acting with operators of degree 0. This implies that $V(\lambda)^a$ is in general not simple as a \mathfrak{g}^a -module, since $\bigoplus_{s \geq 1} V(\lambda)_s / V(\lambda)_{s-1}$ is a proper submodule if $\dim V(\lambda)^a > 1$.

We have $U(\mathfrak{n}^{-,a}) = S(\mathfrak{n}^-) = \mathbb{C}[f_\beta \mid \beta \in R^+]$ and obtain a cyclic $S(\mathfrak{n}^-)$ -module structure on $V(\lambda)^a$ with generator v_λ^a : $V(\lambda)^a = S(\mathfrak{n}^-)v_\lambda^a$. Let $I(\lambda)$ be the annihilating ideal, i.e. the kernel of the surjective $S(\mathfrak{n}^-)$ -module map $S(\mathfrak{n}^-) \twoheadrightarrow S(\mathfrak{n}^-)v_\lambda^a$, then we have

$$V(\lambda)^a = S(\mathfrak{n}^-)v_\lambda^a \cong S(\mathfrak{n}^-)/I(\lambda).$$

In 2011, E. Feigin, G. Fourier and P. Littelmann in [FFL11a], [FFL11b] (and in [FFL13a] over the integers) were the first to give a monomial basis of $V(\lambda)^a$ and generators of $I(\lambda)$ in the case of the special linear and the symplectic Lie algebra respectively for arbitrary $\lambda \in P^+$. This basis is parametrized by the lattice points of the so called *Feigin–Fourier–Littelmann* (FFL) polytope denoted by $\text{FFL}(\lambda) \subset \mathbb{R}_{\geq 0}^N$. The basis in type A was conjectured by E. Vinberg (see [Vin05]). Note that the FFL polytopes and

the (generalized) GT polytopes are normal polytopes. Monomial bases were also found in type G_2 (see [Gor15a]) using a different approach.

Since the results in type A_n and C_n were known, the framework of the PBW filtration earned a lot of attraction and much progress has been achieved in different branches of representation theory.

In [ABS11] the authors obtain with purely combinatorial methods an explicit bijection between the lattice points of marked chain polytopes and marked order polytopes (see [Sta86]). This implies in particular a bijection between the lattice points $\text{FFL}_{\mathbb{N}}(\lambda) = \text{FFL}(\lambda) \cap \mathbb{N}^N$ of the marked chain polytope $\text{FFL}(\lambda)$ and $\text{GT}_{\mathbb{N}}(\lambda)$, the lattice points of the marked order polytope (generalized) $\text{GT}(\lambda)$. In [Fou16] it is shown that marked order polytopes and marked chain polytopes are not unimodularly equivalent in general and especially the FFL and (generalized) GT polytopes are not unimodularly equivalent in general. Other combinatorial representation theoretical works related to the framework of PBW filtration are [Fou15], where a connection between PBW-graded modules and fusion products is provided, and [K13a], [K13b], where the PBW-graded modules are used to describe models of certain Kirillov–Reshetikhin crystals. In [CF15] and [FM15] the study of the characters of PBW-graded modules has been initiated and motivated the first paper of this thesis.

In the geometric branch of the framework of the PBW filtration, the degenerate flag variety has been studied in a series of papers. Let $B, N^- \subset G$ be the algebraic groups associated to the Lie algebras \mathfrak{b} and \mathfrak{n}^- , B is a Borel and N^- the maximal unipotent subgroup opposite to the Borel. Then there exists a commutative unipotent group with Lie algebra $\mathfrak{n}^{-,a}$, denoted by $N^{-,a} \subset G^a = N^{-,a} \rtimes B$, acting on $V(\lambda)^a$. We emphasize that G^a is the Lie group of \mathfrak{g}^a . The flag variety and the degenerate flag variety respectively are defined by

$$\mathcal{F}(\lambda) = \overline{N^- \cdot \mathbb{C}v_\lambda} \subseteq \mathbb{P}(V(\lambda)), \quad \mathcal{F}_a(\lambda) = \overline{N^{-,a} \cdot \mathbb{C}v_\lambda^a} \subseteq \mathbb{P}(V(\lambda)^a),$$

where $\mathcal{F}(\lambda) \cong G/P_\lambda$ for some parabolic subgroup $P_\lambda \subset G$ stabilizing $\mathbb{C}v_\lambda$. In [Fei12] the degenerate flag variety has been introduced. An explicit realization, in terms of linear algebra, inside a product of Grassmannians has been provided in [Fei11] for type A and in [FFiL14] for type C and other important results have been achieved. For example in loc. cit. for type C and in [FFi13] for type A it is shown that the degenerate flag varieties are normal and Cohen–Macaulay by constructing explicit desingularizations. Other important works on this subject are provided by [Hag14] and [CIFR12] [CIFR13]. In the latter two papers the authors study the degenerate flag varieties in type A by realizing them as quiver Grassmannians.

A beautiful result is obtained in [CIL15], where it is shown that the degenerate flag varieties in type A and C are isomorphic to certain Schubert varieties. The authors use the explicit realization in terms of linear algebra mentioned above. This result also holds in any characteristic (see [CILL]), where the authors use different arguments. They realize the PBW-graded modules as Demazure modules for a Lie algebra of the same type and doubled rank.

We want to recall the definition of a favourable module, note that it can be defined more generally. We choose an ordered basis $\{f_{\beta_1}, f_{\beta_2}, \dots, f_{\beta_N}\}$

of \mathfrak{n}^- and an induced homogeneous lexicographical total order \prec on the monomials in $U(\mathfrak{n}^-)$. We assign to each multi-exponent $\mathbf{t} \in \mathbb{N}^N$ a vector

$$f^{\mathbf{t}}v_\lambda = f_{\beta_1}^{t_1} f_{\beta_2}^{t_2} \cdots f_{\beta_N}^{t_N} v_\lambda \in V(\lambda)$$

and define for $\mathbf{s} \in \mathbb{N}^N$: $F_{\mathbf{s}} = \text{span}\{f^{\mathbf{q}}v_\lambda \mid f^{\mathbf{q}} \preceq f^{\mathbf{s}}\}$ and $F_{\mathbf{s}}^- = \text{span}\{f^{\mathbf{q}}v_\lambda \mid f^{\mathbf{q}} \prec f^{\mathbf{s}}\}$. We have $F_{\mathbf{s}}^- \subset F_{\mathbf{s}}$ and for $\mathbf{p} \prec \mathbf{s}$ we have $F_{\mathbf{p}} \subset F_{\mathbf{s}}$. Note that this defines an increasing \mathbb{N}^N -filtration on $V(\lambda)$ which refines the PBW filtration, since it respects the degree of the monomials. The associated graded space is \mathbb{N}^N -graded:

$$V(\lambda)^t = \bigoplus_{\mathbf{s} \in \mathbb{N}^N} F_{\mathbf{s}}/F_{\mathbf{s}}^-.$$

It turns out that $V(\lambda)^t$ is a cyclic $S(\mathfrak{n}^-)$ -module with generator v_λ^t and the annihilating ideal is monomial. Following Vinberg we denote the set of *essential* multi-exponents by $\text{es}(V(\lambda)) = \{\mathbf{s} \in \mathbb{N}^N \mid f^{\mathbf{s}}v_\lambda^t \neq 0 \text{ in } V(\lambda)^t\}$. Denote the Cartan component in the m -fold tensor product of $V(\lambda)$ by

$$V(\lambda)^{\odot m} = U(\mathfrak{n}^-)(v_\lambda \otimes \cdots \otimes v_\lambda) \subset V(\lambda)^{\otimes m}.$$

A module $V(\lambda)$ is called favourable if

- there exists a normal polytope $P(\lambda) \subset \mathbb{R}_{\geq 0}^N$ such that its lattice points $P_{\mathbb{N}}(\lambda)$ parametrize a basis of $V(\lambda)^a$ and $\text{es}(V(\lambda)) = P_{\mathbb{N}}(\lambda)$,
- the dimension of the Cartan component $V(\lambda)^{\odot m} \subset V(\lambda)^{\otimes m}$ equals $|mP_{\mathbb{N}}(\lambda)|$, where $mP_{\mathbb{N}}(\lambda)$ is the m -fold Minkowski sum of $P_{\mathbb{N}}(\lambda)$.

Since $V(\lambda)^t$ is a $U(\mathfrak{n}^{-,a})$ -module, we define the following projective variety $\mathcal{F}_t(\lambda) = \overline{N^{-,a} \cdot \mathbb{C}v_\lambda} \subseteq \mathbb{P}(V(\lambda)^t)$.

In [FFL13b] the notion of a favourable module is introduced and many interesting properties are stated: if $V(\lambda)$ is favourable, we obtain a monomial basis of $V(\lambda)^{\odot m}$, $(V(\lambda)^{\odot m})^a$ and $(V(\lambda)^{\odot m})^t$ parametrized by the lattice points of the m -fold Minkowski sum of the associated polytope. Further the authors show many interesting properties for the associated projective varieties. The varieties $\mathcal{F}(\lambda)$, $\mathcal{F}_a(\lambda)$ and $\mathcal{F}_t(\lambda)$ are projectively normal and arithmetically Cohen–Macaulay. There exists a flat degeneration of $\mathcal{F}(\lambda)$ into $\mathcal{F}_a(\lambda)$, and for both there exists a flat degeneration into $\mathcal{F}_t(\lambda)$. The variety $\mathcal{F}_t(\lambda)$ is the toric variety defined by the normal polytope $P(\lambda)$. The polytope itself is the Newton–Okounkov body (see [KK12], [HK13]) for the varieties $\mathcal{F}(\lambda)$, $\mathcal{F}_a(\lambda)$ and $\mathcal{F}_t(\lambda)$.

Summarizing: the modules investigated in [FFL11a], [FFL11b], [FFL13a], [Gor15a] and in the second and third paper are favourable. More classes of examples of favourable modules are certain Demazure modules in the \mathfrak{sl}_n -case provided in [Fou14] and [BF]. Recently it was shown that all $V(\lambda)$, $\lambda \in P^+$ are favourable in type D_4 (see [Gor15b]).

This thesis consists of four parts, two published papers, one paper under revision and one preprint which will be submitted soon:

1. *The degree of the Hilbert–Poincaré polynomial of PBW-graded modules.* In collaboration with Lara Bossinger, Christian Desczyk and Ghislain Fourier. *Comptes Rendus Mathématique*, 352 (12): 959 - 963 (2014).

2. *PBW filtration: Feigin–Fourier–Littelmann modules via Hasse diagrams.* In collaboration with Christian Desczyk. *Journal of Lie theory*, 25 (3): 815 - 856 (2015).
3. *The PBW filtration and convex polytopes in type B.* In collaboration with Deniz Kus. Submitted to *Transformation Groups*.
4. *Degree cones and monomial bases of Lie algebras and quantum groups.* In collaboration with Xin Fang and Ghislain Fourier. Preprint.

1.2. Hilbert–Poincaré polynomials. In the first paper we study the PBW-graded modules $V(\lambda)^a$ for arbitrary $\lambda \in P^+$ by studying their Hilbert–Poincaré series. This series is defined by

$$p_\lambda(q) = \sum_{s=0}^{\infty} (\dim V(\lambda)_s / V(\lambda)_{s-1}) q^s.$$

Since $V(\lambda)$ is finite-dimensional, this is in fact a polynomial in q . We compute the maximal $k \in \mathbb{N}$ such that $V(\lambda)_k / V(\lambda)_{k-1}$ is non-zero, often referred to as the PBW-degree.

Recall that w_0 denotes the longest element in the Weyl group of \mathfrak{g} . Every element of $V(\lambda)$ can be described by acting with $U(\mathfrak{n}^+)$ on the lowest weight vector $v_{w_0(\lambda)}$, and $U(\mathfrak{n}^+)V(\lambda)_k \subset V(\lambda)_k$. This implies that $v_{w_0(\lambda)}$ is an element of $V(\lambda)_k$, for the maximal $k \in \mathbb{N}$ such that $V(\lambda)_k / V(\lambda)_{k-1} \neq \{0\}$. Therefore, it suffices to study the one-dimensional weight space $V(\lambda)_{w_0(\lambda)} = \mathbb{C}v_{w_0(\lambda)}$ in order to compute the PBW-degree. We provide the PBW-degree for PBW-graded modules of simple modules for arbitrary simple Lie algebras. It suffices to compute the degree of $p_\lambda(q)$ in the cases where λ is a fundamental weight $\omega_i \in P^+$, $1 \leq i \leq n$. This reduction is provided by [CF15].

Main Theorem 1. (with L. Bossinger, C. Desczyk, G. Fourier) *The degree of $p_{\omega_i}(q)$ is equal to the label of the i -th node in the following diagrams:*

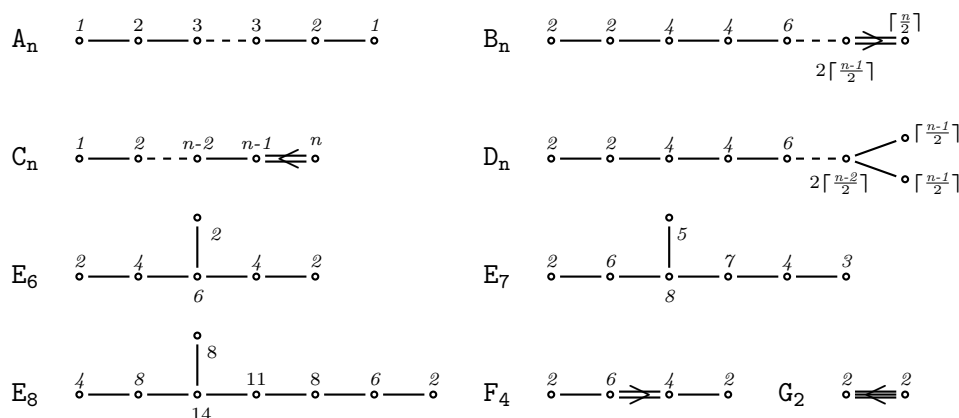

1.3. PBW filtration and monomial bases in other types. In the second and third paper we provide a new monomial basis of $V(\lambda)^a$ parametrized

by the lattice points of a normal polytope and provide generators of the annihilating ideal $I(\lambda)$ in many other types. The polytope is defined by certain paths in the *Hasse* diagram associated to the partial order on R^+ . We refer to these paths as Dyck paths in analogy with the A_n case.

In the second paper our approach is slightly different to the cases of type A and C . Instead of fixing the Lie algebra we fix the type of the highest weight to be a multiple of a fundamental weight, i.e. $\lambda = m\omega_i, m \in \mathbb{N}, 1 \leq i \leq n$. Our main tool is the Hasse diagram and we describe a general procedure which only depends on this diagram. So we reduce the problem of finding a basis of $V(\lambda)^a$ and describing generators of the ideal $I(\lambda)$ to the combinatorics of a (directed) graph.

Let θ be the highest root of \mathfrak{g} , θ^\vee the corresponding coroot. We consider multiples of fundamental weights $\omega_i \in P^+$ such that $\langle \omega_i, \theta^\vee \rangle = 1$. In the case of $\mathfrak{g} = \mathfrak{sp}_{2n}$ we have $\langle \omega_i, \theta^\vee \rangle = 1$ for all $1 \leq i \leq n$, but in these cases, except for ω_1 we do not find a suitable polytope. Nevertheless, as stated before the lattice points of the FFL polytope in type C_n parametrize a basis of $V(\lambda)^a$ for arbitrary $\lambda \in P^+$. Note that the list below includes all minuscule and co-minuscule fundamental weights for arbitrary simple Lie algebras.

Main Theorem 2. (with C. Desczyk) Assume \mathfrak{g} and ω_i appear in the table below: (i) There exists an explicit normal polytope $P(m\omega_i)$ such that its lattice points $P_{\mathbb{N}}(m\omega_i) = P(\lambda) \cap \mathbb{N}^N$ parametrize a basis of $V(m\omega_i)^a$. (ii) The ideal $I(m\omega_i)$ is generated by $U(\mathfrak{n}^+) \circ \text{span}\{f_\beta^{\langle m\omega_i, \beta^\vee \rangle + 1} \mid \beta \in R^+\}$, where $V(m\omega_i)^a \cong S(\mathfrak{n}^-)/I(m\omega_i)$.

| Type of \mathfrak{g} | weight ω | Type of \mathfrak{g} | weight ω |
|------------------------|------------------------------------|------------------------|----------------------|
| A_n | $\omega_k, 1 \leq k \leq n$ | E_6 | ω_1, ω_6 |
| B_n | ω_1, ω_n | E_7 | ω_7 |
| C_n | ω_1 | F_4 | ω_4 |
| D_n | $\omega_1, \omega_{n-1}, \omega_n$ | G_2 | ω_1 |

In the third paper we investigate the special odd orthogonal Lie algebra and find similar results as above for multiples of the adjoint representation and for some other interesting cases. In order to describe the polytopes we introduce the notion of a double Dyck path, which is the union of two usual Dyck paths with a certain extra condition. In the case of the Lie algebra \mathfrak{so}_7 we find a polytope, whose lattice points parametrize a basis of $V(\lambda)^a$ for arbitrary dominant integral weights $\lambda \in P^+$. We also state in the appendix generators of the annihilating ideal $I(\lambda)$ of the PBW-graded module in the case of G_2 .

Main Theorem 3. (with Kus) (i) If \mathfrak{g} is of type B_n and $\lambda = m\omega_2$ or $\lambda = 2m\omega_3, m \in \mathbb{N}$, then there exists an explicit normal polytope $P(\lambda)$ such that its lattice points $P_{\mathbb{N}}(\lambda)$ parametrize a basis of $V(\lambda)^a$. (ii) The ideal $I(\lambda)$ is generated by $U(\mathfrak{n}^+) \circ \text{span}\{f_\beta^{\langle \lambda, \beta^\vee \rangle + 1} \mid \beta \in R^+\}$, where $V(\lambda)^a \cong S(\mathfrak{n}^-)/I(\lambda)$. (iii) If \mathfrak{g} is of type B_3 and $\lambda \in P^+$, then there exists an explicit normal polytope $P(\lambda)$ such that its lattice points $P_{\mathbb{N}}(\lambda)$ parametrize a basis of $V(\lambda)^a$.

Further for $\lambda, \mu \in P^+$ we have $P_{\mathbb{N}}(\lambda) + P_{\mathbb{N}}(\mu) = P_{\mathbb{N}}(\lambda + \mu)$. Here $+$ denotes the Minkowski sum on the left-hand side.

The normality in the second paper follows from a general result about 0, 1-polytopes, where we adapt the idea of the proof of the Minkowski sum property of the FFL polytopes in the A_n case. In the third paper we prove the Minkowski sum property by direct computations. As stated above, the modules in Theorem 2 and in Theorem 3 are favourable.

A natural question is whether in type A_n and $\lambda = m\omega_i \in P^+$ the FFL basis of $V(\lambda)^a$ described by the lattice points of the polytope $\text{FFL}(\lambda)$ and the basis of $V(\lambda)^a$ described by $P_{\mathbb{N}}(\lambda)$ in the second paper are the same. We consider the fundamental weight ω_i and assume $2 \leq i \leq n - 1$ and $n \geq 3$. We have

$$f_{\alpha_{i-1}+\alpha_i+\alpha_{i+1}} f_{\alpha_i} v_{\omega_i}^a \neq 0 \text{ and } f_{\alpha_{i-1}+\alpha_i} f_{\alpha_i+\alpha_{i+1}} v_{\omega_i}^a \neq 0 \text{ in } V(\omega_i)^a.$$

We have $\dim V(\omega_i)_{\omega_i - \alpha_{i-1} - 2\alpha_i - \alpha_{i+1}} = 1$. This implies to obtain a basis of $V(\omega_i)^a$ we need to pick exactly one of those elements. The first is an element of the FFL basis, the second is an element of the basis described in the second paper. In this sense the FFL basis, and the basis described in the second paper are in general two different bases of $V(\lambda)^a$.

Nevertheless, the describing polytopes $\text{FFL}(\lambda)$ and $P(\lambda)$ (in type A_n) are unimodularly equivalent and hence the projective toric varieties defined by the normal polytopes are isomorphic. In contrast, in general they are not isomorphic to the toric varieties constructed in [AB04] corresponding to Gelfand–Tsetlin polytopes (see also [GL97] and [KM05]), since the FFL and GT polytopes are not unimodularly equivalent in general as stated above.

Note that the example above also shows that $I(\lambda)$ is not a monomial ideal in general, since for some non-zero constant $c \in \mathbb{C}$ we have:

$$c f_{\alpha_{i-1}+\alpha_i+\alpha_{i+1}} f_{\alpha_i} - f_{\alpha_{i-1}+\alpha_i} f_{\alpha_i+\alpha_{i+1}} \in I(\omega_i).$$

1.4. PBW-type filtration and quantum degree cones. Recently in [FFR15] the authors extended the framework of the PBW filtration to quantum groups of type A_n . They provide a degree on the quantum PBW root vectors arising from the Hall algebra of quiver representations, and define a \mathbb{N} -filtration \mathcal{F} on the negative part of the quantum group $U_q(\mathfrak{n}^-)$ such that associated graded algebra becomes a q -commutative polynomial algebra:

$$gr_{\mathcal{F}} U_q(\mathfrak{n}^-) \cong S_q(\mathfrak{n}^-).$$

This fails already in small examples, if one simply attaches to each quantum PBW root vector the degree 1, as in the definition (see Subsection 1.1) of the PBW filtration for simple Lie algebras. Denote by $V_q(\lambda)$ the simple finite-dimensional module (of type 1) of $U_q(\mathfrak{g})$ of highest weight $\lambda \in P^+$. The associated graded $S_q(\mathfrak{n}^-)$ -module is denoted by $V_q^{\mathcal{F}}(\lambda)$ with annihilating ideal $I_q^{\mathcal{F}}(\lambda) \subset S_q(\mathfrak{n}^-)$. As an important application the authors obtain a monomial basis of $V_q^{\mathcal{F}}(\lambda)$ parametrized by the lattice points of the polytope $\text{FFL}(\lambda)$ and the ideal $I_q^{\mathcal{F}}(\lambda)$ is monomial. By taking the classical limit $q \rightarrow 1$ they obtain a \mathbb{N} -filtration on $V(\lambda)$ such that the annihilating Ideal $I^{\mathcal{F}}(\lambda) \subset S(\mathfrak{n}^-)$ of the associated graded module $V^{\mathcal{F}}(\lambda)$ is a monomial ideal. As stated before this is not true in the classic setup of the PBW filtration.

In the fourth paper we study the negative part of the quantum group associated to a arbitrary simple Lie algebra with a different approach. We define a set $\mathcal{D}_{\underline{w}_0}^q \subset \mathbb{R}_+^N$ depending on the Lie algebra \mathfrak{g} and on a reduced expression \underline{w}_0 , where each lattice point in this set induces a \mathbb{N} -filtration on $U_q(\mathfrak{n}^-)$ such that the associated graded algebra becomes a q -commutative polynomial algebra. Since it is closed under summation and non-zero scalar multiplication we call $\mathcal{D}_{\underline{w}_0}^q$ the *quantum degree cone*. We show that $\mathcal{D}_{\underline{w}_0}^q$ is not empty for arbitrary simple Lie algebras and arbitrary reduced expression.

We fix a simple Lie algebra \mathfrak{g} , the quantum group $U_q(\mathfrak{g})$ associated to \mathfrak{g} with generic parameter q and a reduced expression \underline{w}_0 of the longest Weyl group element $w_0 \in W$. The reduced expression induces a convex total order $\beta_1 < \beta_2 < \dots < \beta_N$ on the positive roots of \mathfrak{g} , i.e for all $\beta_i, \beta_j, \beta_k \in R^+$:

$$\beta_i + \beta_j = \beta_k \implies i < k < j \text{ or } j < k < i.$$

The PBW basis theorem for quantum groups (see [Lus10]) provides a $\mathbb{C}(q)$ -basis of $U_q(\mathfrak{n}^-)$, namely

$$\{F^{\mathbf{c}} = F_{\beta_1}^{c_1} F_{\beta_2}^{c_2} \dots F_{\beta_N}^{c_N} \mid \mathbf{c} = (c_1, c_2, \dots, c_N) \in \mathbb{N}^N\}.$$

The commutation relations between these quantum PBW root vectors is given by the Levendorskiĭ–Soibelman (L–S) formula ([LS91]) for any $i < j$,

$$F_{\beta_j} F_{\beta_i} - q^{-(\beta_i, \beta_j)} F_{\beta_i} F_{\beta_j} = \sum_{n_{i+1}, \dots, n_{j-1} \geq 0} p(n_{i+1}, \dots, n_{j-1}) F_{\beta_{i+1}}^{n_{i+1}} \dots F_{\beta_{j-1}}^{n_{j-1}}, \quad (1)$$

where $p(n_{i+1}, \dots, n_{j-1}) \in \mathbb{C}[q^{\pm 1}]$. We denote

$$M_{i,j} = \{F_{\beta_{i+1}}^{n_{i+1}} F_{\beta_{i+2}}^{n_{i+2}} \dots F_{\beta_{j-1}}^{n_{j-1}} \mid n_{i+1}\beta_{i+1} + n_{i+2}\beta_{i+2} + \dots + n_{j-1}\beta_{j-1} = \beta_i + \beta_j\},$$

then for weight reasons, the sum in the right-hand side of the L–S formula is supported in $M_{i,j}$. We define the *quantum degree cone* $\mathcal{D}_{\underline{w}_0}^q$ by:

$$\mathcal{D}_{\underline{w}_0}^q = \{\mathbf{d} \in \mathbb{R}_{\geq 0}^N \mid i < j: d_i + d_j > \sum_{k=i+1}^{j-1} n_k d_k \text{ if } p(n_{i+1}, \dots, n_{j-1}) \neq 0 \text{ in (1)}\}.$$

Main Theorem 4. (with X. Fang, G. Fourier) (i) For any reduced expression \underline{w}_0 of w_0 , the set $\mathcal{D}_{\underline{w}_0}^q$ is non-empty.

(ii) Let \mathfrak{g} be a simple Lie algebra of rank $n \geq 3$. Then

$$\bigcap_{\underline{w}_0 \in R(w_0)} \mathcal{D}_{\underline{w}_0}^q = \emptyset,$$

where $R(w_0) = \{\underline{w}_0 \mid \underline{w}_0 \text{ reduced expression of } w_0\}$.

Note if \mathfrak{g} is of rank $n \leq 2$ there are two reduced expression of w_0 and both induce the same cone. We describe the cone explicitly.

Since $\mathcal{D}_{\underline{w}_0}^q$ is not empty we can choose a $\mathbf{d} \in \mathcal{D}_{\underline{w}_0}^q$ and define a filtration on $U_q(\mathfrak{n}^-)$, for $k \in \mathbb{N}$ we define

$$\mathcal{F}_k^{\mathbf{d}} = \text{span}\{F^{\mathbf{t}} \in U_q(\mathfrak{n}^-) \mid t_1 d_1 + t_2 d_2 + \dots + t_N d_N \leq k\}.$$

The L–S formula ensures that this defines a filtration on $U_q(\mathfrak{n}^-)$ and that the associated graded algebra $\text{gr}^{\mathbf{d}} U_q(\mathfrak{n}^-)$ is a q -commutative polynomial algebra

isomorphic to $S_q(\mathfrak{n}^-)$. We obtain a filtration on $V_q(\lambda)$ by setting

$$\mathcal{F}_k^{\mathbf{d}}V_q(\lambda) = \mathcal{F}_k^{\mathbf{d}}\mathbf{v}_\lambda,$$

where \mathbf{v}_λ is a cyclic generator of $V_q(\lambda)$. The associated graded module is denoted by $V_q^{\mathbf{d}}(\lambda)$ and is a cyclic $S_q(\mathfrak{n}^-)$ -module with cyclic generator denoted by $\mathbf{v}_\lambda^{\mathbf{d}}$: $V_q^{\mathbf{d}}(\lambda) = S_q(\mathfrak{n}^-)\mathbf{v}_\lambda^{\mathbf{d}}$. The annihilating ideal is denoted by $I_q^{\mathbf{d}}(\lambda)$.

By taking the classical limit $q \rightarrow 1$ we obtain several applications. For example we describe new monomial ideals and monomial bases of $V^{\mathbf{d}}(\lambda)$, $\lambda \in P^+$ with the known polytopes in the cases $\mathbf{A}_n, \mathbf{B}_3, \mathbf{D}_4, \mathbf{G}_2$ and conjecturally in \mathbf{C}_n . We also state whether the lattice points of these polytopes parametrize a monomial basis for $V_q^{\mathbf{d}}(\lambda)$.

Acknowledgments. First of all, I would like to thank my supervisor Peter Littelmann for his guidance, his support and for the opportunity to write this thesis. Special thanks go to Ghislain Fourier for uncountable discussions, good advices and hints. Special thanks also go to Christian Desczyk and Deniz Kus, not only for intensive collaboration, but also for becoming good friends. Many thanks to my other co-authors Lara Bossinger and Xin Fang for giving me very good remarks on my thesis. I would like to thank the whole working group in Cologne, my family and my friends for always supporting me. I would like to thank Anne Schilling and the University of California, Davis for their hospitality during my stay there in the beginning of 2015. I would like to thank Evgeny Feigin for answering a lot of questions via e-mail. Last but not least, I would like to thank Annette Wellhausen and Matt O'Dell for grammar corrections and my girlfriend Julia Beer for having my back.

I was funded by the DFG priority program SPP 1388 'Representation Theory'.

2. THE DEGREE OF THE HILBERT–POINCARÉ POLYNOMIAL OF PBW-GRADED MODULES

TEODOR BACKHAUS AND LARA BOSSINGER AND CHRISTIAN DESCZYK AND
GHISLAIN FOURIER

ABSTRACT. In this note, we study the Hilbert-Poincaré polynomials for the associated PBW-graded modules of simple modules for a simple complex Lie algebra. The computation of their degree can be reduced to modules of fundamental highest weight. We provide these degrees explicitly.

Nous étudions les polynômes de Hilbert-Poincaré pour les modules PBW-gradués associés aux modules simples d'une algèbre de Lie simple complexe. Le calcul de leur degré peut être restreint aux modules de plus haut poids fondamental. Nous donnons une formule explicite pour ces degrés.

1. INTRODUCTION

Let \mathfrak{g} be a simple complex finite-dimensional Lie algebra with triangular decomposition $\mathfrak{g} = \mathfrak{n}^+ \oplus \mathfrak{h} \oplus \mathfrak{n}^-$. Then the PBW filtration on $U(\mathfrak{n}^-)$ is given as $U(\mathfrak{n}^-)_s := \text{span}\{x_{i_1} \cdots x_{i_l} \mid x_{i_j} \in \mathfrak{n}^-, l \leq s\}$. The associated graded algebra is isomorphic to $S(\mathfrak{n}^-)$. Let $V(\lambda)$ be a simple finite-dimensional module of highest weight λ and v_λ a highest weight vector. Then we have an induced filtration on $V(\lambda) = U(\mathfrak{n}^-)v_\lambda$, denoted $V(\lambda)_s := U(\mathfrak{n}^-)_s v_\lambda$. The associated graded module $V(\lambda)^a$ is a $S(\mathfrak{n}^-)$ -module generated by v_λ .

These modules have been studied in a series of papers. Monomial bases of the graded modules and the annihilating ideals have been provided for the $\mathfrak{sl}_n, \mathfrak{sp}_n$ [FFL11a, FFL11b, FFL13b], for cominuscule weights and their multiples in other types [BD14], for certain Demazure modules in the \mathfrak{sl}_n -case in [Fou14b, BF14]. In type G_2 there is a monomial basis provided by [Gor11].

The degenerations of the corresponding flag varieties have been studied in [Fei12, FFL13a, CIL14, CILL14]. Further, it turned out ([Fou14a]), that these PBW degenerations have an interesting connection to fusion product for current algebras. The study of the characters of PBW-graded modules has been initiated in [CF13, FM14].

In the present paper we will compute the maximal degree of PBW-graded modules in full generality (for all simple complex Lie algebras), where there have been partial answers in the above series of paper for certain cases.

We denote the Hilbert-Poincaré series of the PBW-graded module, often referred to as the *q-dimension of the module*, by

$$p_\lambda(q) = \sum_{s=0}^{\infty} (\dim V(\lambda)_s / V(\lambda)_{s-1}) q^s.$$

Since $V(\lambda)$ is finite-dimensional, this is obviously a polynomial in q . In this note we want to study further properties of this polynomial. We see immediately that the constant term of $p_\lambda(q)$ is always 1 and the linear term is equal to

$$\dim(\mathfrak{n}^-) - \dim \text{Ker}(\mathfrak{n}^- \longrightarrow \text{End}(V(\lambda))).$$

Our main goal is to compute the degree of $p_\lambda(q)$ and the first step is the following reduction [CF13, Theorem 5.3 ii]):

Theorem. Let $\lambda_1, \dots, \lambda_s \in P^+$ and set $\lambda = \lambda_1 + \dots + \lambda_s$. Then

$$\deg p_\lambda(q) = \deg p_{\lambda_1}(q) + \dots + \deg p_{\lambda_s}(q).$$

It remains to compute the degree of $p_\lambda(q)$ where λ is a fundamental weight. We have done this for all fundamental weights of simple complex finite-dimensional Lie algebras:

Theorem 1. The degree of $p_{\omega_i}(q)$ is equal to the label of the i -th node in the following diagrams:

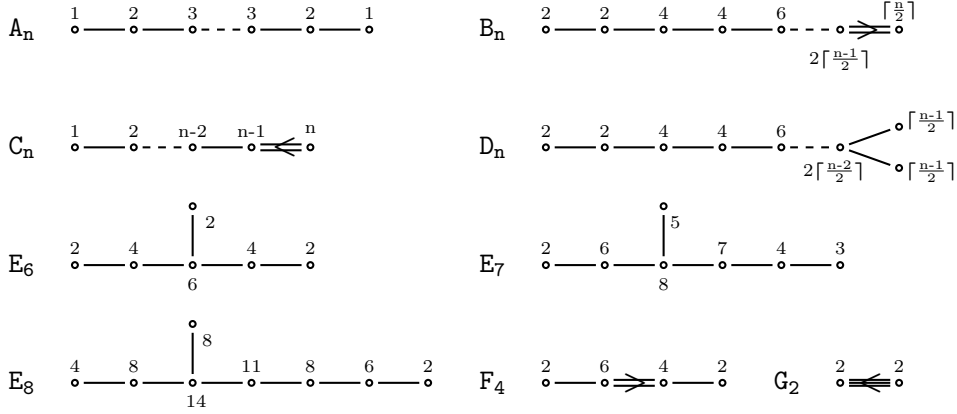

The paper is organized as follows: In Section 2 we introduce definitions and basic notations, in Section 3 we prove Theorem 1.

Acknowledgements

T.B. was funded by the DFG-priority program 1388 Representation Theory, grant "LI 990/10-1", G.F. was partially funded the grant "FO 867/1-1", L.B. and C.D. were partially funded within the framework of this program. The main work of this article has been conducted during a workshop organized at the University of Glasgow, and all authors would like to thank the Glasgow Mathematical Journal Trust Fund, the Edinburgh Mathematical Journal and especially the University of Glasgow for this opportunity.

Mathematisches Institut, Universität zu Köln, Germany (T.B., L.B., C.D.)
 Mathematisches Institut, Universität Bonn, Germany, School of Mathematics and Statistics, University of Glasgow, UK (G.F.)

2. PRELIMINARIES

Let \mathfrak{g} be a simple Lie algebra of rank n . We fix a Cartan subalgebra \mathfrak{h} and a triangular decomposition $\mathfrak{g} = \mathfrak{n}^+ \oplus \mathfrak{h} \oplus \mathfrak{n}^-$. The set of roots (resp. positive roots) of \mathfrak{g} is denoted R (resp. R^+), θ denotes the highest root. Let α_i, ω_i $i = 1, \dots, n$ be the simple roots and the fundamental weights. Let W be the Weyl group associated to the simple roots and $w_0 \in W$ the longest element. For $\alpha \in R^+$ we fix a \mathfrak{sl}_2 triple $\{e_\alpha, f_\alpha, h_\alpha = [e_\alpha, f_\alpha]\}$. The integral weights and the dominant integral weights are denoted P and P^+ .

Let $\{x_1, x_2, \dots\}$ be an ordered basis of \mathfrak{g} , then $U(\mathfrak{g})$ denotes the universal enveloping algebra of \mathfrak{g} with PBW basis $\{x_{i_1} \cdots x_{i_m} \mid m \in \mathbb{Z}_{\geq 0}, i_1 \leq i_2 \leq \dots \leq i_m\}$.

2.1. Modules. For $\lambda \in P^+$ we consider the irreducible \mathfrak{g} -Module $V(\lambda)$ with highest weight λ . Then $V(\lambda)$ admits a decomposition into \mathfrak{h} -weight spaces, $V(\lambda) = \bigoplus_{\tau \in P} V(\lambda)_\tau$ with $V(\lambda)_\lambda$ and $V(\lambda)_{w_0(\lambda)}$, the highest and lowest weight spaces, being one dimensional. Let v_λ denote the highest weight vector, $v_{w_0(\lambda)}$ denote the lowest weight vector satisfying

$$e_\alpha v_\lambda = 0, \quad \forall \alpha \in R^+; \quad f_\alpha v_{w_0(\lambda)} = 0, \quad \forall \alpha \in R^+.$$

We have $U(\mathfrak{n}^-).v_\lambda \cong V(\lambda) \cong U(\mathfrak{n}^+).v_{w_0(\lambda)}$.

The comultiplication ($x \mapsto x \otimes 1 + 1 \otimes x$) provides a \mathfrak{g} -module structure on $V(\lambda) \otimes V(\mu)$. This module decomposes into irreducible components, where the Cartan component generated by the highest weight vector $v_\lambda \otimes v_\mu$ is isomorphic to $V(\lambda + \mu)$.

2.2. PBW-filtration. The Hilbert-Poincaré series of the PBW-graded module $V(\lambda)^a := \bigoplus_{s \geq 0} V(\lambda)_s / V(\lambda)_{s-1}$ is the polynomial

$$\begin{aligned} p_\lambda(q) &= \sum_{s \geq 0} \dim(V(\lambda)_s / V(\lambda)_{s-1}) q^s \\ &= 1 + \dim(V(\lambda)_1 / V(\lambda)_0) q + \dim(V(\lambda)_2 / V(\lambda)_1) q^2 + \dots \end{aligned}$$

and we define the PBW-degree of $V(\lambda)$ to be $\deg(p_\lambda(q))$.

It is easy to see that $\mathfrak{n}^+.(U(\mathfrak{n}^-)_s.v_\lambda) \subseteq U(\mathfrak{n}^-)_s.v_\lambda \quad \forall s \geq 0$ (see also [FFL11a]) and hence $U(\mathfrak{n}^+).V(\lambda)_s \subseteq V(\lambda)_s$. Let s_λ be minimal such that $v_{w_0(\lambda)} \in V(\lambda)_{s_\lambda}$. Then $V(\lambda) = U(\mathfrak{n}^+).v_{w_0(\lambda)} \subseteq V(\lambda)_{s_\lambda}$ and

Corollary. $s_\lambda = \deg(p_\lambda(q))$ and

$$V(\lambda) = V(\lambda)_{s_\lambda}.$$

2.3. Graded weight spaces. The PBW filtration is compatible with the decomposition into \mathfrak{h} -weight spaces:

$$\dim V(\lambda)_\tau = \sum_{s \geq 0} \dim(V(\lambda)_s / V(\lambda)_{s-1}) \cap V(\lambda)_\tau.$$

So we can define for every weight τ the Hilbert-Poincaré polynomial:

$$p_{\lambda,\tau}(q) = \sum_{s \geq 0} \dim(V(\lambda)_s / V(\lambda)_{s-1})_\tau q^s \quad \text{and then} \quad p_\lambda(q) = \sum_{\tau \in P} p_{\lambda,\tau}(q).$$

A natural question is, if we can extend our results to these polynomials? If the weight space $V(\lambda)_\tau$ is one-dimensional, then $p_{\lambda,\tau}(q)$ is a power of q . For $\tau = \lambda$ this is constant 1, for $\tau = w_0(\lambda)$, the lowest weight, this is $q^{\deg p_\lambda(q)}$ as we have seen in Corollary 2.2. A first approach to study these polynomials can be found in [CF13].

2.4. Graded Kostant partition function. For the readers convenience we recall here the *graded Kostant partition function* (see [Kos59]), which counts the number of decompositions of a fixed weight into a sum of positive roots, and how it is related to our study. We consider the power series and its expansion:

$$\prod_{\alpha > 0} \frac{1}{(1 - qe^\alpha)}, \quad \sum_{\nu \in P} P_\nu(q) e^\nu.$$

We have immediately $\text{char } S(\mathfrak{n}^-) = \sum_{\nu \in P} P_\nu(q) e^{-\nu}$.

Remark. For a polynomial $p(q) = \sum_{i=0}^n a_i q^i$, we denote $\text{mindeg } p(q)$ the minimal j such that $a_j \neq 0$. Then we have obviously

$$(2.1) \quad \text{mindeg } p_{\lambda, \nu}(q) \geq \text{mindeg } P_{\lambda - \nu}(q).$$

We will use this inequality for the very special case $\nu = w_0(\lambda)$ in the proof of Theorem 1.

We see from Theorem 1 that this inequality is a proper inequality for certain cases in exceptional type as well as $B_n D_n$ (this has been noticed also in [CF13]).

3. PROOF OF THEOREM 1

In this section we will provide a proof of Theorem 1. For a fixed $1 \leq i \leq \text{rank } \mathfrak{g}$, we will give a monomial $u \in U(\mathfrak{n}^-)$ of the predicted degree mapping the highest weight vector v_{ω_i} to the lowest weight vector $v_{w_0(\omega_i)}$. We then show that there is no monomial of smaller degree satisfying this.

To write down these monomials explicitly, let us denote θ_{X_n} the highest root of a Lie algebra of type X_n . We set further (using the indexing from [Hum72]):

- In the A_n -case, Y_{n-2} the type of the Lie algebra generated by the simple roots $\{\alpha_2, \dots, \alpha_{n-1}\}$.
- In the B_n, D_n -case, Y_{n-k} the type of the Lie algebra generated by the simple roots $\{\alpha_{k+1}, \dots, \alpha_n\}$.
- In the exceptional and symplectic cases, $\theta_{X_n} = c_k \omega_k$ for some k , Y_{n-1} the type of the Lie algebra generated by the simple roots $\{\alpha_1, \dots, \alpha_n\} \setminus \{\alpha_k\}$.

Let $u \in U(\mathfrak{n}^-)$ be one of the monomials in Figure 1. It can be seen easily from Figure 1 that $u = f_{\theta_{X_n}}^{a_i^\vee} u_1$, where $a_i^\vee = w_i(h_{\theta_{X_n}})$ and u_1 is the monomial in Figure 1 corresponding to the restriction of ω_i to the Lie subalgebra of type $Y_{n-\ell}$. If we denote \mathfrak{n}_1^- the lower part in the triangular decomposition of the Lie subalgebra of type $Y_{n-\ell}$, then $u_1 \in U(\mathfrak{n}_1^-)$.

Let $u = f_{\theta_1}^{b_1} f_{\theta_2}^{b_2} \dots f_{\theta_r}^{b_r}$. Note that all f_{θ_j} commute and it is easy to see that $\theta_j(h_{\theta_{j+p}}) = 0$, $\forall p \geq 0$ (since θ_j is a sum of fundamental weights, which are all orthogonal to the simple roots of the Lie algebra with highest root θ_{j+p}) and $b_j = \omega_i(h_{\theta_j})$.

The Weyl group W acts on $V(\omega_i)$ and if v is an extremal weight vector of weight μ , then $w.v$ is a nonzero extremal weight vector of weight $w(\mu)$. Further if $w = s_\alpha$ (reflection at a root α) and $\mu(h_\alpha) \geq 0$, then $w.v = c^* f_\alpha^{\mu(h_\alpha)}.v$ for some $c^* \in \mathbb{C}^*$. Now consider $w = s_{\theta_r} \dots s_{\theta_1}$, where s_{θ_j} is the reflection at the root θ_j . Then we have $w.v_{\omega_i} = v_{w_0(\omega_i)} = u.v_{\omega_i} \neq 0$ in $V(\omega_i)$. So we obtain an upper estimate for the degree.

In general the degree of u is bigger than the minimal degree coming from Kostant's graded partition function (2.1). For A_n, C_n the degrees coincide and hence we are done in these cases.

We will prove Theorem 1 for the remaining cases X_n by induction on the rank of the Lie algebra. So we want to prove that if $p \in U(\mathfrak{n}^-)$ with $p.v_{\omega_i} = v_{w_0(\omega_i)}$ then $\deg(p) \geq \deg(u)$, where u is from Figure 1.

Consider the induction start, e.g. $\omega_i = \theta_{X_n}$, then the minimal degree is obviously 2. The maximal non-vanishing power of $f_{\theta_{X_n}}$ is certainly a_i^\vee and $f_{\theta_{X_n}}^{a_i^\vee}.v_{\omega_i}$ is the highest weight vector of a simple module of fundamental weight for the Lie algebra $Y_{n-\ell}$ defined as above. By induction we know that if $q \in U(\mathfrak{n}_1^-)$ with $q.(f_{\theta_{X_n}}^{a_i^\vee}.v_{\omega_i}) = v_{w_0(\omega_i)}$ then $\deg(q) \geq \deg(u_1)$.

| | | |
|-------|----------------------------------|--|
| X_n | $\omega_i = \theta_{X_n}$ | $f_{\theta_{X_n}}^2$ |
| A_n | ω_i | $f_{\theta_{A_n}} f_{\theta_{A_{n-2}}} \cdots f_{\theta_{A_{n+2-2\min\{i,n-i\}}}}$ |
| C_n | ω_i | $f_{\theta_{C_n}} f_{\theta_{C_{n-1}}} \cdots f_{\theta_{C_{n+1-i}}}$ |
| B_n | ω_{2i} | $f_{\theta_{B_n}}^2 f_{\theta_{B_{n-2}}}^2 \cdots f_{\theta_{B_{n+2-2i}}}^2$ |
| B_n | ω_{2i+1} | $f_{\theta_{B_n}}^2 f_{\theta_{B_{n-2}}}^2 \cdots f_{\theta_{B_{n-2i}}}^2 f_{\alpha_{2i+1}}$ |
| B_n | n even, ω_n | $f_{\theta_{B_n}} f_{\theta_{B_{n-2}}} \cdots f_{\theta_{B_2}}$ |
| B_n | n odd, ω_n | $f_{\theta_{B_n}} f_{\theta_{B_{n-2}}} \cdots f_{\theta_{B_2}} f_{\alpha_n}$ |
| D_n | ω_{2i} | $f_{\theta_{D_n}}^2 f_{\theta_{D_{n-2}}}^2 \cdots f_{\theta_{D_{n+2-2i}}}^2$ |
| D_n | ω_{2i+1} | $f_{\theta_{D_n}}^2 f_{\theta_{D_{n-2}}}^2 \cdots f_{\theta_{D_{n-2i}}}^2 f_{\alpha_{2i+1}}$ |
| D_n | n even, $\omega_i, i = n-1, n$ | $f_{\theta_{D_n}} f_{\theta_{D_{n-2}}} \cdots f_{\theta_{D_4}} f_{\alpha_i}$ |
| D_n | n odd, $\omega_i, i = n-1, n$ | $f_{\theta_{D_n}} f_{\theta_{D_{n-2}}} \cdots f_{\theta_{D_5}} f_{\theta_{A_4}}$ |
| E_6 | ω_1, ω_6 | $f_{\theta_{E_6}} f_{\theta_{A_5}}$ |
| E_6 | ω_3, ω_5 | $f_{\theta_{E_6}}^2 f_{\theta_{A_5}} f_{\theta_{A_3}}$ |
| E_6 | ω_4 | $f_{\theta_{E_6}}^3 f_{\theta_{A_5}} f_{\theta_{A_3}} f_{\alpha_4}$ |
| E_7 | ω_2 | $f_{\theta_{E_7}}^2 f_{\theta_{D_6}} f_{\theta_{D_4}} f_{\alpha_2}$ |
| E_7 | ω_3 | $f_{\theta_{E_7}}^3 f_{\theta_{D_6}} f_{\theta_{D_4}} f_{\alpha_3}$ |
| E_7 | ω_4 | $f_{\theta_{E_7}}^4 f_{\theta_{D_6}}^2 f_{\theta_{D_4}}^2$ |
| E_7 | ω_5 | $f_{\theta_{E_7}}^3 f_{\theta_{D_6}}^2 f_{\theta_{D_4}} f_{\alpha_5}$ |
| E_7 | ω_6 | $f_{\theta_{E_7}}^2 f_{\theta_{D_6}}^2$ |
| E_7 | ω_7 | $f_{\theta_{E_7}} f_{\theta_{D_6}} f_{\alpha_7}$ |
| E_8 | ω_1 | $f_{\theta_{E_8}}^2 f_{\theta_{E_7}}^2$ |
| E_8 | ω_2 | $f_{\theta_{E_8}}^3 f_{\theta_{E_7}}^2 f_{\theta_{D_6}} f_{\theta_{D_4}} f_{\alpha_2}$ |
| E_8 | ω_3 | $f_{\theta_{E_8}}^4 f_{\theta_{E_7}}^3 f_{\theta_{D_6}} f_{\theta_{D_4}} f_{\alpha_3}$ |
| E_8 | ω_4 | $f_{\theta_{E_8}}^6 f_{\theta_{E_7}}^4 f_{\theta_{D_6}}^2 f_{\theta_{D_4}}^2$ |
| E_8 | ω_5 | $f_{\theta_{E_8}}^5 f_{\theta_{E_7}}^3 f_{\theta_{D_6}}^2 f_{\theta_{D_4}} f_{\alpha_5}$ |
| E_8 | ω_6 | $f_{\theta_{E_8}}^4 f_{\theta_{E_7}}^2 f_{\theta_{D_6}}^2$ |
| E_8 | ω_7 | $f_{\theta_{E_8}}^3 f_{\theta_{E_7}} f_{\theta_{D_6}} f_{\alpha_7}$ |
| F_4 | ω_2 | $f_{\theta_{F_4}}^3 f_{\theta_{C_3}} f_{\theta_{A_2}} f_{\alpha_2}$ |
| F_4 | ω_3 | $f_{\theta_{F_4}}^2 f_{\theta_{C_3}} f_{\theta_{C_2}}$ |
| F_4 | ω_4 | $f_{\theta_{F_4}} f_{\theta_{C_3}}$ |
| G_2 | ω_1 | $f_{\theta_{G_2}} f_{\alpha_1}$ |

FIGURE 1.

First we suppose $f_{\theta_{X_n}}^{a_i^\vee} \cdot v_{\omega_i}$ is a factor of p , so $p = f_{\theta_{X_n}}^{a_i^\vee} p'$ and then by weight considerations $p' \in U(\mathfrak{n}_1^-)$. Then $p' \cdot (f_{\theta_{X_n}}^{a_i^\vee} \cdot v_{\omega_i}) = v_{w_0(\omega_i)}$ (the lowest weight vector in $V(\omega_i)$ as well as in the simple submodule). Therefore $\deg(p') \geq \deg(u_1)$ which implies $\deg(p) \geq \deg(u)$.

Suppose now the maximal power of $f_{\theta_{X_n}}$ in p is $f_{\theta_{X_n}}^{a_i^\vee - k}$, $k \geq 0$ and $\deg(p) < \deg(u)$. Let X_n be of type B_n, D_n or exceptional, then $\theta_{X_n} = \omega_j$ and we denote

$$R_s^+ = \{\alpha \in R^+ \mid w_j(h_\alpha) = s\},$$

Then $R_2^+ = \{\theta_{X_n}\}$ and if $\beta \in R_1^+$ then $\theta_{X_n} - \beta \in R_1^+$. By weight reasons $p = f_{\theta_{X_n}}^{a_i^\vee - k} f_{\beta_1} \cdots f_{\beta_{2k}} p_1$ for some $\beta_1, \dots, \beta_{2k} \in R_1^+$ and some polynomial p_1 in root vectors of roots in R_0^+ . We have to show that $p.v_{\omega_i} = 0 \in V(\omega_i)^a$ and we will use induction on k for that: The induction start is $k = 0$. The induction step is for $k \geq 1$:

$$\begin{aligned} 0 = p_1 f_{\theta_{X_n}}^{a_i^\vee + k} .v_{\omega_i} &= (e_{\theta_{X_n} - \beta_1}) \cdots (e_{\theta_{X_n} - \beta_{2k}}) p_1 f_{\theta_{X_n}}^{a_i^\vee + k} .v_{\omega_i} \\ &= c f_{\theta_{X_n}}^{a_i^\vee - k} f_{\beta_1} \cdots f_{\beta_{2k}} p_1 .v_{\omega_i} + \sum_{\ell > 0}^k f_{\theta_{X_n}}^{a_i^\vee - k + \ell} q_\ell .v_{\omega_i} \end{aligned}$$

for some $c \in \mathbb{C}^*$, $q_\ell \in U(\mathfrak{n}^-)$. For $0 \leq \ell < k$ all the summands are equals to zero by induction (on k). For $\ell = k$, we recall our assumption $\deg(p) < \deg(u)$ and so $\deg(q_k) < \deg(u_1)$ which implies $f^{a_i^\vee} q_k .v_{\omega_i} = 0$. So we can conclude $f_{\theta_{X_n}}^{a_i^\vee - k} f_{\beta_1} \cdots f_{\beta_{2k}} p_1 .v_{\omega_i} = 0$.

REFERENCES

- [BD14] T. Backhaus and C. Desczyk. PBW filtration: Feigin-Fourier-Littelmann modules via Hasse diagrams. arXiv:1407.73664, 2014.
- [BF14] R. Biswal and G. Fourier. PBW degenerated Demazure module for abelian radicals. Preprint, 2014.
- [CF13] I. Cherednik and E. Feigin. Extremal part of the PBW-filtration and E-polynomials. Preprint: arXiv:1306.3146, 2013.
- [CIL14] G. Cerulli Irelli and M. Lanini. Degenerate flag varieties of type A and C are Schubert varieties. Preprint arXiv:1403.2889, 2014.
- [CILL14] G. Cerulli Irelli, M. Lanini, and P. Littelmann. Preprint, 2014.
- [Fei12] Evgeny Feigin. \mathbb{G}_a^M degeneration of flag varieties. *Selecta Math. (N.S.)*, 18(3):513–537, 2012.
- [FFL11a] E. Feigin, G. Fourier, and P. Littelmann. PBW filtration and bases for irreducible modules in type A_n . *Transform. Groups*, 16(1):71–89, 2011.
- [FFL11b] E. Feigin, G. Fourier, and P. Littelmann. PBW filtration and bases for symplectic Lie algebras. *Int. Math. Res. Not. IMRN*, 1(24):5760–5784, 2011.
- [FFL13a] E. Feigin, G. Fourier, and P. Littelmann. Favourable modules: Filtrations, polytopes, Newton-Okounkov bodies and flat degenerations. arXiv:1306.1292v3, 2013.
- [FFL13b] E. Feigin, G. Fourier, and P. Littelmann. PBW-filtration over \mathbb{Z} and compatible bases for $v(\lambda)$ in type A_n and C_n . *Springer Proceedings in Mathematics and Statistics*, 40:35–63, 2013.
- [FM14] E. Feigin and I. Makedonskyi. Nonsymmetric Macdonald polynomials, Demazure modules and PBW filtration. Preprint arXiv:1407.6316, 2014.
- [Fou14a] G. Fourier. New homogeneous ideals for current algebras: Filtrations, fusion products and Pieri rules. Preprint: arXiv:1403.4758, 2014.
- [Fou14b] G. Fourier. PBW filtration for rectangular Demazure modules. Preprint, 2014.
- [Gor11] A. Gornitsky. Essential signatures and canonical bases in irreducible representations of the group G_2 . Diploma thesis, 2011.
- [Hum72] James E. Humphreys. *Introduction to Lie algebras and representation theory*. Springer-Verlag, New York, 1972. Graduate Texts in Mathematics, Vol. 9.
- [Kos59] Bertram Kostant. A formula for the multiplicity of a weight. *Trans. Amer. Math. Soc.*, 93:53–73, 1959.

MATHEMATISCHES INSTITUT, UNIVERSITÄT ZU KÖLN, GERMANY

E-mail address: tbackha@math.uni-koeln.de

E-mail address: lbossing@math.uni-koeln.de

E-mail address: cdesczyk@math.uni-koeln.de

MATHEMATISCHES INSTITUT, UNIVERSITÄT BONN, GERMANY
SCHOOL OF MATHEMATICS AND STATISTICS, UNIVERSITY OF GLASGOW, UK
E-mail address: gislain.fourier@glasgow.ac.uk

3. PBW FILTRATION: FEIGIN–FOURIER–LITTELMANN MODULES VIA HASSE DIAGRAMS

TEODOR BACKHAUS AND CHRISTIAN DESCZYK

ABSTRACT. We study the PBW filtration on the irreducible highest weight representations of simple complex finite-dimensional Lie algebras. This filtration is induced by the standard degree filtration on the universal enveloping algebra. For certain rectangular weights we provide a new description of the associated graded module in terms of generators and relations. We also construct a basis parametrized by the integer points of a normal polytope. The main tool we use is the Hasse diagram defined via the standard partial order on the positive roots. As an application we conclude that all representations considered in this paper are Feigin-Fourier-Littelmann modules.

INTRODUCTION

We recall briefly the construction of the PBW filtration. We consider a simple complex finite-dimensional Lie algebra \mathfrak{g} and a triangular decomposition $\mathfrak{g} = \mathfrak{n}^+ \oplus \mathfrak{h} \oplus \mathfrak{n}^-$. We denote by $V(\lambda)$ the irreducible finite-dimensional module of highest weight λ and by v_λ a highest weight vector, then we have $V(\lambda) = U(\mathfrak{n}^-)v_\lambda$. The degree filtration $U(\mathfrak{n}^-)_s$ on the universal enveloping algebra $U(\mathfrak{n}^-)$ over \mathfrak{n}^- is defined by:

$$U(\mathfrak{n}^-)_s = \text{span}\{x_1 \cdots x_l \mid x_i \in \mathfrak{n}^-, l \leq s\}.$$

This filtration induces the PBW filtration on $V(\lambda)$, where the s -th filtration component is given by $V(\lambda)_s = U(\mathfrak{n}^-)_s v_\lambda$. The associated graded space $V(\lambda)^a$, with respect to the PBW filtration, is a $S(\mathfrak{n}^-)$ -module generated by v_λ , where $S(\mathfrak{n}^-)$ is the symmetric algebra over \mathfrak{n}^- . Then we have for $I(\lambda) \subseteq S(\mathfrak{n}^-)$ the annihilator of the generating element:

$$V(\lambda)^a = S(\mathfrak{n}^-)v_\lambda \cong S(\mathfrak{n}^-)/I(\lambda).$$

There are some natural questions (see also [FFoL11a]):

- Is it possible to describe $V(\lambda)^a$ explicitly as a $S(\mathfrak{n}^-)$ -module, i.e. is it possible to describe the generators of the ideal $I(\lambda)$?
- Is it possible to find an explicit combinatorial description of a monomial basis of $V(\lambda)^a$?

We will call such a basis a *Feigin-Fourier-Littelmann* or just FFL basis and $V(\lambda)^a$ a FFL module, if the bases of $V(m\lambda)^a$, $m \in \mathbb{Z}_{\geq 0}$ are parametrized by the integer points of a normal polytope $P(m)$.

For both questions there is a positive answer in the cases of \mathfrak{sl}_n and \mathfrak{sp}_{2n} for arbitrary dominant integral weights (see [FFoL11a] and [FFoL11b]). Further the second question is positively answered for \mathfrak{G}_2 (see [Gor11]). In this paper we focus on certain rectangular weights and prove the following theorem:

Main Theorem. *Let \mathfrak{g} be a simple complex finite-dimensional Lie algebra and $\lambda = m\omega_i$, $m \in \mathbb{Z}_{\geq 0}$ be a rectangular weight, where \mathfrak{g} and ω_i appear in the same row of Table 1. Further let $V(\lambda)^a \cong S(\mathfrak{n}^-)/I(\lambda)$. Then there is a positive answer for both questions above, in particular:*

- $I(\lambda) = S(\mathfrak{n}^-) \left(U(\mathfrak{n}^+) \circ \text{span} \{ f_\beta^{(\lambda, \beta^\vee)+1} \mid \beta \in \Delta_+ \} \right)$.
- $V(\lambda)^a$ is a FFL module.

Here we denote with Δ_+ the set of positive roots of \mathfrak{g} .

| Type of \mathfrak{g} | weight ω | Type of \mathfrak{g} | weight ω |
|------------------------|------------------------------------|------------------------|----------------------|
| A_n | $\omega_k, 1 \leq k \leq n$ | E_6 | ω_1, ω_6 |
| B_n | ω_1, ω_n | E_7 | ω_7 |
| C_n | ω_1 | F_4 | ω_4 |
| D_n | $\omega_1, \omega_{n-1}, \omega_n$ | G_2 | ω_1 |

TABLE 1. Solved cases

Remark 1. *The Theorem above implies the existence of a normal polytope $P(m\omega_i)$ such that the integer points $S(m\omega_i)$ parametrize a basis of $V(m\omega_i)$. This polytope is the m -th Minkowski sum of the polytope $P(\omega_i)$ corresponding to $V(\omega_i)$. In general this is not true for different fundamental weights, because the number of integer points in the Minkowski sum is too small. For example in the case of $\mathfrak{g} = \mathfrak{sl}_5$, we have $|(P(\omega_1) + P(\omega_2) + P(\omega_3) + P(\omega_4)) \cap \mathbb{Z}_{\geq 0}^N| = 1023$ and $\dim V(\omega_1 + \omega_2 + \omega_3 + \omega_4) = 1024$.*

Remark 2. *The bases obtained in [FFoL11a], which were conjectured by Vinberg (see [V05]) and obtained in [FFoL11b] are different from our bases. This is due to a different choice of the total order on the monomials in $S(\mathfrak{n}^-)$. As a consequence the induced normal polytopes are also different. Nevertheless in the cases (A_n, ω_k) the corresponding projective toric varieties are isomorphic. In contrast, these are in general not isomorphic to the toric varieties corresponding to Gelfand-Tsetlin polytopes investigated in [GL97] and [KM05].*

We explain briefly the methods used in our paper. Our main tool is the Hasse diagram of \mathfrak{g} given by the standard partial order on the positive roots of \mathfrak{g} . We associate to this directed graph a normal polytope $P(\lambda) = P(m\omega_i) \subset \mathbb{R}_{\geq 0}^N$ via the directed paths. If the Hasse diagram satisfies certain properties, the set of integer points $S(\lambda) = P(\lambda) \cap \mathbb{Z}_{\geq 0}^N$ parametrizes a FFL basis of $V(\lambda)^a$. So we reduce the questions above to the combinatorics of the Hasse diagram and provide a general procedure which uses the structure of the Hasse diagram. As an important application we show that the modules $V(m\omega_i)$, $m \in \mathbb{Z}_{\geq 0}$ are FFL modules, where ω_i appears in Table 1.

Except for the cases listed in Table 1 it is much more involved to obtain a polytope which parametrizes a FFL basis. Even in the cases (B_n, ω_1) , (F_4, ω_4) and (G_2, ω_1) we have to change the Hasse diagram slightly, to be able to apply our procedure.

The property of being a FFL module implies some nice consequences. For example the corresponding degenerate flag varieties are normal and Cohen-Macaulay. Further there is an explicit representation theoretical description of the corresponding homogeneous coordinate rings. Another important property is the interpretation of the describing polytopes as Newton-Okounkov bodies (see [FFoL13] and for more details on Newton-Okounkov bodies see [KK12] and [HK13]).

In the recent years it turned out that the PBW theory has a lot of connections to many areas of representation theory. For example to the geometric representation theory: Schubert varieties ([CIL14], [CLaL14]) and degenerate flag varieties ([FFiL11], [Fei11], [Fei12], [CIFR12] and [Hag13]). Further there are connections to combinatorial representation theory for example to Schur functions ([Fou14]), combinatorics of crystal basis ([Kus13a], [Kus13b]) and Macdonald polynomials ([CF13], [FM14]). A purely combinatorial research on the FFL polytopes can be found in [ABS11]. A general formula for the maximal degree of $V(\lambda)^a$ for arbitrary dominant integral weights λ is provided in [BBDF14].

Our paper is organized as follows:

In Section 1 we introduce the constructions and tools we use. Furthermore we state our Main Theorems and provide the connection to FFL modules. In Section 2 we prove that all polytopes considered in this paper are normal. Sections 3, 4 and 5 are devoted to the proof of our Main Theorems. In Section 4 we calculate explicitly FFL bases of $V(\omega)$ for all cases listed in Table 1. Finally in the Appendix we give some explicit examples of Hasse diagrams and normal polytopes.

1. PBW FILTRATION

1.1. Definitions. Let \mathfrak{g} be a simple complex finite-dimensional Lie algebra and let $\mathfrak{g} = \mathfrak{n}^+ \oplus \mathfrak{h} \oplus \mathfrak{n}^-$ be a triangular decomposition.

For a dominant integral weight λ we denote by $V(\lambda)$ the irreducible \mathfrak{g} -module with highest weight λ . We fix a highest weight vector $v_\lambda \in V(\lambda)$. Then we have $V(\lambda) = U(\mathfrak{n}^-)v_\lambda$. The degree filtration $U(\mathfrak{n}^-)_s$ on $U(\mathfrak{n}^-)$ is defined by:

$$(1.1) \quad U(\mathfrak{n}^-)_s = \text{span}\{x_1 \cdots x_l \mid x_i \in \mathfrak{n}^-, l \leq s\}.$$

In particular, $U(\mathfrak{n}^-)_0 = \mathbb{C}\mathbf{1}$. So we have an increasing chain of subspaces:

$U(\mathfrak{n}^-)_0 \subseteq U(\mathfrak{n}^-)_1 \subseteq U(\mathfrak{n}^-)_2 \subseteq \dots$. The filtration (1.1) induces a filtration on $V(\lambda)$: $V(\lambda)_s = U(\mathfrak{n}^-)_s v_\lambda$, the PBW filtration.

We consider the associated graded space $V(\lambda)^a$ of $V(\lambda)$ defined by:

$$(1.2) \quad V(\lambda)^a = \bigoplus_{s \in \mathbb{Z}_{\geq 0}} V(\lambda)_s / V(\lambda)_{s-1}, \quad V(\lambda)_{-1} = \{0\}.$$

Let $\Delta_+ \subset \mathfrak{h}^*$ be the set of positive roots of \mathfrak{g} and $\Phi_+ = \{\alpha_1, \dots, \alpha_n\} \subset \Delta_+$ the subset of simple roots, where $n \in \mathbb{N}$ is the rank of the Lie algebra \mathfrak{g} . Further we denote by $f_\beta \in \mathfrak{n}^-$ the root vector corresponding to $\beta \in \Delta_+$. Let $\langle \lambda, \beta^\vee \rangle = \frac{2(\lambda, \beta)}{(\beta, \beta)}$, where $\beta^\vee = \frac{2\beta}{(\beta, \beta)}$ is the coroot of β and (\cdot, \cdot) is the Killing form. We define

$$\mathfrak{n}_\lambda^- := \text{span}\{f_\beta \mid \langle \lambda, \beta^\vee \rangle \geq 1\} \subset \mathfrak{n}^-.$$

Throughout this paper we focus on certain rectangular weights $\lambda = m\omega_i$, $m \in \mathbb{Z}_{\geq 0}$ (see Table 1).

Let $\beta = \sum_{j=1}^n n_j \alpha_j$, $n_j \in \mathbb{Z}_{\geq 0}$ be a positive root with $n_i \geq 1$. Then we have for the coroot $\beta^\vee = \sum_{j=1}^n n_j^\vee \alpha_j^\vee$: $n_i^\vee \geq 1$. Conversely starting with a coroot β^\vee , with $n_i^\vee \geq 1$ we have for the corresponding positive root β : $n_i \geq 1$. Hence, independent of the choice of $m \geq 1$:

$$\mathfrak{n}_{\omega_i}^- = \mathfrak{n}_{m\omega_i}^- \subset \mathfrak{n}^-$$

is the Lie subalgebra spanned by those root vectors f_β , where α_i is a summand of β .

From the PBW-Theorem we get $U(\mathfrak{n}_\lambda^-)^a = S(\mathfrak{n}_\lambda^-) = \mathbb{C}[f_\beta \mid \langle \lambda, \beta^\vee \rangle \geq 1]$, where $S(\mathfrak{n}_\lambda^-)$ is the symmetric algebra over \mathfrak{n}_λ^- .

Remark 1.1.1. (i) We have $V(\lambda) = U(\mathfrak{n}_\lambda^-)v_\lambda$. The action of $U(\mathfrak{n}_\lambda^-)$ on $V(\lambda)$ induces the structure of a $S(\mathfrak{n}_\lambda^-)$ -module on $V(\lambda)^a$ and

$$(1.3) \quad V(\lambda)^a = S(\mathfrak{n}^-)v_\lambda = S(\mathfrak{n}_\lambda^-)v_\lambda.$$

(ii) The action of $U(\mathfrak{n}^+)$ on $V(\lambda)$ induces the structure of a $U(\mathfrak{n}^+)$ -module on $V(\lambda)^a$. Note for $e_\alpha \in \mathfrak{n}^+ \hookrightarrow U(\mathfrak{n}^+)$, $f_\beta \in \mathfrak{n}_\lambda^- \hookrightarrow S(\mathfrak{n}_\lambda^-)$, $[e_\alpha, f_\beta]$ is not in general an element of $S(\mathfrak{n}_\lambda^-)$, but for $f_\nu \in S(\mathfrak{n}^-) \setminus S(\mathfrak{n}_\lambda^-)$ we have $f_\nu v_\lambda = 0$. That follows from the well known description (see [Hum72]) of $V(\lambda)$:

$$(1.4) \quad V(\lambda) = U(\mathfrak{n}^-) / \langle f_\beta^{\langle \lambda, \beta^\vee \rangle + 1} \mid \beta \in \Delta_+ \rangle.$$

Equation (1.3) shows that $V(\lambda)^a$ is a cyclic $S(\mathfrak{n}_\lambda^-)$ -module and hence there is an ideal $I_\lambda \subseteq S(\mathfrak{n}_\lambda^-)$ such that $V(\lambda)^a \simeq S(\mathfrak{n}_\lambda^-) / I_\lambda$, where I_λ is the annihilating ideal of v_λ . We have therefore the following projections:

$$S(\mathfrak{n}^-) \rightarrow S(\mathfrak{n}^-) / \langle f_\beta \mid \langle \lambda, \beta^\vee \rangle = 0 \rangle = S(\mathfrak{n}_\lambda^-) \rightarrow S(\mathfrak{n}_\lambda^-) / I_\lambda.$$

Hence, although we work with \mathfrak{n}_λ^- , we actually consider \mathfrak{n}^- -modules. So our aims in this paper are

- To describe $V(\lambda)^a$ as a $S(\mathfrak{n}_\lambda^-)$ -module, i. e. describe explicitly generators of the ideal I_λ .
- To find a basis of $V(\lambda)^a$ parametrized by integer points of a normal polytope $P(\lambda)$ (see (1.10)).

To achieve these goals we have to introduce further terminology. We denote the set of positive roots associated to \mathfrak{n}_λ^- by

$$(1.5) \quad \Delta_+^\lambda = \{\beta \in \Delta_+ \mid \langle \lambda, \beta^\vee \rangle \geq 1\} =: \{\beta_1, \dots, \beta_N\} \subseteq \Delta_+, \quad |\Delta_+^\lambda| = N \in \mathbb{Z}_{\geq 0}.$$

Example 1.1.2. We write (r_1, r_2, \dots, r_n) for the sum: $\sum_{k=1}^n r_k \alpha_k$. Let \mathfrak{g} be of type \mathbf{A}_4 and $\lambda = \omega_3$, the third fundamental weight. Then we have:

$$\begin{aligned} \Delta_+^{\omega_3} = \{ & \beta_1 = (1, 1, 1, 1), \beta_2 = (0, 1, 1, 1), \beta_3 = (1, 1, 1, 0), \\ & \beta_4 = (0, 0, 1, 1), \beta_5 = (0, 1, 1, 0), \beta_6 = (0, 0, 1, 0) \} \subset \Delta_+. \end{aligned}$$

We choose a total order \prec on Δ_+^λ :

$$(1.6) \quad \beta_1 \prec \beta_2 \prec \dots \prec \beta_{N-1} \prec \beta_N.$$

We assume that this order satisfies the following conditions:

- (i) Let \geq be the standard partial order on the positive roots, then

$$\beta_i > \beta_j \Rightarrow \beta_i \prec \beta_j.$$

- (ii) Let $\beta_i = (r_1, \dots, r_n)$, $\beta_j = (t_1, \dots, t_n)$ and we define the height as the sum over these entries: $\text{ht}(\beta_i) = \sum_{i=1}^n r_i$, $\text{ht}(\beta_j) = \sum_{i=1}^n t_i$. Then

$$\text{ht}(\beta_i) > \text{ht}(\beta_j) \Rightarrow \beta_i \prec \beta_j.$$

- (iii) If β_i and β_j are not comparable in the sense of (i) and (ii), then $\beta_i \prec \beta_j \Leftrightarrow \beta_i$ is greater than β_j lexicographically, i.e. there exists $1 \leq k \leq n$, such that $r_k > t_k$ and $r_i = t_i$ for $1 \leq i < k$.

Remark 1.1.3. *The explicit order of the roots depends on the Lie algebra and the chosen weight, see Section 4. But in all cases considered in this paper we have $\beta_1 = \theta$, the highest root of \mathfrak{g} and β_N is the simple root α_i .*

In order to make our equations more readable we write for $1 \leq i \leq N$: $f_i = f_{\beta_i}$ and $s_i = s_{\beta_i}$. We associate to the multi-exponent $\mathbf{s} = (s_i)_{i=1}^N \in \mathbb{Z}_{\geq 0}^N$ the element

$$(1.7) \quad f^{\mathbf{s}} = \prod_{i=1}^N f_i^{s_i} \in S(\mathfrak{n}_{\lambda}^-),$$

and define the degree of $f^{\mathbf{s}}v_{\lambda} \neq 0$ in $V(\lambda)^a$ by $\deg(f^{\mathbf{s}}v_{\lambda}) = \deg(f^{\mathbf{s}}) = \sum_{i=1}^N s_i$, or $\deg(f^{\mathbf{s}}v_{\lambda}) = 0$ if $f^{\mathbf{s}}v_{\lambda} = 0$. We extend \prec to the homogeneous lexicographical total order on the monomials of $S(\mathfrak{n}_{\lambda}^-)$ (resp. multi-exponents).

Let $\mathbf{s}, \mathbf{t} \in \mathbb{Z}_{\geq 0}^N$ be two multi-exponents. We say $f^{\mathbf{s}} \succ f^{\mathbf{t}}$ or $\mathbf{s} \succ \mathbf{t}$ if

- $\deg(f^{\mathbf{s}}) > \deg(f^{\mathbf{t}})$ or
- $\deg(f^{\mathbf{s}}) = \deg(f^{\mathbf{t}})$ and $\exists 1 \leq k \leq N : (s_k > t_k) \wedge \forall k < j \leq N : (s_j = t_j)$.

For example: $f_1^1 f_2^2 f_3^0 \prec f_1^2 f_2^0 f_3^1 \prec f_1^1 f_2^0 f_3^2$.

Remark 1.1.4. *Because the action of \mathfrak{n}^+ on $V(\lambda)$ is induced by the adjoint action, we know that $V(\lambda)_s, s \in \mathbb{Z}_{\geq 0}$ is stable under the action of \mathfrak{n}^+ : for $e \in \mathfrak{n}^+$ and $x_1 \cdots x_s v_{\lambda} \in V(\lambda)_s$ we have*

$$e.x_1 \cdots x_s v_{\lambda} = \sum_{i=1}^s x_1 \cdots x_{i-1} [e, x_i] x_{i+1} \cdots x_s v_{\lambda} \in V(\lambda)_s.$$

Hence $V(\lambda)_s$ is a $U(\mathfrak{n}^+)$ -module. So for $f^{\mathbf{t}}v_{\lambda}$ in $V(\lambda)^a = \bigoplus_{s \geq 0} V(\lambda)_s / V(\lambda)_{s-1}$ we have $\deg(uf^{\mathbf{t}}v_{\lambda}) \in \{0, \deg(f^{\mathbf{t}}v_{\lambda})\}$ for all $u \in U(\mathfrak{n}^+)$.

The next Lemma is devoted to give a better understanding of the module $V(\lambda)^a$, but we will not need it to prove our main statements.

Lemma 1.1.5. *Let $f^{\mathbf{m}} \in S(\mathfrak{n}^-)$ with $f^{\mathbf{m}}v_{\lambda} \neq 0$ in $V(\lambda)^a$ and weight $\text{wt}(f^{\mathbf{m}}) = \lambda - w_0(\lambda)$, where w_0 is the longest element in the Weyl group of \mathfrak{g} and $w_0(\lambda)$ is the lowest weight of $V(\lambda)$. Then*

$$\deg(f^{\mathbf{n}}) \leq \deg(f^{\mathbf{m}}), \quad \forall f^{\mathbf{n}}v_{\lambda} \neq 0 \in V(\lambda)^a.$$

Proof. Let $v_{w_0(\lambda)}$ be a lowest weight vector such that:

$$V(\lambda) = U(\mathfrak{n}^+)v_{w_0(\lambda)}.$$

Hence we can interpret $V(\lambda)$ as a lowest weight module. The lowest weight $w_0(\lambda)$ is in the Weyl group orbit of λ , thus $\dim V(\lambda)_{w_0(\lambda)} = 1 = \dim V(\lambda)_{\lambda}$. So there is a minimal $s \in \mathbb{Z}_{\geq 0}$ such that: $V(\lambda)_{w_0(\lambda)} \subseteq V(\lambda)_s$. Further there exists a scalar $c \in \mathbb{C}$ with $f^{\mathbf{m}}v_{\lambda} = cv_{w_0(\lambda)}$.

For an arbitrary element $f^{\mathbf{n}}v_{\lambda} \neq 0 \in V(\lambda)^a$ we fix the order of the factors to obtain $f^{\mathbf{n}}v_{\lambda} \in V(\lambda)$. Then there exists an element $x \in U(\mathfrak{n}^+)$ such that: $f^{\mathbf{n}}v_{\lambda} = x(f^{\mathbf{m}}v_{\lambda})$. This implies with Remark 1.1.4: $\deg(f^{\mathbf{n}}) \leq \deg(f^{\mathbf{m}})$. \square

Associated to the set \mathfrak{n}_{λ}^- we define a directed graph $H(\mathfrak{n}_{\lambda}^-)_{\mathfrak{g}} := (\Delta_+^{\lambda}, E)$. The set of vertices is given by Δ_+^{λ} and the set of edges E is constructed as follows:

$$\forall 1 \leq i, j \leq N : (\beta_i \xrightarrow{k} \beta_j) \in E \Leftrightarrow \exists \alpha_k \in \Phi_+ : \beta_i - \beta_j = \alpha_k.$$

We call this directed graph *Hasse diagram* of \mathfrak{g} associated to λ . For our further considerations $H(\mathfrak{n}_{\lambda}^-)_{\mathfrak{g}}$ is the most important tool.

Example 1.1.6. The Hasse diagram $H(\mathfrak{n}_{\omega_3}^-)_{\mathfrak{sl}_5}$ is given by:

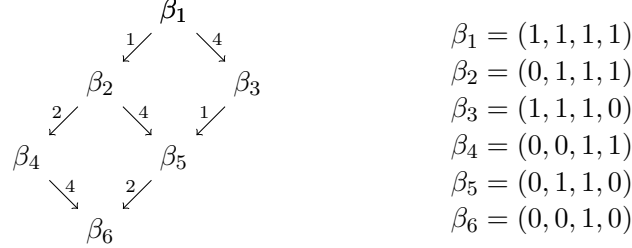

We define an ordered sequence of roots in Δ_+^λ : $(\beta_{i_1}, \dots, \beta_{i_r})$ with $\beta_{i_j} \prec \beta_{i_{j+1}}$ to be a *directed path* from β_{i_1} to β_{i_r} .

Remark 1.1.7. For our purposes we want to allow the trivial path (\emptyset) and any ordered subsequence of a directed path to be a directed path again. So in Example 1.1.6 $(\beta_1, \beta_2, \beta_4, \beta_6)$ and $(\beta_1, \beta_2, \beta_6)$ are two possible directed paths.

In general it is possible that two edges in $H(\mathfrak{n}_\lambda^-)_{\mathfrak{g}}$, one ending in a root β and one starting in β , have the same label:

$$\gamma \xrightarrow{k} \beta \xrightarrow{k} \delta.$$

We call this construction a *k-chain* (of length 2).

Associated to $H(\mathfrak{n}_\lambda^-)_{\mathfrak{g}}$ we construct two subsets $D_\lambda, \overline{D}_\lambda \subset \mathcal{P}(\Delta_+^\lambda)$ of the power set of Δ_+^λ : For $\mathbf{p} \in \mathcal{P}(\Delta_+^\lambda)$ we define

$$(1.8) \quad \mathbf{p} \in D_\lambda \Leftrightarrow \mathbf{p} = \{\beta_{i_1}, \dots, \beta_{i_r}\},$$

for a directed path $(\beta_{i_1}, \dots, \beta_{i_r})$ in $H(\mathfrak{n}_\lambda^-)_{\mathfrak{g}}$. So from now on by (1.8) we interpret $\mathbf{p} \in D_\lambda$ as a directed path in $H(\mathfrak{n}_\lambda^-)_{\mathfrak{g}}$.

Remark 1.1.8. Let $\beta_i, \beta_j \in \Delta_+^\lambda$ be arbitrary. Then there exist a $\mathbf{p} \in D_\lambda$ with $\beta_i, \beta_j \in \mathbf{p}$ if and only if $\beta_i - \beta_j$ or $\beta_j - \beta_i$ is a non-negative linear combination of simple roots.

Remark 1.1.9. A staircase walk from $(0,0)$ to (n,n) beyond the diagonal in a $n \times n$ -lattice is called a *Dyck path*. In the general \mathbf{A}_n -case ([FFoL11a]) the constructed directed paths are Dyck paths in this sense. To be consistent with their notation we call our directed paths D_λ also *Dyck paths*.

Further we define the set of *co-chains* by

$$(1.9) \quad \overline{D}_\lambda := \{\overline{\mathbf{p}} \in \mathcal{P}(\Delta_+^\lambda) \mid |\overline{\mathbf{p}} \cap \mathbf{p}| \leq 1, \forall \mathbf{p} \in D_\lambda\}.$$

If necessary we use an additional index $\overline{D}_\lambda^{\text{type of } \mathfrak{g}}$, to distinguish which type of \mathfrak{g} we consider. We want to consider the integral points of a polytope which is connected to D_λ in a very natural way. Fix $\lambda = m\omega_i$, with $m \in \mathbb{Z}_{\geq 0}$. Let

$$(1.10) \quad P(m\omega_i) = \{\mathbf{x} \in \mathbb{R}_{\geq 0}^N \mid \sum_{\beta_j \in \mathbf{p}} x_j \leq m, \forall \mathbf{p} \in D_{\omega_i}\},$$

be the *associated polytope* to D_{ω_i} . Denote by $S(m\omega_i)$ the integer points in $P(m\omega_i)$: $S(m\omega_i) = P(m\omega_i) \cap \mathbb{Z}_{\geq 0}^N$. We define the map

$$\text{supp}_1 : S(\omega_i) \rightarrow \mathcal{P}(\Delta_+^{\omega_i}), \text{supp}_1(\mathbf{s}) = \{\beta_j \mid s_j > 0\}.$$

For $\mathbf{s} \in S(\omega_i)$ we have with (1.9) immediately $\text{supp}_1(\mathbf{s}) \in \overline{D}_{\omega_i}$. Conversely every $\overline{\mathbf{p}} \in \overline{D}_{\omega_i}$ has a non-empty pre-image. With $\mathbf{s} \in \{0, 1\}^N$ we conclude that supp_1 is injective and that we have the immediate proposition:

Proposition 1.1.10. *The map $\text{supp}_1 : S(\omega_i) \rightarrow \overline{D}_{\omega_i}$ is a bijection.* \square

Hence in Section 4 it is sufficient to determine the co-chains in $H(\mathfrak{n}_{\omega_i}^-)_{\mathfrak{g}}$ to find the elements in $S(\omega_i)$. Now we are able to formulate our main statements.

1.2. Main statements. Let \mathfrak{g} be a simple complex finite-dimensional Lie algebra and $\lambda = m\omega_i$ be a rectangular weight, with $\langle \omega_i, \theta^\vee \rangle = 1$ and $m \in \mathbb{Z}_{\geq 0}$, where θ is the highest root of \mathfrak{g} . Further we assume that $H(\mathfrak{n}_{\omega_i}^-)_{\mathfrak{g}}$ has no k -chains of length 2. In the following table we list up all cases where these assumptions are satisfied. Additionally in the cases (\mathbf{B}_n, ω_1) , (\mathbf{F}_4, ω_4) and (\mathbf{G}_2, ω_1) , we can rewrite $H(\mathfrak{n}_{\omega_i}^-)_{\mathfrak{g}}$ in a diagram without k -chains of length 2:

| Type of \mathfrak{g} | weight ω_i | Type of \mathfrak{g} | weight ω_i |
|------------------------|------------------------------------|------------------------|----------------------|
| \mathbf{A}_n | $\omega_k, 1 \leq k \leq n$ | \mathbf{E}_6 | ω_1, ω_6 |
| \mathbf{B}_n | ω_1, ω_n | \mathbf{E}_7 | ω_7 |
| \mathbf{C}_n | ω_1 | \mathbf{F}_4 | ω_4 |
| \mathbf{D}_n | $\omega_1, \omega_{n-1}, \omega_n$ | \mathbf{G}_2 | ω_1 |

TABLE 2. Solved cases

Let $I(m\omega_i) \subset S(\mathfrak{n}^-)$ be the ideal such that $V(m\omega_i)^a = S(\mathfrak{n}^-)/I(m\omega_i)$.

Theorem A.

$$I(m\omega_i) = S(\mathfrak{n}^-) \left(U(\mathfrak{n}^+) \circ \text{span}\{f_\beta^{\langle m\omega_i, \beta^\vee \rangle + 1} \mid \beta \in \Delta_+\} \right).$$

Proof. This statement follows by Theorem 5.1.4. \square

Theorem B. $\mathbb{B}_{m\omega_i} = \{f^{\mathbf{s}}v_{m\omega_i} \mid \mathbf{s} \in S(m\omega_i)\}$ is a FFL basis of $V(m\omega_i)^a$.

Proof. In Section 2 we show that the polytope $P(m\omega_i)$ is normal. By Theorem 3.1.4 we conclude that $\mathbb{B}_{m\omega_i}$ is a spanning set for $V(m\omega_i)^a$. After fixing the order of the factors, with Theorem 5.1.2 we have a FFL basis of $V(m\omega_i)$. Because this basis is monomial and $V(m\omega_i) \cong V(m\omega_i)^a$ as vector spaces, we conclude that $\mathbb{B}_{m\omega_i}$ is a FFL basis of $V(m\omega_i)^a$. \square

1.3. Applications. To state an important consequence of Theorem A and Theorem B we give the definitions of *essential monomials* due to Vinberg (see [V05], [Gor11]) and *Feigin-Fourier-Littelmann* (FFL) modules due to [FFoL13]. Let λ be a dominant integral weight. Recall that we have a homogeneous lexicographical total order \prec on the set of multi-exponents induced by the order on Δ_+^λ :

$$\beta_1 \prec \beta_2 \prec \cdots \prec \beta_N.$$

In the following we fix a ordering on the factors in a vector

$$(1.11) \quad f^{\mathbf{p}}v_\lambda = f_N^{p_N} f_{N-1}^{p_{N-1}} \cdots f_1^{p_1} v_\lambda.$$

Definition 1.3.1. (i) We call a multi-exponent $\mathbf{p} \in \mathbb{Z}_{\geq 0}^N$ *essential* if

$$f^{\mathbf{p}}v_\lambda \notin \text{span}\{f^{\mathbf{q}}v_\lambda \mid \mathbf{q} \prec \mathbf{p}\}.$$

(ii) Define $\text{es}(V(\lambda)) \subset \mathbb{Z}_{\geq 0}^N$ to be the set of *essential multi-exponents*.

By [FFoL13, Section 1] $\{f^{\mathbf{p}}v_\lambda \mid \mathbf{p} \in \text{es}(V(\lambda))\}$ is a basis of $V(\lambda)^a$ and of $V(\lambda)$.

Let $M = U(\mathfrak{n}^-)v_M$ and $M' = U(\mathfrak{n}^-)v_{M'}$ be two cyclic modules. Then we denote with $M \odot M' := U(\mathfrak{n}^-)(v_M \otimes v_{M'}) \subset M \otimes M'$ the *Cartan component* and we write $M^{\odot n} := M \odot \cdots \odot M$ (n -times).

Definition 1.3.2. *We call a cyclic module M a FFL module if:*

- (i) *There exists a normal polytope $P(M)$ such that $\text{es}(M) = S(M)$, where $S(M)$ is the set of lattice points in $P(M)$.*
- (ii) *$\forall n \in \mathbb{N} : \dim M^{\odot n} = |nS(M)|$, where $nS(M)$ is the n -fold Minkowski sum of $S(M)$.*

Corollary 1.3.3. *For the cases of Table 2 $V(m\omega_i)$ is a FFL module.*

Proof. Proposition 2.3.1 shows that $P(m\omega_i)$ is a normal polytope. By Theorem B a basis of $V(m\omega_i)$ is given by $\mathbb{B}_{m\omega_i}$, hence with Lemma 5.1.1 we have $S(m\omega_i) = \text{es}(V(m\omega_i))$.

Let $n \in \mathbb{N}$ be arbitrary, then $\dim V(m\omega_i)^{\odot n} = \dim V(nm\omega_i)$. Again by Theorem B we have $\dim V(nm\omega_i) = |S(nm\omega_i)|$. Because $P(nm\omega_i)$ is a normal polytope and therefore satisfies the Minkowski sum property, we conclude $|S(nm\omega_i)| = |nS(m\omega_i)|$. \square

Remark 1.3.4. *We note that in [FFoL13] the FFL modules are called favourable modules.*

2. NORMAL POLYTOPES

Our goal in this section is to show, that the polytopes defined in (1.10) are normal. A convex lattice polytope $P \subset \mathbb{R}^K$, $K \in \mathbb{Z}_{\geq 0}$, i.e. P is the convex hull of finitely many integer points, is called normal, if the set of integer points in the m -th dilation mP is the m -fold Minkowski sum of the integer points in P .

To achieve our goal we will prove the normality condition for a larger class of polytopes in a more abstract setting than in Section 1.

2.1. General setting. Let $\Delta = \{z_1, z_2, \dots, z_K\}$ be a finite, non-empty set with a total order: $z_1 \succ z_2 \succ \cdots \succ z_K$. We extend \succ to the (non-homogeneous) lexicographic order on $\mathcal{P}(\Delta)$, the power set of Δ . Let $D = \{\mathbf{p}_1, \dots, \mathbf{p}_t\} \subset \mathcal{P}(\Delta)$ be an arbitrary subset.

Remark 2.1.1. (i) *To illustrate this non-homogeneous lexicographical order we give for $K \geq 3$ an example:*

$$\{z_1, z_2\} \succ \{z_1\} \succ \{z_2, z_3\}$$

(ii) *Let $\mathbf{p} = \{z_{i_1}, \dots, z_{i_r}\} \in \mathcal{P}(\Delta)$ be an arbitrary set. We always assume without loss of generality (wlog): $z_{i_1} \succ \cdots \succ z_{i_r}$.*

We can associate a collection of polytopes to D in a natural way:

$$(2.1) \quad P(m) = \{\mathbf{x} \in \mathbb{R}_{\geq 0}^K \mid \sum_{z_j \in \mathbf{p}} x_j \leq m, \forall \mathbf{p} \in D\}, m \in \mathbb{Z}_{\geq 0}.$$

To work with these polytope, in particular with the elements in D , we define the following.

Definition 2.1.2.

- (1) For $\mathbf{p} \in \mathcal{P}(\Delta)$ define $\mathbf{p}_{\min} = \min\{z \in \mathbf{p}\}$ and \mathbf{p}_{\max} analogously.
(2) Let $\mathbf{p}, \mathbf{q} \in \mathcal{P}(\Delta)$, $\mathbf{p} = \{z_{i_1}, \dots, z_{i_r}\}$, $\mathbf{q} = \{z_{j_1}, \dots, z_{j_s}\}$ with $\mathbf{p}_{\min} = \mathbf{q}_{\max}$.
Then we define the concatenation of \mathbf{p} and \mathbf{q} by

$$\mathbf{p} \cup \mathbf{q} = \{z_{i_1}, z_{i_2}, \dots, z_{i_r} = z_{j_1}, z_{j_2}, \dots, z_{j_s}\} \in \mathcal{P}(\Delta).$$

2.2. Normality condition.

Definition 2.2.1. Assume $D \subset \mathcal{P}(\Delta)$ has the following properties:

- (1) Subsets of elements in D are again in D :

$$\forall A \subset \mathbf{p} \in D : A \in D.$$

- (2) Every $z \in \Delta$ lies at least in one element of D :

$$\bigcup_{\mathbf{p} \in D} \mathbf{p} = \Delta$$

- (3) The concatenation of two elements in D , if possible, lies again in D :

$$\forall \mathbf{p}, \mathbf{q} \in D \text{ with } \mathbf{p}_{\min} = \mathbf{q}_{\max} : \mathbf{p} \cup \mathbf{q} \in D.$$

Then we call $D \subset \mathcal{P}(\Delta)$ a set of Dyck paths.

We define for $m \in \mathbb{Z}_{\geq 0}$, $\text{supp}_m : S(m) \rightarrow \mathcal{P}(\Delta)$, by

$$\mathbf{t} = (t_z)_{z \in \Delta} \mapsto \text{supp}_m(\mathbf{t}) = \{z \in \Delta \mid t_z > 0\}.$$

Note that the map supp_m is in general not injective. Furthermore we have $\text{supp}_1(S(1)) \subseteq \text{supp}_m(S(m))$, because of $S(1) \subseteq S(m)$ and $\text{supp}_m|_{S(1)} = \text{supp}_1$.

Remark 2.2.2. Let $D \subset \mathcal{P}(\Delta)$ be a set of Dyck paths, then $P(m)$ defined in (2.1) is a bounded convex polytope for all $m \in \mathbb{Z}_{\geq 0}$.

By the definition of $P(m)$ and the second property of D , which guarantees that each $z \in \Delta$ lies in at least one Dyck path, we have $t_z \in \{0, 1\}, \forall z \in \Delta$, for $\mathbf{t} \in S(1)$. Hence supp_1 is an injective map and we get an induced (non-homogeneous) total order on $S(1)$.

Now we want to give a characterization of the image of supp_1 .

Remark 2.2.3. Let $D \subset \mathcal{P}(\Delta)$ be a set of Dyck paths, then

$$(2.2) \quad \text{supp}_1(S(1)) = \{A \in \mathcal{P}(\Delta) \mid |A \cap \mathbf{p}| \leq 1, \forall \mathbf{p} \in D\} =: \Gamma.$$

" \subseteq ": Assume there is an element $\mathbf{t} \in S(1)$ with $\text{supp}_1(\mathbf{t}) = A \in \mathcal{P}(\Delta)$ and $|A \cap \mathbf{p}| > 1$ for some $\mathbf{p} \in D$. Then we have $\sum_{z \in A \cap \mathbf{p}} t_z > 1$, since $t_z > 0, \forall z \in A$. And so we have: $\sum_{z \in \mathbf{p}} t_z > 1$. But this is a contradiction to the assumption $\mathbf{t} \in S(1)$.

" \supseteq ": Let $B \in \Gamma$ be arbitrary. Associated to B we define $\mathbf{q}^B \in \mathbb{Z}_{\geq 0}^K$ by $q_z^B = 1$ if $z \in B$ and $q_z^B = 0$ else. By the definition of Γ we have for every Dyck path $\mathbf{p} \in D$: $\sum_{z \in \mathbf{p}} q_z^B \leq 1$. Hence $\mathbf{q}^B \in S(1)$ with $\text{supp}_1(\mathbf{q}^B) = B$.

Let $\mathbf{s} \in S(m), m \in \mathbb{Z}_{\geq 0}, \mathbf{s} \neq 0$ be an arbitrary non-zero element. Consider $\text{supp}_m(\mathbf{s}) \in \mathcal{P}(\Delta)$, we have $\mathcal{P}(\text{supp}_m(\mathbf{s})) \subseteq \mathcal{P}(\Delta)$. Let

$$(2.3) \quad \nabla = (\text{supp}_1(S(1)) \cap \mathcal{P}(\text{supp}_m(\mathbf{s}))) \subseteq \mathcal{P}(\Delta).$$

Note that ∇ is a total ordered, non-empty set, because $S(1)$ contains all unit vectors and $\mathbf{s} \neq 0$ by assumption. So there is a unique maximal element (with respect to \succ), denoted by $M_{\mathbf{s}} \in \nabla$.

Lemma 2.2.4. *Let D be a set of Dyck paths, $\mathbf{s} \in S(m)$ non-zero and $\mu \in M_{\mathbf{s}}$. Then we have $s_{\nu} = 0$ for all $\nu \in \Delta$ such that ($\nu \succ \mu$ and $\exists \mathbf{q} \in D : \nu, \mu \in \mathbf{q}$).*

Proof. We assume the contrary. That means there exists $\nu \in \Delta$ with $\nu \succ \mu$, $s_{\nu} \neq 0$ and a Dyck path $\mathbf{p} \in D$ such that $\nu, \mu \in \mathbf{p}$. Define

$$V := \{\tau \in M_{\mathbf{s}} \mid \exists \mathbf{q} \in D : \nu, \tau \in \mathbf{q}, \nu \succ \tau\} \subset M_{\mathbf{s}}$$

and $M'_{\mathbf{s}} := (\{\nu\} \cup M_{\mathbf{s}}) \setminus V$. By assumption we have $\mu \in V$ and so $|V| \geq 1$. Further we have $M'_{\mathbf{s}} \in \mathcal{P}(\text{supp}_m(\mathbf{s}))$ and we want to show that $M'_{\mathbf{s}} \in \text{supp}_1(S(1))$.

We assume that this is not the case. So there exists some $\mathbf{b} \in D$ such that $|M'_{\mathbf{s}} \cap \mathbf{b}| > 1$. By the definition of V this can only happen, if there exists a $\alpha \in M_{\mathbf{s}}$ with $\alpha \succ \nu$ and $\alpha, \nu \in \mathbf{b}$. The following picture is intended to give a better understanding of the foregoing situation.

$$\begin{array}{ccccccc} & & & & \tau_1 & & \\ & & & & \uparrow & & \\ & & & & \cdot & \xrightarrow{\nu} & \cdot & \xrightarrow{\mathbf{p}} & \mu, \quad \tau_1, \tau_2 \in V. \\ & & & & \downarrow & & \tau_2 & & \\ \alpha & \longrightarrow & \cdot & \longrightarrow & \cdot & & & & \end{array}$$

We can assume wlog that $\mathbf{b}_{\min} = \nu$ and $\mathbf{p}_{\max} = \nu$, because subsets of Dyck paths are again Dyck paths. So the concatenation $\mathbf{b} \cup \mathbf{p} \in D$ is defined and we have $\alpha, \nu \in \mathbf{b} \cup \mathbf{p}$. But then, because of $\alpha, \nu \in M_{\mathbf{s}}$: $|M_{\mathbf{s}} \cap \mathbf{b}| > 1$, which is a contradiction to $M_{\mathbf{s}} \in \text{supp}_1(S(1))$.

So for all $\mathbf{q} \in D$ we have $|M'_{\mathbf{s}} \cap \mathbf{q}| \leq 1$. By that and with $M'_{\mathbf{s}} \in \mathcal{P}(\Delta)$ we conclude $M'_{\mathbf{s}} \in \text{supp}_1(S(1))$. Therefore $M'_{\mathbf{s}} \in \nabla$ and by construction, because \succ is a lexicographic order, $M'_{\mathbf{s}} \succ M_{\mathbf{s}}$, which is a contradiction to the maximality of $M_{\mathbf{s}}$. So the assumption on the existence of ν was wrong, which proves the Lemma. \square

Proposition 2.2.5. *Let $D \subset \mathcal{P}(\Delta)$ be a set of Dyck paths, then we have for the integer points $S(m)$ of the polytopes $P(m)$ associated to D :*

$$(2.4) \quad S(m-1) + S(1) = S(m), \quad \forall m \in \mathbb{Z}_{\geq 1},$$

where the left-hand side (lhs) of (2.4) is the Minkowski sum of $S(m-1)$ and $S(1)$.

Proof. Let $m \geq 1$. From the definition of $P(m)$ and of the Minkowski sum follows $S(m-1) + S(1) \subset S(m)$. So it is sufficient to show that

$$(2.5) \quad S(m-1) + S(1) \supset S(m)$$

holds. For that let $\mathbf{s} = (s_z)_{z \in \Delta} \in S(m) \setminus S(m-1)$ be an arbitrary element. We show that there exists an integer point $\mathbf{t}^1 \in S(1) \setminus \{0\}$ such that: $\mathbf{s} - \mathbf{t}^1 \in S(m-1)$. We define for $M_{\mathbf{s}}$ defined as in (2.3):

$$(2.6) \quad \mathbf{t}^1 := \text{supp}_1^{-1}(M_{\mathbf{s}}) \in S(1) \setminus \{0\}.$$

This element is unique because of the injectivity of supp_1 . Now we consider the integer point $\mathbf{s} - \mathbf{t}^1$. We know that there are no negative entries, because $s_z = 0$ implies for all $A \in \nabla : z \notin A$ and so $t_z^1 = 0$. Hence $\mathbf{s} - \mathbf{t}^1 \in S(m)$ and so the second step is to show that $\mathbf{s} - \mathbf{t}^1$ lies already in $S(m-1)$.

To achieve that we assume contrary $\mathbf{s} - \mathbf{t}^1 \in S(m) \setminus S(m-1)$, i.e. that there is a Dyck path $\mathbf{p} \in D$ such that:

$$\sum_{z \in \mathbf{p}} (s_z - t_z^1) = m.$$

Since $\mathbf{s} \in S(m)$ we have:

$$(2.7) \quad m = \sum_{z \in \mathbf{p}} (s_z - t_z^1) = \underbrace{\sum_{z \in \mathbf{p}} s_z}_{\leq m} - \underbrace{\sum_{z \in \mathbf{p}} t_z^1}_{\geq 0} \Rightarrow \sum_{z \in \mathbf{p}} s_z = m \text{ and } \sum_{z \in \mathbf{p}} t_z^1 = 0.$$

We want to construct another Dyck path $\bar{\mathbf{p}} \in D$ such that $\sum_{z \in \bar{\mathbf{p}}} s_z > m$. Let $\beta \in \Delta$ be maximal with the property $\beta \in \mathbf{p} \wedge s_\beta > 0$. In particular, since $\sum_{z \in \mathbf{p}} (s_z - t_z^1) = m$ we have $\mathbf{p} \cap M_{\mathbf{s}} = \emptyset$ and so $\beta \notin M_{\mathbf{s}}$. We define

$$\mathbf{p}' = \mathbf{p} \setminus \{\gamma \in \mathbf{p} \mid \gamma \succ \beta\},$$

which is an element of D since subsets of Dyck paths are again Dyck paths. By construction we have

$$\sum_{z \in \mathbf{p}'} s_z = m = \sum_{z \in \mathbf{p}} s_z.$$

There are two possibilities to extend the path \mathbf{p}' with a further Dyck path $\mathbf{p}'' \in D$:

$$(i) \mathbf{p}''_{\min} = \beta \text{ or } (ii) \mathbf{p}''_{\max} = \mathbf{p}_{\min}.$$

To obtain a path $\bar{\mathbf{p}} = \mathbf{p}'' \cup \mathbf{p}'$ (respectively $\bar{\mathbf{p}} = \mathbf{p}' \cup \mathbf{p}''$) with $\sum_{z \in \bar{\mathbf{p}}} s_z > m$, the extension \mathbf{p}'' has to satisfy the following condition: $\mathbf{p}'' \cap M_{\mathbf{s}} \neq \emptyset$.

Assume we are in the case (ii). Then there exists $\tau \in \mathbf{p}'' \cap M_{\mathbf{s}}$ with $s_\tau > 0$. Further we have $s_\beta > 0$ and $\tau, \beta \in \mathbf{p}' \cup \mathbf{p}'' = \bar{\mathbf{p}} \in D$. By construction we have $\beta \prec \tau$ and so Lemma 2.2.4 implies that $s_\beta = 0$. This is a contradiction to $s_\beta > 0$.

So we want to show the existence of a path $\mathbf{p}'' \in D$ with condition (i) and $\mathbf{p}'' \cap M_{\mathbf{s}} \neq \emptyset$. We assume contrary there is no such Dyck path \mathbf{p}'' :

$$(2.8) \quad \forall \mathbf{q} \in D \text{ with } \mathbf{q}_{\min} = \beta : \mathbf{q} \cap M_{\mathbf{s}} = \emptyset.$$

Under this assumption and by using Lemma 2.2.4 we will show:

$$(2.9) \quad \forall \mathbf{q} \in D \text{ with } \beta \in \mathbf{q} : \mathbf{q} \cap M_{\mathbf{s}} = \emptyset.$$

Assume (2.9) is not true, so there is some $\beta \neq \tau \in \mathbf{q} \cap M_{\mathbf{s}}$ for $\mathbf{q} \in D$ with $\beta \in \mathbf{q}$. Then we have two cases.

Let $\tau \succ \beta$, then τ and β lie in \mathbf{q} . Now the path from τ to β is again a Dyck path. But this is a contradiction to Assumption (2.8).

Let $\beta \succ \tau$, by $\tau \in \mathbf{q} \cap M_{\mathbf{s}}$ we have $t_\tau^1 \neq 0$. Then Lemma 2.2.4 implies $s_\beta = 0$, which is a contradiction to the choice of β .

Therefore (2.9) holds. Recall the properties of $M_{\mathbf{s}}$. We have

$$M_{\mathbf{s}} = \text{supp}_1(\mathbf{t}^1) \in \mathcal{P}(\Delta) \text{ with } |M_{\mathbf{s}} \cap \mathbf{q}| \leq 1, \forall \mathbf{q} \in D.$$

Now consider $M'_{\mathbf{s}} := M_{\mathbf{s}} \cup \{\beta\} \in \mathcal{P}(\text{supp}_m(\mathbf{s}))$. We will show that $M'_{\mathbf{s}} \in \text{supp}_1(S(1))$.

For $\mathbf{q} \in D$ with $\beta \in \mathbf{q}$ we have $|M'_{\mathbf{s}} \cap \mathbf{q}| = 1$ by (2.9).

For $\mathbf{q} \in D$ with $\beta \notin \mathbf{q}$ we have $|M'_{\mathbf{s}} \cap \mathbf{q}| \leq 1$ by $|M_{\mathbf{s}} \cap \mathbf{q}| \leq 1$.

We conclude $M'_{\mathbf{s}} \in \text{supp}_1(S(1))$ and so

$$M'_{\mathbf{s}} \in \nabla = \text{supp}_1(S(1)) \cap \mathcal{P}(\text{supp}_m(\mathbf{s})).$$

But with $M'_s \succ M_s$ we get a contradiction to the maximality of M_s .
So Assumption (2.8) was wrong and there exists

$$\mathbf{p}'' \in D \text{ with } \mathbf{p}''_{\min} = \beta : \mathbf{p}'' \cap M_s \neq \emptyset.$$

We recall that $\beta \notin M_s$ and therefore $\tilde{\mathbf{p}} \neq \{\beta\}$. Define the concatenation of \mathbf{p}'' and \mathbf{p}' in β as $\bar{\mathbf{p}} := \mathbf{p}'' \cup \mathbf{p}' \in D$ which is indeed defined because $\mathbf{p}''_{\min} = \beta = \mathbf{p}'_{\max}$. From Definition 2.2.1(3) we know that $\bar{\mathbf{p}}$ is a Dyck path. Now by construction we conclude

$$\sum_{z \in \bar{\mathbf{p}}} s_z = \underbrace{\sum_{z \in \mathbf{p}''} s_z}_{>0} + \underbrace{\sum_{z \in \mathbf{p}'} s_z}_{=m} > m.$$

But this is a contradiction to the choice of $\mathbf{s} \in S(m)$ and the assumption $\sum_{z \in \mathbf{p}} (s_z - t_z^1) = m$ was wrong. We conclude $\mathbf{s} - \mathbf{t}^1 \in S(m-1)$ and with $\mathbf{t}^1 \in S(1)$ we have $\mathbf{s} \in S(m-1) + S(1)$. Finally we get $S(m) \subset S(m-1) + S(1)$. \square

2.3. Consequences. We recall the construction of the Hasse diagram and the Dyck paths from Section 1 and show that we can apply Proposition 2.2.5 to this setup. Let $\lambda = m\omega_i$ as before and we set $\Delta = \Delta_+^{\omega_i}, D = D_{\omega_i}$. Then we have for the associated polytopes:

$$P(m) = P(m\omega_i).$$

For $\Delta_+^\lambda = \{\beta_1, \dots, \beta_N\}$ we chose in Section 1 the order $\beta_1 \prec \dots \prec \beta_N$. To apply Proposition 2.2.5 we can use the same order on the positive roots and extend this order to the (non-homogeneous) lexicographical order on $\mathcal{P}(\Delta_+^{\omega_i})$ as before. We want to show that the Dyck paths defined in Section 1 are Dyck paths in the sense of Definition 2.2.1.

(1) Every $\mathbf{p}' \subset \mathbf{p} \in D_{\omega_i}$ is again a Dyck path: We saw that any ordered subset of a directed path in $H(\mathfrak{n}_{\omega_i}^-)_{\mathfrak{g}}$ is again a Dyck path.

(2) For each $\beta \in \Delta_+^{\omega_i}$ there is at least one $\mathbf{p} \in D_{\omega_i}$ such that $\beta \in \mathbf{p}$: The set of vertices in $H(\mathfrak{n}_{\omega_i}^-)_{\mathfrak{g}}$ is exactly $\Delta_+^{\omega_i}$. By construction we allow paths of cardinality one, so for example the path (β) contains β .

(3) Let $\mathbf{p}, \mathbf{p}' \in D_{\omega_i}$ be two Dyck paths, such that $\mathbf{p}_{\min} = \mathbf{p}'_{\max}$. Then there are directed paths W, W' in $H(\mathfrak{n}_{\omega_i}^-)_{\mathfrak{g}}$ realizing \mathbf{p} and \mathbf{p}' such that the end point of W is equal to the starting point of W' . We consider the directed path, which we obtain by the concatenation of the directed paths W and W' . This directed path realizes $\mathbf{p} \cup \mathbf{p}'$. Hence $\mathbf{p} \cup \mathbf{p}'$ lies in D_{ω_i} .

With Proposition 2.2.5 we get immediately for $S(m\omega_i) = P(m\omega_i) \cap \mathbb{Z}_{\geq 0}^N, m \in \mathbb{Z}_{\geq 0}$:

Proposition 2.3.1. $S(m\omega_i) = S((m-1)\omega_i) + S(\omega_i), m \in \mathbb{Z}_{\geq 1}$. \square

Finally we conclude that the polytopes constructed in (1.10) are normal convex lattice polytopes.

3. SPANNING PROPERTY

Let \mathfrak{g} be a simple complex finite-dimensional Lie algebra, $\lambda = m\omega$ be a rectangular dominant integral weight such that $\langle \omega, \theta^\vee \rangle = 1$, where θ is the highest root in Δ_+ and $m \in \mathbb{Z}_{\geq 0}$. In this section we show that $\mathbb{B}_\lambda = \{f^{\mathbf{s}} v_\lambda \mid \mathbf{s} \in S(\lambda)\}$ is a spanning set for $V(\lambda)^a$. Recall that we have

$$V(\lambda)^a \cong S(\mathfrak{n}_{\lambda}^-) / I_\lambda,$$

where I_λ is the annihilating ideal of v_λ . We know that $f_\alpha^{(\lambda, \alpha^\vee)+1}v_\lambda$ is zero in $V(\lambda)$ (see (1.4)). Hence $f_\alpha^{(\lambda, \alpha^\vee)+1}v_\lambda = 0$ in $V(\lambda)^a$. By the action of $U(\mathfrak{n}^+)$ on $V(\lambda)^a$ we obtain further relations. We will see that these relations are enough to rewrite every element as a linear combination of $f^{\mathbf{s}}v_\lambda$, $\mathbf{s} \in S(\lambda)$.

In our proof it is essential to have a Hasse diagram $H(\mathfrak{n}_\lambda^-)_{\mathfrak{g}}$ without k -chains. A Dyck path is defined as before to be the set of roots corresponding to a directed path in $H(\mathfrak{n}_\lambda^-)_{\mathfrak{g}}$.

Let \circ be the action of $U(\mathfrak{n}^+)$ on $S(\mathfrak{g})$ induced by the adjoint action of \mathfrak{n}^+ on \mathfrak{g} . Via the isomorphism $S(\mathfrak{n}^-) \cong S(\mathfrak{g})/S(\mathfrak{g})(S_+(\mathfrak{n}^+ \oplus \mathfrak{h}))$ we obtain an action on $S(\mathfrak{n}^-)$, where $S_+(\mathfrak{n}^+ \oplus \mathfrak{h}) \subset S(\mathfrak{n}^+ \oplus \mathfrak{h})$ is the augmentation ideal. By

$$S(\mathfrak{n}_\lambda^-) \cong S(\mathfrak{n}^-)/S(\mathfrak{n}^-)(\text{span}\{f_\beta \mid \beta \in \Delta_+ \setminus \Delta_+^\lambda\})$$

we get an action on $S(\mathfrak{n}_\lambda^-)$. We denote this action again by \circ . Since the action of $U(\mathfrak{n}^+)$ on $V(\lambda)^a$ is induced by the action of $U(\mathfrak{n}^+)$ on $V(\lambda)$ (which is again induced by the adjoint action), we obtain that for all $e \in U(\mathfrak{n}^+)$, $f \in S(\mathfrak{n}_\lambda^-)$

$$(3.1) \quad e(fv_\lambda) = (e \circ f)v_\lambda,$$

holds. Therefore we can restrict our further discussion on the $U(\mathfrak{n}^+)$ -module $S(\mathfrak{n}_\lambda^-)$. Equation (3.1) and $U(\mathfrak{n}^+)(fv_\lambda) = U(\mathfrak{n}^+)(0) = \{0\}$ for all $f \in I_\lambda$ imply that I_λ is stable under \circ . Furthermore, by Remark 1.1.4 the total degree of a monomial in $S(\mathfrak{n}_\lambda^-)/I_\lambda$ is invariant or it is zero under \circ . We denote as before $\Delta_+^\lambda = \{\beta_1, \dots, \beta_N\}$ and use the same total order \prec on the multi-exponents (resp. monomials) as defined in Section 1, which is induced by $\beta_1 \prec \beta_2 \prec \dots \prec \beta_N$.

We define differential operators; for $\alpha, \beta \in \Delta_+$ let

$$\partial_\alpha f_\beta := \begin{cases} f_{\beta-\alpha}, & \text{if } \beta - \alpha \in \Delta_+^\lambda \\ 0, & \text{else.} \end{cases}$$

The operators satisfy

$$\partial_\alpha f_\beta = c_{\alpha, \beta} [e_\alpha, f_\beta],$$

for constants $c_{\alpha, \beta} \in \mathbb{C}$. So instead of using \circ we can work with these differential operators. We point out that we need the differential operators for arbitrary roots in Δ_+ .

Remark 3.1.1. *Here we want to illustrate the problem which occurs if we allow k -chains in our Hasse diagram. Let $\gamma \prec \beta \prec \delta$ the roots of a k -chain $\gamma \xrightarrow{k} \beta \xrightarrow{k} \delta$ and consider for $\ell \geq 2$:*

$$(3.2) \quad \partial_k^2 f_\gamma^\ell = \partial_k(\ell f_\beta^1 f_\gamma^{\ell-1}) = \underbrace{c_0 \ell f_\delta^1 f_\beta^0 f_\gamma^{\ell-1}}_{\text{maximal monomial}} + c_1 \ell(\ell-1) f_\beta^2 f_\gamma^{\ell-2},$$

with $c_0 = c_{\gamma, \alpha_k} c_{\beta, \alpha_k}$ and $c_1 = c_{\gamma, \alpha_k}^2$ where $c_{\gamma, \alpha_k}, c_{\beta, \alpha_k}$ are the structure constants corresponding to $[e_{\alpha_k}, f_\beta]$ and $[e_{\alpha_k}, f_\gamma]$ respectively. So it is more involved to find a relation which contains β and δ .

The next Lemma describes the action of the differential operators and gives an explicit characterization of the maximal monomial of $\partial_\nu f^{\mathbf{s}}$ for certain $\nu \in \Delta_+$ and $\mathbf{s} \in \mathbb{Z}_{\geq 0}^N$.

Lemma 3.1.2. *Assume $H(\mathfrak{n}_\lambda^-)_{\mathfrak{g}}$ has no k -chains.*

(i) *Let $\mathbf{p} = \{\beta_{i_1}, \dots, \beta_{i_r}\} \in D_\lambda$ with $\beta_{i_1} \prec \dots \prec \beta_{i_r}$ and $\nu \in \Delta_+$. Further let*

$\beta_{i_k}, k \leq r$ be maximal such that $\partial_\nu f_{\beta_{i_k}} \neq 0$. Let $\mathbf{s} \in \mathbb{Z}_{\geq 0}^N$ be a multi-exponent supported on \mathbf{p} , i.e. $s_\beta = 0$ for $\beta \notin \mathbf{p}$. Then the maximal monomial in $\partial_\nu^l f^{\mathbf{s}} = \partial_\nu^l (f_{i_1}^{s_1} \cdots f_{i_r}^{s_r})$, $l \leq s_k$, is given by

$$f_{i_1}^{s_1} \cdots f_{i_{k-1}}^{s_{k-1}} (f_{i_k - \nu}^l f_{i_k}^{s_k - l}) f_{i_{k+1}}^{s_{k+1}} \cdots f_{i_r}^{s_r}.$$

(ii) Let $\sum_{\mathbf{u} \in \mathbb{Z}_{\geq 0}^N} c_{\mathbf{u}} f^{\mathbf{u}} \in S(\mathfrak{n}^-)$ and $\nu \in \Delta_+$. Let $\mathbf{h} = \max\{\mathbf{u} \mid \partial_\nu f^{\mathbf{u}} \neq 0, c_{\mathbf{u}} \neq 0\}$. Further let $\beta_k = \max\{\beta \mid f_\beta \text{ is a factor of } f^{\mathbf{u}}, \partial_\nu f_\beta \neq 0, c_{\mathbf{u}} \neq 0\}$ and assume $h_{\beta_k} > 0$. Then for $l \leq h_{\beta_k}$ the maximal monomial in

$$\partial_\nu^l \sum_{\mathbf{u} \in \mathbb{Z}_{\geq 0}^N} c_{\mathbf{u}} f^{\mathbf{u}} = \sum_{\mathbf{u} \in \mathbb{Z}_{\geq 0}^N} c_{\mathbf{u}} \partial_\nu^l f^{\mathbf{u}}$$

appears in $\partial_\nu^l f^{\mathbf{h}}$.

Proof. (i) Assume we have two roots $\beta_i, \beta_j \in \Delta_+^\lambda$ with $\beta_i \prec \beta_j$ and $\beta_i - \nu$ and $\beta_j - \nu$ are again roots in Δ_+^λ . For $\beta_{i_l} - \nu \notin \Delta_+^\lambda$ we have $\partial_\nu f_{\beta_{i_l}} = 0$, so we do not need to consider such roots $\beta_{i_l} \in \Delta_+^\lambda$. So in order to prove (i), because our monomial order is lexicographic, it is sufficient to show that

$$(3.3) \quad \beta_i \prec \beta_j \Rightarrow \beta_i - \nu \prec \beta_j - \nu.$$

If $\beta_i > \beta_j$ with respect to the standard partial order we have $\beta_i - \nu > \beta_j - \nu$ and therefore $\beta_i - \nu \prec \beta_j - \nu$, by the choice of the total order (1.6) on Δ_+^λ .

If the roots are not comparable with respect to the standard partial order, the second step is to compare the heights of the roots. So if $\text{ht}(\beta_i) > \text{ht}(\beta_j)$ then $\text{ht}(\beta_i - \nu) > \text{ht}(\beta_j - \nu)$ and again $\beta_i - \nu \prec \beta_j - \nu$.

If $\text{ht}(\beta_i) = \text{ht}(\beta_j)$, we have to consider $\beta_i = (s_1, \dots, s_n)$ and $\beta_j = (t_1, \dots, t_n)$ in terms of the fixed basis of the simple roots (see Remark 1.1.3). Then there is a $1 \leq k \leq n$, such that $s_k > t_k$ and $s_i = t_i$ for all $1 \leq i < k$. Let $\nu = (u_1, \dots, u_n)$, then $\beta_i - \nu = (s_1 - u_1, \dots, s_n - u_n)$ is lexicographically greater than $\beta_j - \nu = (t_1 - u_1, \dots, t_n - u_n)$. Thus $\beta_i - \nu \prec \beta_j - \nu$ and (3.3) holds.

(ii) We only have to consider the multi-exponents $\mathbf{s} \in \mathbb{Z}_{\geq 0}^N$ such that $\partial_\nu f^{\mathbf{s}} \neq 0$. Now let \mathbf{t} be the maximal multi-exponent with this property and let $l \leq t_{\beta_k}$. Then we have $\partial_\nu^l f^{\mathbf{t}} \neq 0$ and by (i) the maximal monomial appearing in $\partial_\nu^l f^{\mathbf{t}}$ is

$$(3.4) \quad f_{\beta_k - \nu}^l f_{\beta_k}^{t_{\beta_k} - l} \prod_{\substack{\beta \in \Delta_+^\lambda, \beta \neq \beta_k \\ \beta \neq \beta_k - \nu}} f_\beta^{t_\beta}.$$

The observation (3.3) tells us that $f_{\beta_k - \nu} = \max\{f_{\beta - \nu} \mid \partial_\nu f_\beta \neq 0, s_\beta > 0\}$. So by the choice of \mathbf{t} and because our order is lexicographic, the element (3.4) is the maximal monomial in $\sum_{\mathbf{s} \in \mathbb{Z}_{\geq 0}^N} c_{\mathbf{s}} \partial_\nu^l f^{\mathbf{s}}$. \square

Proposition 3.1.3. *Assume $H(\mathfrak{n}_\lambda^-)_\mathfrak{g}$ has no k -chains and let $\mathbf{p} \in D_\lambda$ be a Dyck path, $\mathbf{s} \in \mathbb{Z}_{\geq 0}^N$ be a multi-exponent supported on \mathbf{p} . Suppose further $\langle \lambda, \theta^\vee \rangle = m$ and $\sum_{\alpha \in \mathbf{p}} s_\alpha > m$. Then there exist constants $c_{\mathbf{t}} \in \mathbb{C}$, $\mathbf{t} \in \mathbb{Z}_{\geq 0}^N$ such that:*

$$(3.5) \quad f^{\mathbf{s}} + \sum_{\mathbf{t} \prec \mathbf{s}} c_{\mathbf{t}} f^{\mathbf{t}} \in I_\lambda.$$

We follow an idea of [FFoL11a, FFoL11b] who showed a similar statement in the cases \mathfrak{sl}_n and \mathfrak{sp}_n for arbitrary dominant integral weights.

Proof. Let $\mathbf{p} = \{\tau_0, \tau_1, \dots, \tau_r\} \in D_\lambda$ be an arbitrary Dyck path. By construction we have for $1 \leq i \leq r$: $\tau_{i-1} \prec \tau_i$. Because $\sum_{i=0}^r s_{\tau_i} > m$ we have

$$f_\theta^{s_{\tau_0} + \dots + s_{\tau_r}} \in I_\lambda.$$

By the construction of the Hasse diagram there is a Dyck path $\mathbf{p}' \in D_\lambda$ with $\mathbf{p} \subset \mathbf{p}'$, such that there is no path \mathbf{p}'' with $\mathbf{p}' \subsetneq \mathbf{p}''$. Hence we can assume wlog

$$\mathbf{p} = \{\tau_0 = \theta, \tau_1, \dots, \tau_{r-1}, \tau_r = \beta_N\}.$$

Let $\nu_1, \dots, \nu_r \in \Delta_+$, with $\nu_i \neq \nu_{i+1}$ be the labels at the edges of \mathbf{p} . We consider $f_\theta^{s_{\tau_0} + \dots + s_{\tau_r}} \in I_\lambda$. Because I_λ is stable under \circ , we have for arbitrary $x_1, \dots, x_l \in \Delta_+$ and $f^{\mathbf{t}} \in I_\lambda$:

$$\partial_{x_1} \dots \partial_{x_l} f^{\mathbf{t}} \in I_\lambda.$$

We define

$$(3.6) \quad A := \partial_{\nu_r}^{s_{\tau_r}} \dots \partial_{\nu_2}^{s_{\tau_2} + \dots + s_{\tau_r}} \partial_{\nu_1}^{s_{\tau_1} + \dots + s_{\tau_r}} f_\theta^{s_{\tau_0} + \dots + s_{\tau_r}} \in I_\lambda.$$

Claim: There exist constants $c_{\mathbf{s}} \neq 0, c_{\mathbf{t}} \in \mathbb{C}, \mathbf{t} \in \mathbb{Z}_{\geq 0}^N$ with $\mathbf{t} \prec \mathbf{s}$, such that:

$$(3.7) \quad A = c_{\mathbf{s}} f^{\mathbf{s}} + \sum_{\mathbf{t} \prec \mathbf{s}} c_{\mathbf{t}} f^{\mathbf{t}} \in I_\lambda$$

If the claim holds the Proposition is proven.

Proof of the claim. Now we need the explicit description of the Dyck paths given by the Hasse diagram. Above we defined ν_1 to be the label at the edge $\theta \xrightarrow{\nu_1} \tau_1$ in $H(\mathfrak{n}_\lambda^-)_{\mathfrak{g}}$. Because we assumed that $H(\mathfrak{n}_\lambda^-)_{\mathfrak{g}}$ has no ν_1 -chains of length 2, there is no edge labeled by ν_1 starting in the vertex $\theta - \nu_1 = \tau_1$. That means $\partial_{\nu_1} f_{\theta - \nu_1} = 0$. Therefore we obtain

$$\partial_{\nu_1}^{s_{\tau_1} + \dots + s_{\tau_r}} f_\theta^{s_{\tau_0} + \dots + s_{\tau_r}} = a_0 f_\theta^{s_{\tau_0}} f_{\theta - \nu_1}^{s_{\tau_1} + \dots + s_{\tau_r}} \in I_\lambda$$

for some constant $a_0 \in \mathbb{C} \setminus \{0\}$. Now ν_2 is the label at the edge between the vertices τ_1 and τ_2 . Again there is no ν_2 -chain in $H(\mathfrak{n}_\lambda^-)_{\mathfrak{g}}$, so $\partial_{\nu_2} f_{\theta - \nu_1 - \nu_2} = 0$ and $\partial_{\nu_2} f_{\theta - \nu_2} = 0$, so we have for $k = \min\{s_{\tau_0}, s_{\tau_2} + \dots + s_{\tau_r}\}$, $b_q \in \mathbb{C} \setminus \{0\}$:

$$(3.8) \quad \begin{aligned} & \partial_{\nu_2}^{s_{\tau_2} + \dots + s_{\tau_r}} a_0 f_\theta^{s_{\tau_0}} f_{\theta - \nu_1}^{s_{\tau_1} + \dots + s_{\tau_r}} = \\ & b_0 f_\theta^{s_{\tau_0}} f_{\theta - \nu_1}^{s_{\tau_1}} f_{\theta - \nu_1 - \nu_2}^{s_{\tau_2} + \dots + s_{\tau_r}} + \sum_{q=1}^k b_q f_\theta^{s_{\tau_0} - q} f_{\theta - \nu_1}^{s_{\tau_1} + q} f_{\theta - \nu_1 - \nu_2}^{s_{\tau_2} + \dots + s_{\tau_r} - q} f_{\theta - \nu_2}^q. \end{aligned}$$

For our purposes, we do not need to pay attention to the scalars unless they are zero. We also notice that the terms of the sum are only non-zero, if $\theta - \nu_2 \in \Delta_+^\lambda$.

The first part of Lemma 3.1.2 implies, that the monomial $f_\theta^{s_{\tau_0}} f_{\theta - \nu_1}^{s_{\tau_1}} f_{\theta - \nu_1 - \nu_2}^{s_{\tau_2} + \dots + s_{\tau_r}}$ is the largest (with respect to \prec) in (3.8), because $\theta \prec \theta - \nu_1 \prec \theta - \nu_1 - \nu_2$. By construction $\partial_{\nu_{i+1}} f_{\theta - \nu_1 - \nu_2 - \dots - \nu_i} \neq 0$, because $\theta - \nu_1 - \nu_2 - \dots - \nu_i - \nu_{i+1}$ is an element of Δ_+^λ , for $i < r$. So the second statement of Lemma 3.1.2 implies that

the largest element is obtained by acting in each step on the largest root vector. To be more precise, we consider the following equations:

$$\begin{aligned}
& \partial_{\nu_r}^{s_{\tau_r}} \dots \partial_{\nu_2}^{s_{\tau_2} + \dots + s_{\tau_r}} \partial_{\nu_1}^{s_{\tau_1} + \dots + s_{\tau_r}} f_{\theta}^{s_{\tau_0} + \dots + s_{\tau_r}} = \\
& \quad a_0 \partial_{\nu_r}^{s_{\tau_r}} \dots \partial_{\nu_2}^{s_{\tau_2} + \dots + s_{\tau_r}} f_{\theta}^{s_{\tau_0}} f_{\theta-\nu_1}^{s_{\tau_1} + \dots + s_{\tau_r}} = \\
& \quad b_0 \partial_{\nu_r}^{s_{\tau_r}} \dots \partial_{\nu_3}^{s_{\tau_3} + \dots + s_{\tau_r}} f_{\theta}^{s_{\tau_0}} f_{\theta-\nu_1}^{s_{\tau_1}} f_{\theta-\nu_1-\nu_2}^{s_{\tau_2} + \dots + s_{\tau_r}} + \sum \text{smaller monomials} = \\
& \quad \vdots \\
& \quad b'_0 f_{\theta}^{s_{\tau_0}} f_{\theta-\nu_1}^{s_{\tau_1}} f_{\theta-\nu_1-\nu_2}^{s_{\tau_2}} \dots f_{\theta-\nu_1-\nu_2-\dots-\nu_r}^{s_{\tau_r}} + \sum \text{smaller monomials} \in I_{\lambda}.
\end{aligned}$$

for some $b'_0 \in \mathbb{C} \setminus \{0\}$. But the last term is exactly what we wanted to obtain, so for constants $c_{\mathbf{t}} \in \mathbb{C}$, $c_{\mathbf{s}} \in \mathbb{C} \setminus \{0\}$ we have by assumption that $s_{\alpha} = 0$ if $\alpha \notin \mathbf{p}$:

$$\begin{aligned}
& \partial_{\nu_r}^{s_{\tau_r}} \dots \partial_{\nu_2}^{s_{\tau_2} + \dots + s_{\tau_r}} \partial_{\nu_1}^{s_{\tau_1} + \dots + s_{\tau_r}} f_{\theta}^{s_{\tau_0} + \dots + s_{\tau_r}} = \\
& \quad c_{\mathbf{s}} f_{\theta}^{s_{\tau_0}} f_{\tau_1}^{s_{\tau_1}} f_{\tau_2}^{s_{\tau_2}} \dots f_{\tau_r}^{s_{\tau_r}} + \sum_{\mathbf{t} \prec \mathbf{s}} c_{\mathbf{t}} f^{\mathbf{t}} = \\
& \quad c_{\mathbf{s}} f^{\mathbf{s}} + \sum_{\mathbf{t} \prec \mathbf{s}} c_{\mathbf{t}} f^{\mathbf{t}} \in I_{\lambda}.
\end{aligned}$$

□

Theorem 3.1.4. *The set $\{f^{\mathbf{s}} v_{\lambda} \mid \mathbf{s} \in S(\lambda)\}$ spans the module $V(\lambda)^a$.*

Proof. Let $m \in \mathbb{Z}_{\geq 0}$ and $\mathbf{t} \in \mathbb{Z}_{\geq 0}^N$ with $\mathbf{t} \notin S(\lambda)$. That means there exists a Dyck path $\mathbf{p} \in D_{\lambda}$ such that $\sum_{\beta \in \mathbf{p}} t_{\beta} > m$. Define a new multi-exponent \mathbf{t}' by

$$t'_{\beta} := \begin{cases} t_{\beta}, & \text{if } \beta \in \mathbf{p}, \\ 0, & \text{else.} \end{cases}$$

Because of $\sum_{\beta \in \mathbf{p}} t'_{\beta} = \sum_{\beta \in \mathbf{p}} t_{\beta} > m$ we can apply Proposition 3.1.3 to \mathbf{t}' and get

$$f^{\mathbf{t}'} = \sum_{\mathbf{s}' \prec \mathbf{t}'} c_{\mathbf{s}'} f^{\mathbf{s}'} \in S(\mathfrak{n}_{\lambda}^-)/I_{\lambda},$$

for some $c_{\mathbf{s}'} \in \mathbb{C}$. Because the order of the factors of $f^{\mathbf{t}} \in S(\mathfrak{n}_{\lambda}^-)$ is arbitrary and since we have a monomial order, we get

$$(3.9) \quad f^{\mathbf{t}} = f^{\mathbf{t}'} \prod_{\beta \notin \mathbf{p}} f_{\beta}^{t_{\beta}} = \sum_{\mathbf{s} \prec \mathbf{t}} c_{\mathbf{s}} f^{\mathbf{s}} \in S(\mathfrak{n}_{\lambda}^-)/I_{\lambda},$$

where $c_{\mathbf{s}} = c_{\mathbf{s}'}$ and $f^{\mathbf{s}} = f^{\mathbf{s}'} \prod_{\beta \notin \mathbf{p}} f_{\beta}^{s_{\beta}}$. Equation (3.9) shows that we can express an arbitrary multi-exponent as a sum of strictly smaller multi-exponents. We repeat this procedure until all multi-exponents in the sum lie in $S(\lambda)$. There are only finitely many multi-exponents of a fixed degree and the degree is invariant or zero under the action \circ . So after a finite number of steps, we can express \mathbf{t} in terms of $\mathbf{r} \in S(\lambda)$ for some $c_{\mathbf{r}} \in \mathbb{C}$:

$$f^{\mathbf{t}} = \sum_{\mathbf{r} \in S(\lambda)} c_{\mathbf{r}} f^{\mathbf{r}} \in S(\mathfrak{n}_{\lambda}^-)/I_{\lambda}.$$

□

Corollary 3.1.5. *Fix for every $\mathbf{s} \in S(\lambda)$ an arbitrary ordering of the factors f_β in the product $\prod_{\beta>0} f_\beta^{s_\beta} \in S(\mathfrak{n}_\lambda^-)$. Let $f^{\mathbf{s}} = \prod_{\beta>0} f_\beta^{s_\beta} \in U(\mathfrak{n}^-)$ be the ordered product. Then the elements $f^{\mathbf{s}}v_\omega, \mathbf{s} \in S(\lambda)$ span the module $V(\lambda)$.*

Proof. Let $f^{\mathbf{t}}v_\lambda \in V(\lambda)$ with $\mathbf{t} \in \mathbb{Z}_{\geq}^N$ arbitrary. We consider $f^{\mathbf{t}}v_\lambda$ as an element in $V(\lambda)^a$. By Theorem 3.1.4 we get

$$f^{\mathbf{t}}v_\lambda = \sum_{\mathbf{s} \in S(\lambda)} c_{\mathbf{s}} f^{\mathbf{s}}v_\lambda \text{ in } V(\lambda)^a.$$

The ordering of the factors in a product in $S(\mathfrak{n}_\lambda^-)$ is irrelevant, so we can adjust the ordering of the factors to the fixed ordering and get an induced linear combination:

$$f^{\mathbf{t}}v_\lambda = \sum_{\mathbf{s} \in S(\lambda)} c_{\mathbf{s}} f^{\mathbf{s}}v_\lambda \text{ in } V(\lambda).$$

□

4. FFL BASIS OF $V(\omega)$

Throughout this section we refer to the definitions in Subsection 1.1. In this section we calculate explicit FFL bases of the highest weight modules $V(\omega)$, where ω occurs in Table 2. We will do this by giving characterizations of the co-chains $\bar{\mathbf{p}} \in \bar{D}_\omega$ (see (1.9)) and using the one-to-one correspondence between \bar{D}_ω and $S(\omega)$ (see Proposition 1.1.10).

The results of this section, i.e. $\mathbb{B}_\omega = \{f^{\mathbf{s}}v_\omega \mid \mathbf{s} \in S(\omega)\}$ is a FFL basis of $V(\omega)$, provide the start of an inductive procedure in the proof of Theorem 5.1.2. With Proposition 2.2.5 we will be able to give an explicit basis of $V(m\omega)$, $m \in \mathbb{Z}_{\geq 0}$, parametrized by the m -th Minkowski sum of $S(\omega)$.

4.1. Type A_n . Let \mathfrak{g} be a simple Lie algebra of type A_n with $n \geq 1$ and the associated Dynkin diagram

$$A_n \quad \circ_1 \text{---} \circ_2 \text{---} \circ_3 \text{---} \circ_4 \text{---} \dots \text{---} \circ_n$$

The highest root is of the form $\theta = \sum_{i=1}^n \alpha_i$. Since a Lie algebra \mathfrak{g} of type A_n is simply laced we have $\theta^\vee = \sum_{i=1}^n \alpha_i^\vee$ and so $\langle \omega, \theta^\vee \rangle = 1 \Leftrightarrow \omega \in \{\omega_k \mid 1 \leq k \leq n\}$. The positive roots of \mathfrak{g} are described by: $\Delta_+ = \{\alpha_{i,j} = \sum_{l=i}^j \alpha_l \mid 1 \leq i \leq j \leq n\}$. So for the roots corresponding to $\mathfrak{n}_{\omega_k}^-$ we have:

$$(4.1) \quad \Delta_+^{\omega_k} = \{\alpha_{i,j} \in \Delta_+ \mid 1 \leq i \leq k \leq j \leq n\} \subset \Delta_+.$$

Before we define the total order on $\Delta_+^{\omega_k}$, we define a total order on Δ_+ :

$$\begin{aligned} \beta_1 &= \alpha_{1,n}, \\ \beta_2 &= \alpha_{2,n}, \quad \beta_3 = \alpha_{1,n-1}, \\ \beta_4 &= \alpha_{3,n}, \quad \beta_5 = \alpha_{2,n-1}, \quad \beta_6 = \alpha_{1,n-2}, \\ &\dots, \end{aligned}$$

$$\beta_{n(n-1)/2+1} = \alpha_n, \quad \beta_{n(n-1)/2+2} = \alpha_{n-1}, \dots, \quad \beta_{n(n+1)/2} = \alpha_1.$$

Now we delete every root $\beta_i \in \Delta_+ \setminus \Delta_+^{\omega_k}$ and relabel the remaining roots. For an example of this procedure see Appendix, Figure 2 and Example 1.1.6. In the following it is more convenient to use the description $\alpha_{i,j}$ instead of β_k . First we give a characterization of the co-chains $\bar{\mathbf{p}} \in \bar{D}_{\omega_k} \subset \mathcal{P}(\Delta_+^{\omega_k})$.

Proposition 4.1.1. *Let be $\bar{\mathbf{p}} = \{\alpha_{i_1, j_1}, \dots, \alpha_{i_s, j_s}\} \in \mathcal{P}(\Delta_+^{\omega_k})$ arbitrary, then:*

$$(4.2) \quad \bar{\mathbf{p}} \in \bar{D}_{\omega_k} \Leftrightarrow \forall \alpha_{i_l, j_l}, \alpha_{i_m, j_m} \in \bar{\mathbf{p}}, i_l \leq i_m : i_l < i_m \leq k \leq j_l < j_m.$$

Further we have: $\bar{\mathbf{p}} \in \bar{D}_{\omega_k} \Rightarrow s \leq \min\{k, n+1-k\}$.

Proof. First we prove (4.2): “ \Leftarrow ”: Let $\bar{\mathbf{p}} = \{\alpha_{i_1, j_1}, \dots, \alpha_{i_s, j_s}\} \in \mathcal{P}(\Delta_+^{\omega_k})$ be an element with the properties of the right-hand side (rhs) of (4.2). Let $\alpha_{i_l, j_l}, \alpha_{i_m, j_m} \in \bar{\mathbf{p}}$, with $i_l < i_m$. Consider now:

$$\alpha_{i_l, j_l} - \alpha_{i_m, j_m} = \sum_{r=i_l}^{j_l} \alpha_r - \sum_{r=i_m}^{j_m} \alpha_r = \sum_{r=i_l}^{i_m-1} \alpha_r - \sum_{r=j_l+1}^{j_m} \alpha_r.$$

Since $j_l < j_m$ holds, Remark 1.1.8 implies that there is no Dyck path $\mathbf{q} \in D_{\omega_k}$ such that α_{i_m, j_m} and α_{i_l, j_l} are contained in \mathbf{q} .

“ \Rightarrow ”: Let be $\bar{\mathbf{p}} \in \bar{D}_{\omega_k}$ and $\alpha_{i_l, j_l}, \alpha_{i_m, j_m} \in \bar{\mathbf{p}}$ with $\alpha_{i_l, j_l} \neq \alpha_{i_m, j_m}$. Further we have $i_l \leq j_l, i_m \leq j_m$. Assume wlog $i_m = j_m$, then $\alpha_{i_m, j_m} = \alpha_k$ and $i_l < j_l$. Hence

$$\alpha_{i_l, j_l} - \alpha_k = \sum_{r=i_l}^{k-1} \alpha_r + \sum_{r=k+1}^{j_l} \alpha_r,$$

which is a contradiction to $\bar{\mathbf{p}} \in \bar{D}_{\omega_k}$ by Remark 1.1.8. So $i_l < j_l, i_m < j_m$ and we assume wlog $i_l \leq i_m$.

1. Step: $i_l = i_m =: y$. Set $x = \min\{j_l, j_m\}$ and $\bar{x} = \max\{j_l, j_m\}$:

$$\alpha_{y, \bar{x}} - \alpha_{y, x} = \sum_{r=y}^{\bar{x}} \alpha_r - \sum_{r=y}^x \alpha_r = \sum_{r=x+1}^{\bar{x}} \alpha_r.$$

Again this contradicts to $\bar{\mathbf{p}} \in \bar{D}_{\omega_k}$. Hence we have: $i_l < i_m$.

2. Step: $(i_l < i_m) \wedge (j_l = j_m =: x)$:

$$\alpha_{i_l, x} - \alpha_{i_m, x} = \sum_{r=i_l}^x \alpha_r - \sum_{r=i_m}^x \alpha_r = \sum_{r=i_l}^{i_m-1} \alpha_r.$$

We conclude: $j_l \neq j_m$.

3. Step: $(i_l < i_m < j_m) \wedge (i_l < j_l)$. So there are three possible cases:

(a) $i_l < j_l < i_m < j_m$, (b) $i_l < i_m < j_l < j_m$ and (c) $i_l < i_m < j_m < j_l$.

The case (a) can not occur because $k \leq j_l < i_m \leq k$ is a contradiction. So let us assume $\alpha_{i_l, j_l}, \alpha_{i_m, j_m}$ satisfy the case (c), then we have:

$$\alpha_{i_l, j_l} - \alpha_{i_m, j_m} = \sum_{r=i_l}^{j_l} \alpha_r - \sum_{r=i_m}^{j_m} \alpha_r = \sum_{r=i_l}^{i_m-1} \alpha_r + \sum_{r=j_m}^{j_l} \alpha_r.$$

Finally we conclude that for two arbitrary roots $\alpha_{i_l, j_l}, \alpha_{i_m, j_m} \in \bar{\mathbf{p}} \in \bar{D}_{\omega_k}$ with $i_l \leq i_m$ we have: $i_l < i_m < j_l < j_m$.

It remains to show that the cardinality s of $\bar{\mathbf{p}}$ is bounded by $\min\{k, n+1-k\}$:

1. Case: $\min\{k, n+1-k\} = k$. Let $\alpha_{i_r, j_r} \in \bar{\mathbf{p}}$ be an arbitrary root in $\bar{\mathbf{p}}$. Then we know from (4.1) $1 \leq i_r \leq k$. But we also know that for any two roots $\alpha_{i_l, j_l}, \alpha_{i_m, j_m} \in \bar{\mathbf{p}}$ we have $i_l \neq i_m$. So there are at most k different roots in $\bar{\mathbf{p}}$.

2. Case: $\min\{k, n+1-k\} = n+1-k$. For two roots $\alpha_{i_l, j_l}, \alpha_{i_m, j_m} \in \bar{\mathfrak{p}}$ we have $j_l \neq j_m$ and $k \leq j_l, j_m \leq n$. So the number of different roots in $\bar{\mathfrak{p}}$ is bounded by $n+1-k$.

Finally we conclude: $|\bar{\mathfrak{p}}| = s \leq \min\{k, n+1-k\}$. \square

Remark 4.1.2. Let $\bar{\mathfrak{p}} = \{\alpha_{i_1, j_1}, \dots, \alpha_{i_s, j_s}\} \in \bar{D}_{\omega_k}$ then (4.2) implies

$$i_1 < i_2 < \dots < i_s \leq k \leq j_1 < j_2 < \dots < j_s.$$

Assume wlog $k = j_1 = j_2$, then there is Dyck path containing α_{i_1, j_1} and α_{i_2, j_2} , because $\alpha_{i_1, j_1} - \alpha_{i_2, j_2} = \alpha_{i_1, i_2-1} \in \Delta_+$.

Because of Corollary 3.1.5 we know that the elements $\{f^{\mathfrak{s}}v_{\omega_k} \mid \mathfrak{s} \in S(\omega_k)\}$ span $V(\omega_k)$ and by Proposition 1.1.10 there is a bijection between $S(\omega_k)$ and \bar{D}_{ω_k} . We want to show that these elements are linear independent. To achieve that we will show that $|\bar{D}_{\omega_k}| = \dim V(\omega_k)$. To be more explicit:

Proposition 4.1.3. For all $1 \leq k \leq n$ we have: $|\bar{D}_{\omega_k}| = \dim V(\omega_k) = \binom{n+1}{k}$.

Proof. Let $V(\omega_1)$ be the vector representation with basis $\{e_1, e_2, \dots, e_{n+1}\}$. Then $\wedge^k V(\omega_1)$ is a $U(\mathfrak{g})$ -representation with $v_{\omega_k} = e_1 \wedge e_2 \wedge \dots \wedge e_k$:

$$(4.3) \quad f_{\alpha_{i_1, j_1}} v_{\omega_k} = e_1 \wedge \dots \wedge e_{i_1-1} \wedge e_{j_1+1} \wedge e_{i_1+1} \wedge \dots \wedge e_k,$$

and we have $\wedge^k V(\omega_1) \cong V(\omega_k)$. We define $f_{\bar{\mathfrak{p}}} v_{\omega_k} := f_{\alpha_{i_1, j_1}} f_{\alpha_{i_2, j_2}} \dots f_{\alpha_{i_m, j_m}} v_{\omega_k}$ for $\bar{\mathfrak{p}} = \{\alpha_{i_1, j_1}, \alpha_{i_2, j_2}, \dots, \alpha_{i_m, j_m}\} \in \bar{D}_{\omega_k}$ and claim that the set $\{f_{\bar{\mathfrak{p}}} v_{\omega_k} \mid \bar{\mathfrak{p}} \in \bar{D}_{\omega_k}\}$ is linear independent in $\wedge^k V(\omega_1)$. If the claim holds we have $|\bar{D}_{\omega_k}| \leq \dim V(\omega_k)$ and with Corollary 3.1.5 we conclude that $|\bar{D}_{\omega_k}| = \dim V(\omega_k) = \binom{n+1}{k}$.

Proof of the claim. Assume we have $\bar{\mathfrak{p}}_1 = \{\alpha_{i_1, j_1}, \alpha_{i_2, j_2}, \dots, \alpha_{i_m, j_m}\}$ and $\bar{\mathfrak{p}}_2 = \{\alpha_{s_1, t_1}, \alpha_{s_2, t_2}, \dots, \alpha_{s_\ell, t_\ell}\}$ in \bar{D}_{ω_k} with linear dependent images under the action (4.3), i. e. $f_{\bar{\mathfrak{p}}_1} v_{\omega_k} = \pm f_{\bar{\mathfrak{p}}_2} v_{\omega_k}$. Then we have $m = \ell$, $\{j_1, \dots, j_m\} = \{t_1, \dots, t_\ell\}$ and we can assume wlog: $m = k = \ell$. Hence: $f_{\bar{\mathfrak{p}}_1} v_{\omega_k} = e_{j_1} \wedge \dots \wedge e_{j_m} = \pm f_{\bar{\mathfrak{p}}_2} v_{\omega_k}$, with Remark 4.1.2 we conclude $\bar{\mathfrak{p}}_1 = \bar{\mathfrak{p}}_2$. \square

Example 4.1.4. The non-redundant inequalities of the polytope $P(m\omega_3)$ in the case $\mathfrak{g} = \mathfrak{sl}_5$ are:

$$P(m\omega_3) = \left\{ \mathbf{x} \in \mathbb{R}_{\geq 0}^6 \mid \begin{array}{l} x_1 + x_2 + x_4 + x_6 \leq m \\ x_1 + x_2 + x_5 + x_6 \leq m \\ x_1 + x_3 + x_5 + x_6 \leq m \end{array} \right\}.$$

Example 1.1.6 shows the corresponding Hasse diagram $H(\mathfrak{n}_{\omega_3}^-)_{\mathfrak{sl}_5}$.

Proposition 4.1.3 implies immediately for $1 \leq k \leq n$:

Proposition 4.1.5. The vectors $f^{\mathfrak{s}}v_{\omega_k}, \mathfrak{s} \in S(\omega_k)$ are a FFL basis of $V(\omega_k)$. \square

4.2. Type B_n . Let \mathfrak{g} be a simple Lie algebra of type $B_n, n \geq 2$ with associated Dynkin diagram

$$B_n \quad \circ_1 \text{---} \circ_2 \text{---} \dots \text{---} \circ_{n-2} \text{---} \circ_{n-1} \text{---} \circ_n$$

The highest root for a Lie algebra of type B_n is of the form $\theta = \alpha_1 + 2 \sum_{i=2}^n \alpha_i$. So we have $\theta^\vee = \alpha_1^\vee + 2 \sum_{i=2}^{n-1} \alpha_i^\vee + \alpha_n^\vee$ and $\langle \omega, \theta^\vee \rangle = 1 \Leftrightarrow \omega \in \{\omega_1, \omega_n\}$.

First we consider the case $\omega = \omega_1$. We want to consider the case B_2, ω_1 separately. Because there are not enough roots, this case does not fit in our general

description of \mathbf{B}_n, w_1 . We claim that the following polytope parametrizes a FFL basis of $V(m\omega_1), m \in \mathbb{Z}_{\geq 0}$:

$$P(m\omega_1) = \left\{ \mathbf{x} \in \mathbb{R}_{\geq 0}^3 \mid \begin{array}{l} x_2 + x_1 \leq m \\ x_2 + x_3 \leq m \end{array} \right\}.$$

We fix $\beta_1 = (2, 1), \beta_2 = (1, 1), \beta_3 = (1, 0)$ and the order $\beta_2 \prec \beta_1 \prec \beta_3$. Then with Proposition 2.2.5 it is immediate that this polytope is normal. The following actions of the differential operators imply the spanning property in the sense of Section 3 Proposition 3.1.3.

$$\begin{aligned} \partial_{\alpha_2}^{s_1} f_1^{s_1+s_2} &= c_0 f_1^{s_1} f_2^{s_2} + \text{smaller terms} \in I_\lambda \\ \partial_{\alpha_1}^{s_2+2s_3} f_1^{s_2+s_3} &= c_1 f_2^{s_2} f_3^{s_3} + \text{smaller terms} \in I_\lambda, \quad c_i \in \mathbb{C} \setminus \{0\}. \end{aligned}$$

We conclude that $\{f^{\mathbf{s}} v_{\omega_1} \mid \mathbf{s} \in S(m\omega_1)\} = \{v_{\omega_1}, f_1 v_{\omega_1}, f_2 v_{\omega_1}, f_3 v_{\omega_1}, f_1 f_3 v_{\omega_1}, \}$ is a spanning set of $V(\omega_1)$.

Now we consider the case $n \geq 3$. If we construct $H(\mathfrak{n}_{\omega_1}^-)_{\mathfrak{g}}$ as in Section 1 we get a n -chain of length 2. Therefore we choose a new order on the roots and change our Hasse diagram slightly to obtain a diagram without k -chains of length 2. We illustrate this procedure for \mathfrak{g} of type \mathbf{B}_3 . Then the roots $\Delta_+^{\omega_1}$ are given by

$$\boxed{\beta_1 = (1, 2, 2) \mid \beta_2 = (1, 1, 2) \mid \beta_3 = (1, 1, 1) \mid \beta_4 = (1, 1, 0) \mid \beta_5 = (1, 0, 0)}$$

We choose a new order

$$\beta_1 \prec \beta_2 \prec \beta_4 \prec \beta_5 \prec \beta_3,$$

and change the Hasse diagram

$$\beta_1 \xrightarrow{2} \beta_2 \xrightarrow{3} \beta_3 \xrightarrow{3} \beta_4 \xrightarrow{2} \beta_5 \quad \rightsquigarrow \quad \begin{array}{ccc} & \beta_2 & \\ & \nearrow 2 & \searrow 012 \\ \beta_1 & \xrightarrow{011} \beta_3 & \beta_5. \\ & \searrow 012 & \nearrow 2 \\ & \beta_4 & \end{array}$$

First we check, if the new diagram has no k -chains. The first edge is labeled by $\alpha_2 + \alpha_3 = 011$ and we have $\beta_3 - (\alpha_2 + \alpha_3) = \beta_5$. If we have a monomial $f_1^{k_1} f_3^{k_2} \in S(\mathfrak{n}_{\omega_1}^-), k_1, k_2 \geq 1$ and we act by $\partial_{\alpha_2+\alpha_3}$ we get:

$$c_0 f_1^{k_1-1} f_3^{k_2+1} + c_1 f_1^{k_1} f_3^{k_2-1} f_5, \quad c_i \in \mathbb{C}.$$

By the change of order β_3 is larger than β_5 and so $f_1^{k_1-1} f_3^{k_2+1} \succ f_1^{k_1} f_3^{k_2-1} f_5$. Therefore we can neglect the edge between β_3 and β_5 .

Now we consider $\partial_{\alpha_2}^{k_3} f_1^{k_1} f_3^{k_2}$. Because of $\partial_{\alpha_2} f_3, \partial_{\alpha_2} f_2 = 0$ we get $f_1^{k_1-k_3} f_3^{k_2} f_2^{k_3}$, for $k_3 \leq k_1$. So instead of drawing an edge directly from β_1 to β_2 , we can draw an edge, labeled by 2, from β_3 to β_2 . Similar, because of $\beta_1 - \alpha_2 - 2\alpha_3 = \beta_4$, we can draw an edge labeled by 012 from β_3 to β_4 . The other edges do not cause any problems.

The second step is to show that the paths in the new diagram, define the actions by differential operators and the corresponding maximal elements like in Section 3 Proposition 3.1.3. By the choice of order we get the following equalities:

$$\begin{aligned} \partial_{\alpha_2+2\alpha_3}^{s_5} \partial_2^{s_2} \partial_{\alpha_2+\alpha_3}^{s_3} f_1^{s_1+s_3+s_2+s_5} &= c_0 f_1^{s_1} f_3^{s_3} f_2^{s_2} f_5^{s_5} + \text{smaller terms} \in I_\lambda \\ \partial_{\alpha_2}^{s_5} \partial_{\alpha_2+2\alpha_3}^{s_4} \partial_{\alpha_2+\alpha_3}^{s_3} f_1^{s_1+s_3+s_4+s_5} &= c_1 f_1^{s_1} f_3^{s_3} f_4^{s_4} f_5^{s_5} + \text{smaller terms} \in I_\lambda, \end{aligned}$$

with $c_i \in \mathbb{C} \setminus \{0\}$. In the general case, for arbitrary $n > 3$, we have $N = 2n - 1$. Let $r := \lceil N/2 \rceil$, then $\Delta_+^{\omega_1}$ is given by:

| | | | |
|---------------------------------|--|---------|-------------------------------------|
| $\beta_1 = (1, 2, 2, \dots, 2)$ | $\beta_2 = (1, 1, 2, \dots, 2, 2)$ | \dots | $\beta_{r-1} = (1, 1, \dots, 1, 2)$ |
| $\beta_r = (1, 1, 1, \dots, 1)$ | $\beta_{r+1} = (1, 1, 1, \dots, 1, 0)$ | \dots | $\beta_N = (1, 0, \dots, 0, 0)$ |

Then the only n -chain has the following form $\beta_{r-1} \xrightarrow{n} \beta_r \xrightarrow{n} \beta_{r+1}$. We change the order from $\beta_1 \prec \beta_2 \prec \dots \prec \beta_N$ to

$$(4.4) \quad \beta_1 \prec \beta_2 \prec \dots \prec \beta_{r-1} \prec \beta_{r+2} \preceq \dots \preceq \beta_{N-1} \preceq \beta_{r+1} \prec \beta_N \prec \beta_r.$$

The modifications of the diagram are similar to them in the case of \mathbf{B}_3 , so the Hasse diagram for a Lie algebra of type \mathbf{B}_n has the following shape

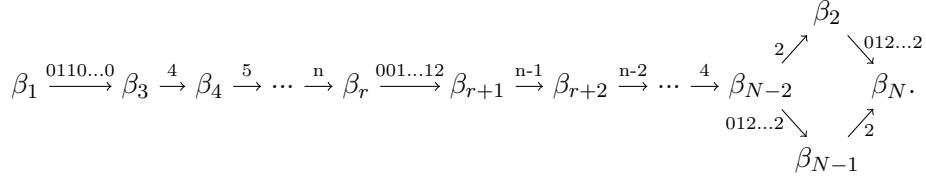

Associated to the diagrams we get the following polytope for $m \in \mathbb{Z}_{\geq 0}$:

$$(4.5) \quad P(m\omega_1) = \left\{ \mathbf{x} \in \mathbb{R}_{\geq 0}^N \mid \begin{array}{l} x_1 + x_2 + \dots + x_{N-2} + x_N \leq m \\ x_1 + x_3 + \dots + x_{N-1} + x_N \leq m \end{array} \right\}.$$

By Section 3, Corollary 3.1.5 the elements

$$v_{\omega_1}, f_1 v_{\omega_1}, f_2 v_{\omega_1}, \dots, f_N v_{\omega_1}, f_2 f_{N-1} v_{\omega_1}$$

span $V(\omega)$ and with [Car05, p. 276] we have $\dim V(\omega_1) = 2n + 1$.

Proposition 4.2.1. *The vectors $f^{\mathbf{s}} v_{\omega_1}, \mathbf{s} \in S(\omega_1)$ are a FFL basis of $V(\omega_1)$. \square*

Proof. The previous observations imply that $\{f^{\mathbf{s}} v_{\omega_1}, \mathbf{s} \in S(\omega_1)\}$ is a basis of $V(\omega_1)$. So it remains to show that $P(\omega_1)$ is a normal polytope.

Because we changed the Hasse diagram we have to change the order of the roots to apply Section 2. One possible new order is given by:

$$\beta_1 \prec \beta_3 \prec \beta_4 \prec \dots \prec \beta_{N-2} \prec \beta_2 \prec \beta_{N-1} \prec \beta_N.$$

Using this order we see immediately that $P(\omega_1)$ is a normal polytope. \square

Now we consider the case $\omega = \omega_n$. In the following it will be again convenient to describe the roots and fundamental weights of \mathbf{B}_n in terms of an orthogonal basis:

$$(4.6) \quad \Delta_+^{\omega_n} = \{\varepsilon_{i,j} = \varepsilon_i + \varepsilon_j \mid 1 \leq i < j \leq n\} \cup \{\varepsilon_k \mid 1 \leq k \leq n\}.$$

The total order on $\Delta_+^{\omega_n}$ is obtained by considering the Hasse diagram. We begin with $\beta_1 = \theta$ on the top and then labeling from left to right with increasing label on each level of the Hasse diagram, which correspond to the height of the roots in $\Delta_+^{\omega_n}$. For a concrete example see Figure 3 in the Appendix. The corresponding polytope is defined as usual, see Table 3 for an example. The elements of $\Delta_+^{\omega_n}$ correspond to $\varepsilon_{i,j} = \sum_{r=i}^{j-1} \alpha_r + 2 \sum_{r=j}^n \alpha_r$ and $\varepsilon_k = \sum_{r=k}^n \alpha_r$. The highest weight of $V(\omega_n)$ has the description $\omega_n = \frac{1}{2} \sum_{r=1}^n \varepsilon_r$. Further the lowest weight is $-\omega_n = -\frac{1}{2} \sum_{r=1}^n \varepsilon_r$. With this observation, the fact that ω_n is minuscule and

(4.6) we see that

$$(4.7) \quad \mathbb{B}_{V(\omega_n)} = \left\{ f_\alpha v_{\omega_n} \mid \alpha = \frac{1}{2} \sum_{r=1}^n l_r \varepsilon_r, l_r \in \{-1, 1\}, \forall 1 \leq r \leq n \right\} \subset V(\omega_n)$$

is a basis. We note that $|\mathbb{B}_{V(\omega_n)}| = 2^n = \dim V(\omega_n)$.

Remark 4.2.2. For an arbitrary element $\bar{\mathbf{p}} \in \overline{D}_{\omega_n}^{\mathbf{B}_n}$ we have at most one root of the form $\varepsilon_k \in \bar{\mathbf{p}}$, because if there are $\varepsilon_{k_1}, \varepsilon_{k_2} \in \bar{\mathbf{p}}$ (wlog $k_1 < k_2$) we have: $\varepsilon_{k_1} - \varepsilon_{k_2} = \sum_{r=k_1}^{k_2-1} \alpha_r$. So with Remark 1.1.8 we know that there is a Dyck path $\mathbf{p} \in D_{\omega_n}$ with $\varepsilon_{k_1}, \varepsilon_{k_2} \in \mathbf{p}$. This observation implies that the elements $\bar{\mathbf{p}} \in \overline{D}_{\omega_n}^{\mathbf{B}_n}$ have two possible forms:

$$(4.8) \quad (B_1) \bar{\mathbf{p}} = \{\varepsilon_k, \varepsilon_{i_2, j_2}, \dots, \varepsilon_{i_r, j_r}\} \quad \text{or} \quad (B_2) \bar{\mathbf{p}} = \{\varepsilon_{i_1, j_1}, \dots, \varepsilon_{i_t, j_t}\}.$$

So we can characterize the elements $\bar{\mathbf{p}} \in \overline{D}_{\omega_n}^{\mathbf{B}_n}$ as follows.

Proposition 4.2.3. For $\bar{\mathbf{p}} \in \mathcal{P}(\Delta_+^{\omega_n})$ arbitrary we have:

$$(4.9) \quad \bar{\mathbf{p}} \in \overline{D}_{\omega_n}^{\mathbf{B}_n} \Leftrightarrow \begin{cases} \bar{\mathbf{p}} \text{ is of the form } (B_1), \text{ with (a) and (b),} \\ \bar{\mathbf{p}} \text{ is of the form } (B_2), \text{ with (b).} \end{cases}$$

In addition: $\bar{\mathbf{p}} \in \overline{D}_{\omega_n}^{\mathbf{B}_n} \Rightarrow \begin{cases} s \leq \lceil \frac{n}{2} \rceil, \bar{\mathbf{p}} \text{ is of the form } (B_1), \\ s \leq \lfloor \frac{n}{2} \rfloor, \bar{\mathbf{p}} \text{ is of the form } (B_2), \end{cases}$

with $s = |\bar{\mathbf{p}}|$. The properties (a) and (b) are defined by

- (a) $\forall 1 \leq l \leq s : k < i_l < j_l$,
- (b) $\forall \alpha_{i_l, j_l}, \alpha_{i_m, j_m} \in \bar{\mathbf{p}}, i_l \leq i_m : i_l < i_m < j_m < j_l$.

Proof. First we prove (4.9): “ \Leftarrow ”: Let $\mathbf{p} = \{\varepsilon_k, \varepsilon_{i_2, j_2}, \dots, \varepsilon_{i_s, j_s}\}$ be an element of form (B_1) with the properties (a) and (b). Assume there are two roots $x, y \in \mathbf{p}$ such that there exists a Dyck path $\mathbf{q} \in D_{\omega_n}$ containing them.

1. Case: $x = \varepsilon_k$ and $y = \varepsilon_{i_m, j_m}$, for $1 \leq m \leq s$. Then we have

$$\varepsilon_{i_m, j_m} - \varepsilon_k = \sum_{r=i_m}^{j_m-1} \alpha_r + 2 \sum_{r=j_m}^n \alpha_r - \sum_{r=k}^n \alpha_r = - \sum_{r=k}^{i_m-1} \alpha_r + \sum_{r=j_m}^n \alpha_r.$$

Hence there is no Dyck path $\mathbf{q} \in D_{\omega_n}$ such that x and y are contained in \mathbf{q} . This is a contradiction to the assumption.

2. Case: $x = \varepsilon_{i_m, j_m}$ and $y = \varepsilon_{i_l, j_l}$, wlog $i_l < i_m$. Then we have

$$\varepsilon_{i_l, j_l} - \varepsilon_{i_m, j_m} = \sum_{r=i_l}^{j_l-1} \alpha_r + 2 \sum_{r=j_l}^n \alpha_r - \sum_{r=i_m}^{j_m-1} \alpha_r - 2 \sum_{r=j_m}^n \alpha_r = \sum_{r=i_l}^{i_m-1} \alpha_r - \sum_{r=j_m}^{j_l-1} \alpha_r.$$

This is a contradiction to our assumption and hence: $\mathbf{p} \in \overline{D}_{\omega_n}^{\mathbf{B}_n}$.

Let \mathbf{p} be of form (B_2) with property (b), and assume there are two roots $x, y \in \mathbf{p}$ such that there exists a Dyck path $\mathbf{q} \in D_{\omega_n}$ containing them. Like in the second case of our previous consideration the assumption is false and therefore: $\mathbf{p} \in \overline{D}_{\omega_n}^{\mathbf{B}_n}$.

“ \Rightarrow ”: Let $\mathbf{p} \in \overline{D}_{\omega_n}^{\text{Bn}}$. Then we know from Remark 4.2.2 that \mathbf{p} is of the form (B_1) or (B_2) . Let $\mathbf{p} = \{\varepsilon_k, \varepsilon_{i_1, j_1}, \dots, \varepsilon_{i_s, j_s}\}$ be of form (B_1) , with $i_l < j_l$ for all $1 \leq l \leq s$.

1. Step: Assume $\exists 1 \leq m \leq s : k > i_m$. Then we have:

$$\varepsilon_{i_m, j_m} - \varepsilon_k = \sum_{r=i_m}^{j_m-1} \alpha_r + 2 \sum_{r=j_m}^n \alpha_r - \sum_{r=k}^n \alpha_r = \sum_{r=i_m}^{k-1} \alpha_r + \sum_{r=j_m}^n \alpha_r.$$

So by Remark 1.1.8 this contradicts $\mathbf{p} \in \overline{D}_{\omega_n}^{\text{Bn}}$. Hence: $k < i_m$ for all $1 \leq m \leq s$.

Let $\varepsilon_{i_l, j_l}, \varepsilon_{i_m, j_m} \in \mathbf{p}$ be two roots with $\varepsilon_{i_l, j_l} \neq \varepsilon_{i_m, j_m}$. We assume wlog $i_l \leq i_m$.

2. Step: Assume $i_l = i_m =: y$. Set $x = \min\{j_l, j_m\}$ and $\bar{x} = \max\{j_l, j_m\}$:

$$\varepsilon_{y, x} - \varepsilon_{y, \bar{x}} = \sum_{r=y}^{x-1} \alpha_r + 2 \sum_{r=x}^n \alpha_r - \sum_{r=y}^{\bar{x}-1} \alpha_r - 2 \sum_{r=\bar{x}}^n \alpha_r = \sum_{r=x}^{\bar{x}} \alpha_r.$$

Again by Remark 1.1.8 this contradicts $\mathbf{p} \in \overline{D}_{\omega_n}^{\text{Bn}}$ and we have: $i_l < i_m$.

3. Step: Let $i_l < i_m$ and assume $j_l = j_m =: x$, we consider:

$$\varepsilon_{i_l, x} - \varepsilon_{i_m, x} = \sum_{r=i_l}^x \alpha_r + 2 \sum_{r=x}^n \alpha_r - \sum_{r=i_m}^x \alpha_r - 2 \sum_{r=x}^n \alpha_r = \sum_{r=i_l}^{i_m-1} \alpha_r.$$

This contradicts $\mathbf{p} \in \overline{D}_{\omega_n}^{\text{Bn}}$ by Remark 1.1.8, so: $j_l \neq j_m$.

4. Step: $(i_l < i_m < j_m) \wedge (i_l < j_l)$. So there are three possible cases:

(a) $i_l < j_l < i_m < j_m$, (b) $i_l < i_m < j_l < j_m$ and (c) $i_l < i_m < j_m < j_l$.

Let us assume ε_{i_l, j_l} and ε_{i_m, j_m} have the property of case (a):

$$\varepsilon_{i_l, j_l} - \varepsilon_{i_m, j_m} = \sum_{r=i_l}^{j_l-1} \alpha_r + 2 \sum_{r=j_l}^n \alpha_r - \sum_{r=i_m}^{j_m-1} \alpha_r - 2 \sum_{r=j_m}^n \alpha_r = \sum_{r=i_l}^{j_m-1} \alpha_r + 2 \sum_{r=j_l}^{i_m-1} \alpha_r + \sum_{r=i_m}^{j_m-1} \alpha_r.$$

This contradicts $\mathbf{p} \in \overline{D}_{\omega_n}^{\text{Bn}}$ by Remark 1.1.8. We assume now that ε_{i_l, j_l} and ε_{i_m, j_m} have the property of case (b):

$$\varepsilon_{i_l, j_l} - \varepsilon_{i_m, j_m} = \sum_{r=i_l}^{j_l-1} \alpha_r + 2 \sum_{r=j_l}^n \alpha_r - \sum_{r=i_m}^{j_m-1} \alpha_r - 2 \sum_{r=j_m}^n \alpha_r = \sum_{r=i_l}^{i_m-1} \alpha_r + \sum_{r=j_l}^{j_m-1} \alpha_r.$$

Again by Remark 1.1.8 this contradicts $\mathbf{p} \in \overline{D}_{\omega_n}^{\text{Bn}}$. Finally we conclude that two roots $\varepsilon_{i_l, j_l}, \varepsilon_{i_m, j_m} \in \mathbf{p}$, with $i_l \leq i_m$, satisfy (c): $i_l < i_m < j_m < j_l$. To prove this statement for a $\mathbf{p} \in \overline{D}_{\omega_n}^{\text{Bn}}$ of form (B_2) we only have to restrict our consideration to the second, third and fourth step.

It remains to show that the cardinality s of \mathbf{p} is bounded by $\lceil \frac{n}{2} \rceil$ respectively $\lfloor \frac{n}{2} \rfloor$. Again we consider the two possible cases:

1. Case: $\mathbf{p} = \{\varepsilon_k, \varepsilon_{i_2, j_2}, \dots, \varepsilon_{i_s, j_s}\}$ is of the form (B_1) and we assume $|\mathbf{p}| = s > \lfloor \frac{n}{2} \rfloor$. Then we know from our previous consideration that after reordering the roots in \mathbf{p} we have a strictly increasing chain of integers:

$$(4.10) \quad C_{\mathbf{p}} : k < i_2 < i_3 \cdots < i_s < j_s < j_{s-1} < \cdots < j_3 < j_2.$$

So there are $2s - 1$ different integers, where each of these correspond to a ε_i for $1 \leq i \leq n$. By assumption we know $2s - 1 \geq 2(\lceil \frac{n}{2} \rceil + 1) - 1 \geq n + 1$, but there are only n different elements in $\{\varepsilon_r \mid 1 \leq r \leq n\}$. So this is a contradiction and hence: $|\mathbf{p}| = s \leq \lceil \frac{n}{2} \rceil$.

2. Case: $\mathbf{p} = \{\varepsilon_{i_1, j_1}, \dots, \varepsilon_{i_s, j_s}\}$ is of the form (B_2) and we assume $|\mathbf{p}| = s > \lfloor \frac{n}{2} \rfloor$. As in the first case we have a strictly increasing chain of integers:

$$(4.11) \quad C_{\mathbf{p}} : i_1 < i_2 < \dots < i_s < j_s < j_{s-1} < \dots < j_2 < j_1.$$

So we have $2s$ different integers corresponding to at most n different elements in $\{\varepsilon_r \mid 1 \leq r \leq n\}$, but by assumption we have $2s \geq 2(\lfloor \frac{n}{2} \rfloor + 1) \geq n + 1$. Again we have a contradiction and therefore: $|\mathbf{p}| = s \leq \lfloor \frac{n}{2} \rfloor$. \square

Because of Corollary 3.1.5 we know that the elements $\{f^{\mathbf{s}}v_{\omega_n} \mid \mathbf{s} \in S(\omega_n)\}$ span $V(\omega_n)$ and by Proposition 1.1.10 there is a bijection between $S(\omega_n)$ and $\overline{D}_{\omega_n}^{\text{Bn}}$. We want to show that these elements are linear independent. To achieve that we will show that $|\overline{D}_{\omega_n}^{\text{Bn}}| = \dim V(\omega_n)$. To be more explicit:

Proposition 4.2.4. $|\overline{D}_{\omega_n}^{\text{Bn}}| = \dim V(\omega_n) = 2^n$.

Proof. We know from (4.9) that for an arbitrary element $\overline{\mathbf{p}} \in \overline{D}_{\omega_n}^{\text{Bn}}$ the number of roots s in $\overline{\mathbf{p}}$ is bounded by $\lceil \frac{n}{2} \rceil$ respective by $\lfloor \frac{n}{2} \rfloor$. So the number of integers occurring in $C_{\overline{\mathbf{p}}}$ (see (4.10) and (4.11)) is also bounded:

$$(4.12) \quad |C_{\overline{\mathbf{p}}}| = \begin{cases} 2s - 1 \leq 2\lceil \frac{n}{2} \rceil - 1 \leq n, & \overline{\mathbf{p}} \text{ is of the form } (B_1), \\ 2s \leq 2\lfloor \frac{n}{2} \rfloor \leq n, & \overline{\mathbf{p}} \text{ is of the form } (B_2). \end{cases}$$

In order to simplify our notation, we define $l := |C_{\overline{\mathbf{p}}}|$, so we have for an arbitrary $\overline{\mathbf{p}} \in \overline{D}_{\omega_n}^{\text{Bn}} : 0 \leq l \leq n$. Further we define the subsets $\overline{D}_{\omega_n}^{\text{Bn}}(l) \subset \overline{D}_{\omega_n}^{\text{Bn}}$:

$$(4.13) \quad \overline{D}_{\omega_n}^{\text{Bn}}(l) := \{\overline{\mathbf{p}} \in \overline{D}_{\omega_n}^{\text{Bn}} \mid |C_{\overline{\mathbf{p}}}| = l\}, \quad \forall 0 \leq l \leq n.$$

So the elements in $\overline{D}_{\omega_n}^{\text{Bn}}(l)$ are parametrized by l totally ordered integers u_i in $\{r \mid 1 \leq r \leq n\}$, $\forall 1 \leq i \leq l$. Hence we conclude: $|\overline{D}_{\omega_n}^{\text{Bn}}(l)| \leq \binom{n}{l}$, $\forall 1 \leq l \leq n$ and so

$$(4.14) \quad |\overline{D}_{\omega_n}^{\text{Bn}}| = \left| \bigcup_{l=1}^n \overline{D}_{\omega_n}^{\text{Bn}}(l) \right| = \sum_{l=0}^n |\overline{D}_{\omega_n}^{\text{Bn}}(l)| \leq \sum_{l=0}^n \binom{n}{l} = 2^n.$$

We also know from Corollary 3.1.5 that we have $|\overline{D}_{\omega_n}^{\text{Bn}}| \geq \dim V(\omega_n) = \binom{n}{1} = 2^n$. Finally we conclude: $|\overline{D}_{\omega_n}^{\text{Bn}}| = 2^n$. \square

Example 4.2.5. The polytope $P(m\omega_3)$ in the case $\mathfrak{g} = \mathfrak{so}_7$ has the following shape.

$$P(m\omega_3) = \left\{ \mathbf{x} \in \mathbb{R}_{\geq 0}^6 \mid \begin{array}{l} x_1 + x_2 + x_3 + x_5 + x_6 \leq m \\ x_1 + x_2 + x_4 + x_5 + x_6 \leq m \end{array} \right\}.$$

Proposition 4.2.4 implies immediately:

Proposition 4.2.6. The vectors $f^{\mathbf{s}}v_{\omega_n}$, $\mathbf{s} \in S(\omega_n)$ are a FFL basis of $V(\omega_n)$. \square

4.3. **Type C_n .** Let \mathfrak{g} be a simple Lie algebra of type C_n for $n \geq 3$ with the associated Dynkin diagram

$$C_n \quad \circ_1 \text{---} \circ_2 \text{---} \cdots \text{---} \circ_{n-2} \text{---} \circ_{n-1} \text{---} \circ_n \leftarrow \circ_n$$

For all fundamental weights ω_k we have $\langle \omega_k, \theta^\vee \rangle = 1$, where $\theta = (2, 2, \dots, 2, 1)$ is the highest root and $\theta^\vee = (1, 1, \dots, 1)$ the corresponding coroot. But only for ω_1 the associated Hasse diagram $H(\mathfrak{n}_{\omega_1}^-)_{\mathfrak{g}}$ has no i -chains. In fact for $1 \leq k \leq n$, $H(\mathfrak{n}_{\omega_k}^-)_{\mathfrak{g}}$ has $k - 1$ different i -chains, with $1 \leq i \leq k - 1$. The following example explains, why we are not able to rewrite the diagram in these cases, with our approach.

For all ω_k with $k \neq 1$ we have the following 1-chain.

$$\beta_1 \xrightarrow{1} \beta_2 \xrightarrow{1} \beta_3.$$

Here $\beta_1 = 2\alpha_1 + \dots + 2\alpha_{n-1} + \alpha_n$ is the highest root, $\beta_2 = \alpha_1 + 2\alpha_2 + \dots + 2\alpha_{n-1} + \alpha_n$ and $\beta_3 = 2\alpha_2 + \dots + 2\alpha_{n-1} + \alpha_n$. Note that $\beta_1 - \beta_3 = 2\alpha_1$, which is not a root. Further, because β_1 is the highest root, there are no roots $\gamma \in \Delta_+$, $\nu \in \Delta_+^{\omega_k}$ with $\partial_\gamma f_\nu = f_3$, except for $\nu = \beta_2$. Hence it is more involved to rewrite the diagram into a diagram without k -chains such that there is a path connecting β_1 and β_3 . Nevertheless, in [FFoL11b] similar statements to Theorem A and Theorem B were proven for arbitrary dominant integral weights.

Now we consider $\omega = \omega_1$. Then we have $2n - 1 = N$ and Δ_+^ω is given by

| | | | |
|-------------------------------------|-------------------------------------|-----|---------------------------------|
| $\beta_1 = (2, 2, \dots, 2, 1)$ | $\beta_2 = (1, 2, \dots, 2, 1)$ | ... | $\beta_n = (1, 1, \dots, 1, 1)$ |
| $\beta_{n+1} = (1, 1, \dots, 1, 0)$ | $\beta_{n+2} = (1, \dots, 1, 0, 0)$ | ... | $\beta_N = (1, 0, \dots, 0, 0)$ |

The diagram $H(\mathfrak{n}_{\omega_1}^-)_{\mathfrak{g}}$ has the following form.

$$\beta_1 \xrightarrow{1} \beta_2 \xrightarrow{2} \beta_3 \xrightarrow{3} \cdots \xrightarrow{n-2} \beta_{n-1} \xrightarrow{n-1} \beta_n \xrightarrow{n} \beta_{n+1} \xrightarrow{n-1} \cdots \xrightarrow{2} \beta_N.$$

There are no k -chains and the associated polytope is given by

$$P(m\omega) = \{\mathbf{x} \in \mathbb{R}_{\geq 0}^N \mid x_1 + x_2 + \cdots + x_N \leq m\}.$$

By Corollary 3.1.5 the elements $v_\omega, f_1 v_\omega, f_2 v_\omega, \dots, f_N v_\omega$ span $V(\omega)$ and with [Car05, p295] we know $\dim V(\omega) = 2n$. From these observations we get immediately:

Proposition 4.3.1. *The set $\mathbb{B}_\omega = \{f^{\mathbf{s}} v_\omega \mid \mathbf{s} \in S(\omega)\}$ is a FFL basis of $V(\omega)$. \square*

4.4. **Type D_n .** Let \mathfrak{g} be a simple Lie algebra of type D_n with associated Dynkin diagram

$$D_n \quad \circ_1 \text{---} \circ_2 \text{---} \cdots \text{---} \circ_{n-3} \text{---} \circ_{n-2} \begin{matrix} \swarrow \circ_{n-1} \\ \searrow \circ_n \end{matrix}$$

The highest root in type D_n is of the form $\theta = \alpha_1 + 2 \sum_{i=2}^{n-2} \alpha_i + \alpha_{n-1} + \alpha_n$. Since \mathfrak{g} is simply-laced we have $\theta^\vee = \alpha_1^\vee + 2 \sum_{i=2}^{n-2} \alpha_i^\vee + \alpha_{n-1}^\vee + \alpha_n^\vee$. Hence $\langle \omega, \theta^\vee \rangle = 1 \Leftrightarrow \omega \in \{\omega_1, \omega_{n-1}, \omega_n\}$.

First we consider the case $\omega = \omega_1$. Then we have $2n - 2 = N$ and $\Delta_+^{\omega_1}$ has the following form:

| | | | |
|---|---------------------------------------|-----|---|
| $\beta_1 = (1, 2, 2, \dots, 2, 1, 1)$ | $\beta_2 = (1, 1, 2, \dots, 2, 1, 1)$ | ... | $\beta_{n-2} = (1, 1, 1, \dots, 1, 1, 1)$ |
| $\beta_{n-1} = (1, 1, 1, \dots, 1, 0, 1)$ | $\beta_n = (1, 1, 1, \dots, 1, 1, 0)$ | ... | $\beta_N = (1, 0, 0, \dots, 0, 0, 0)$ |

The Hasse diagram has no k -chain. In addition in \overline{D}_{ω_1} there are only co-chains of cardinality at most 1, except for one with cardinality 2.

$$\begin{array}{ccccccc}
 & & & & \beta_{n-1} & & \\
 & & & & \nearrow^{n-1} & \searrow^n & \\
 \beta_1 & \xrightarrow{2} & \beta_2 & \xrightarrow{3} & \beta_3 & \xrightarrow{4} & \dots & \xrightarrow{n-2} & \beta_{n-2} & & \beta_{n+1} & \xrightarrow{n-2} & \beta_{n+2} & \xrightarrow{n-3} & \dots & \xrightarrow{2} & \beta_N. \\
 & & & & \searrow^n & \nearrow^{n-1} & \\
 & & & & \beta_n & &
 \end{array}$$

Associated to this diagram we get the following polytope for $m \in \mathbb{Z}_{\geq 0}$:

$$P(m\omega) = \left\{ \mathbf{x} \in \mathbb{R}_{\geq 0}^N \mid \begin{array}{l} x_1 + \dots + x_{n-2} + x_{n-1} + x_{n+1} + \dots + x_N \leq m \\ x_1 + \dots + x_{n-2} + x_n + x_{n+1} + \dots + x_N \leq m \end{array} \right\}.$$

By Corollary 3.1.5 the elements $\mathbb{B}_{\omega_1} = \{v_{\omega_1}, f_1 v_{\omega_1}, f_2 v_{\omega_1}, \dots, f_N v_{\omega_1}, f_{n-1} f_n v_{\omega_1}\}$ span $V(\omega_1)$ and with [Car05, p. 280] we have $\dim V(\omega_1) = 2n$. From these observations we get immediately.

Proposition 4.4.1. *The vectors $f^s v_{\omega_1}, \mathbf{s} \in S(\omega_1)$ are a FFL basis of $V(\omega_1)$. \square*

For most of the proofs of the statements in the case $\omega = \omega_{n-1}, \omega_n$ we will refer to the proofs of the corresponding statements for type B_n .

Now we consider the case $\omega = \omega_{n-1}$. For further considerations it will be convenient to describe the roots and fundamental weights of \mathfrak{g} in terms of an orthogonal basis $\{\varepsilon_i \mid 1 \leq i \leq n\}$. Then $\Delta_+^{\omega_{n-1}}$ is given by

$$(4.15) \quad \{\varepsilon_{i,j} = \varepsilon_i + \varepsilon_j \mid 1 \leq i < j \leq n-1\} \cup \{\varepsilon_{k,\bar{n}} = \varepsilon_k - \varepsilon_n \mid 1 \leq k \leq n-1\}.$$

The total order on $\Delta_+^{\omega_{n-1}}$ is defined like in the B_n, ω_n -case (see Figure 3). The elements of $\Delta_+^{\omega_{n-1}}$ correspond to $\varepsilon_{i,j} = \sum_{r=i}^{j-1} \alpha_r + 2 \sum_{r=j}^{n-2} \alpha_r + \alpha_{n-1} + \alpha_n$ and $\varepsilon_{k,\bar{n}} = \sum_{r=k}^{n-1} \alpha_r$. The highest weight of $V(\omega_{n-1})$ has the description $\omega_{n-1} = \frac{1}{2} \left(\sum_{r=1}^{n-1} \varepsilon_r - \varepsilon_n \right)$. Further the lowest weight is $-\omega_{n-1} = -\frac{1}{2} \left(\sum_{r=1}^{n-1} \varepsilon_r - \varepsilon_n \right)$. With this observation, the fact that ω_{n-1} is minuscule and (4.15) we see that

$$\mathbb{B}_{V(\omega_{n-1})} = \left\{ f_\alpha v_{\omega_{n-1}} \mid \alpha = \frac{1}{2} \sum_{r=1}^n l_r \varepsilon_r, l_r = \pm 1, \forall 1 \leq r \leq n, 2 \nmid \#\{l_r \mid l_r = -1\} \right\}$$

is a basis of $V(\omega_{n-1})$. We note that $|\mathbb{B}_{V(\omega_{n-1})}| = 2^{n-1} = \dim V(\omega_{n-1})$.

Remark 4.4.2. *Similar arguments as in Remark 4.2.2 show that the elements $\bar{\mathbf{p}} \in \overline{D}_{\omega_{n-1}}^{\mathbb{D}_n}$ have two possible forms:*

$$(4.16) \quad (D_1) \bar{\mathbf{p}} = \{\varepsilon_{k,\bar{n}}, \varepsilon_{i_2, j_2}, \dots, \varepsilon_{i_r, j_r}\} \text{ or } (D_2) \bar{\mathbf{p}} = \{\varepsilon_{i_1, j_1}, \dots, \varepsilon_{i_t, j_t}\}.$$

We denote with $\mathbf{1}_{2|n} : \mathbb{Z}_{\geq 0} \rightarrow \{0, 1\}$ (respective $\mathbf{1}_{2 \nmid n}$) the Indicator function for the odd (respective even) integers, which is defined by $\mathbf{1}_{2|n}(n) = 1$ if $2 \nmid n$ (respective $\mathbf{1}_{2 \nmid n}(n) = 1$ if $2 \mid n$) and 0 otherwise. So we can characterize the elements $\bar{\mathbf{p}} \in \overline{D}_{\omega_{n-1}}^{\mathbb{D}_n}$ as follows

Proposition 4.4.3. *For $\bar{\mathbf{p}} \in \mathcal{P}(\Delta_+^{\omega_{n-1}})$ arbitrary we have:*

$$(4.17) \quad \bar{\mathbf{p}} \in \overline{D}_{\omega_{n-1}}^{\mathbb{D}_n} \Leftrightarrow \begin{cases} \bar{\mathbf{p}} \text{ is of the form } (D_1), \text{ with (a) and (b),} \\ \bar{\mathbf{p}} \text{ is of the form } (D_2), \text{ with (b).} \end{cases}$$

In addition: $\bar{\mathbf{p}} \in \overline{D}_{\omega_{n-1}}^{\mathbf{D}_n} \Rightarrow \begin{cases} s \leq \lfloor \frac{n}{2} \rfloor - \mathbf{1}_{2|n}(n), & \bar{\mathbf{p}} \text{ is of the form } (D_1), \\ s \leq \lfloor \frac{n}{2} \rfloor - \mathbf{1}_{2 \nmid n}(n), & \bar{\mathbf{p}} \text{ is of the form } (D_2), \end{cases}$
with $s = |\bar{\mathbf{p}}|$. The properties (a) and (b) are defined by

- (a) $\forall 1 \leq l \leq s : k < i_l < j_l$,
(b) $\forall \alpha_{i_l, j_l}, \alpha_{i_m, j_m} \in \bar{\mathbf{p}}, i_l \leq i_m : i_l < i_m < j_m < j_l$.

Proof. To prove this statement we adapt the idea of Proposition 4.2.3. We use exactly the same approach but we consider $\Delta_+^{\omega_{n-1}}$ of type \mathbf{D}_n .

To check that the cardinality s of an arbitrary element $\bar{\mathbf{p}} \in \overline{D}_{\omega_{n-1}}^{\mathbf{D}_n}$ is bounded, like we claim on the rhs of (4.17), we use only fundamental combinatorics, again analogue to the idea of the proof of Proposition 4.2.3. \square

Because of Corollary 3.1.5 we know that the elements $\{f^{\mathbf{s}}v_{\omega_{n-1}} \mid \mathbf{s} \in S(\omega_{n-1})\}$ span $V(\omega_{n-1})$ and by Proposition 1.1.10 there is a bijection between $S(\omega_{n-1})$ and $\overline{D}_{\omega_{n-1}}^{\mathbf{D}_n}$. We want to show that these elements are linear independent. To achieve that we will show that $|\overline{D}_{\omega_{n-1}}^{\mathbf{D}_n}| = \dim V(\omega_{n-1})$. To be more explicit:

Proposition 4.4.4. $|\overline{D}_{\omega_{n-1}}^{\mathbf{D}_n}| = \dim V(\omega_{n-1}) = 2^{n-1}$.

Proof. This is a direct consequence of Lemma 4.4.10 and Proposition 4.2.4. \square

Proposition 4.4.4 implies immediately

Proposition 4.4.5. $\mathbb{B}_{\omega_{n-1}} = \{f^{\mathbf{s}}v_{\omega_{n-1}} \mid \mathbf{s} \in S(\omega_{n-1})\}$ is a basis for $V(\omega_{n-1})$. \square

Finally we consider the case $\omega = \omega_n$. For the proofs of the statements in this case we refer to the proofs of the analogous statements in the previous case $\omega = \omega_{n-1}$ and the \mathbf{B}_n, ω_n -case.

The set of roots $\Delta_+^{\omega_n}$, where $\alpha_n = \varepsilon_{n-1} + \varepsilon_n$ is a summand, is given by:

$$(4.18) \quad \{\varepsilon_{i,j} = \varepsilon_i + \varepsilon_j \mid 1 \leq i < j \leq n-1\} \cup \{\varepsilon_{k,n} = \varepsilon_k + \varepsilon_n \mid 1 \leq k \leq n-1\}.$$

Again the total order on $\Delta_+^{\omega_n}$ is defined like in the \mathbf{B}_n, ω_n -case (see Figure 3), where the elements of $\Delta_+^{\omega_n}$ correspond to $\varepsilon_{i,j} = \sum_{r=i}^{j-1} \alpha_r + 2 \sum_{r=j}^{n-2} \alpha_r + \alpha_{n-1} + \alpha_n$ and $\varepsilon_{k,n} = \sum_{r=k}^n \alpha_r, r \neq n-1$. The highest weight of $V(\omega_n)$ has the description $\omega_n = \frac{1}{2} (\sum_{r=1}^n \varepsilon_r)$. Further the lowest weight is $-\omega_n = -\frac{1}{2} (\sum_{r=1}^n \varepsilon_r)$. As before we see that

$$(4.19) \quad \mathbb{B}_{V(\omega_n)} = \left\{ f_{\alpha} v_{\omega_n} \mid \alpha = \frac{1}{2} \sum_{r=1}^n l_r \varepsilon_r, l_r \in \{-1, 1\}, \forall 1 \leq r \leq n, 2 \mid \#\{l_r \mid l_r = -1\} \right\}$$

is a basis of $V(\omega_n)$. We note that $|\mathbb{B}_{\omega_n}| = 2^{n-1} = \dim V(\omega_n)$.

Remark 4.4.6. Similar arguments as in Remark 4.2.2 show that the elements $\bar{\mathbf{p}} \in \overline{D}_{\omega_n}^{\mathbf{D}_n}$ have two possible forms:

$$(4.20) \quad (D_1^*) \bar{\mathbf{p}} = \{\varepsilon_{k,n}, \varepsilon_{i_2, j_2}, \dots, \varepsilon_{i_s, j_s}\} \quad \text{and} \quad (D_2^*) \bar{\mathbf{p}} = \{\varepsilon_{i_1, j_1}, \dots, \varepsilon_{i_s, j_s}\}.$$

So we can characterize the elements $\bar{\mathbf{p}} \in \overline{D}_{\omega_n}^{\mathbf{D}_n}$ as follows:

Proposition 4.4.7. For $\bar{\mathbf{p}} \in \mathcal{P}(\Delta_+^{\omega_n})$ arbitrary we have:

$$(4.21) \quad \bar{\mathbf{p}} \in \bar{D}_{\omega_n}^{\mathbf{D}_n} \Leftrightarrow \begin{cases} \bar{\mathbf{p}} \text{ is of the form } (D_1^*), \text{ with (a) and (b),} \\ \bar{\mathbf{p}} \text{ is of the form } (D_2^*), \text{ with (b).} \end{cases}$$

In addition: $\bar{\mathbf{p}} \in \bar{D}_{\omega_n}^{\mathbf{D}_n} \Rightarrow \begin{cases} s \leq \lceil \frac{n}{2} \rceil - \mathbf{1}_{2 \mid n}(n), \bar{\mathbf{p}} \text{ is of the form } (D_1^*), \\ s \leq \lfloor \frac{n}{2} \rfloor - \mathbf{1}_{2 \nmid n}(n), \bar{\mathbf{p}} \text{ is of the form } (D_2^*), \end{cases}$

with $s = |\bar{\mathbf{p}}|$. The properties (a) and (b) are defined by

- (a) $\forall 1 \leq l \leq s : k < i_l < j_l$,
- (b) $\forall \alpha_{i_l, j_l}, \alpha_{i_m, j_m} \in \bar{\mathbf{p}}, i_l \leq i_m : i_l < i_m < j_m < j_l$.

Proof. To prove this statement we refer to the proof of Proposition 4.4.3. \square

Because of Corollary 3.1.5 we know that the elements of $\bar{D}_{\omega_n}^{\mathbf{D}_n}$ span the highest weight module $V(\omega_n)$. But we still have to show that these elements are linear independent. To achieve that we will show:

Proposition 4.4.8. $|\bar{D}_{\omega_n}^{\mathbf{D}_n}| = \dim V(\omega_n) = 2^{n-1}$.

Proof. This is a direct consequence of Lemma 4.4.10 and Proposition 4.2.4. \square

Proposition 4.4.8 implies immediately

Proposition 4.4.9. The set $\mathbb{B}_{\omega_n} = \{f^{\mathbf{s}}v_{\omega_n} \mid \mathbf{s} \in S(\omega_n)\}$ is a basis for $V(\omega_n)$. \square

The following Lemma gives us a very useful connection between the co-chains of \mathfrak{g} of type \mathbf{B}_{n-1} and \mathbf{D}_n :

Lemma 4.4.10. We have: $|\bar{D}_{\omega_{n-1}}^{\mathbf{D}_n}| = |\bar{D}_{\omega_{n-1}}^{\mathbf{B}_{n-1}}|$ and $|\bar{D}_{\omega_n}^{\mathbf{D}_n}| = |\bar{D}_{\omega_{n-1}}^{\mathbf{B}_{n-1}}|$.

Proof. We only use basic combinatorics to prove this statement. \square

4.5. **Type \mathbf{E}_6 .** Let \mathfrak{g} be a simple Lie algebra of type \mathbf{E}_6 with associated Dynkin diagram

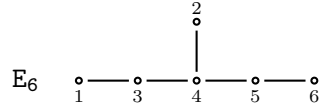

We have $\langle \omega, \theta^\vee \rangle = 1 \Leftrightarrow \omega = \omega_1, \omega_6$ and first we fix ω to be ω_6 . The set is $\Delta_+^{\omega_6}$ given as follows:

| | |
|--------------------------------|-----------------------------------|
| $\beta_1 = (1, 2, 2, 3, 2, 1)$ | $\beta_9 = (1, 1, 1, 1, 1, 1)$ |
| $\beta_2 = (1, 1, 2, 3, 2, 1)$ | $\beta_{10} = (0, 1, 1, 1, 1, 1)$ |
| $\beta_3 = (1, 1, 2, 2, 2, 1)$ | $\beta_{11} = (1, 0, 1, 1, 1, 1)$ |
| $\beta_4 = (1, 1, 1, 2, 2, 1)$ | $\beta_{12} = (0, 0, 1, 1, 1, 1)$ |
| $\beta_5 = (1, 1, 2, 2, 1, 1)$ | $\beta_{13} = (0, 1, 0, 1, 1, 1)$ |
| $\beta_6 = (0, 1, 1, 2, 2, 1)$ | $\beta_{14} = (0, 0, 0, 1, 1, 1)$ |
| $\beta_7 = (1, 1, 1, 2, 1, 1)$ | $\beta_{15} = (0, 0, 0, 0, 1, 1)$ |
| $\beta_8 = (0, 1, 1, 2, 1, 1)$ | $\beta_{16} = (0, 0, 0, 0, 0, 1)$ |

The Hasse diagram $H(\mathfrak{n}_{\omega_6}^-)_{\mathbf{E}_6}$ has no k -chains and the maximal cardinality of a co-chain of $H(\mathfrak{n}_{\omega_6}^-)_{\mathbf{E}_6}$ is two (see Appendix, Figure 4). The associated polytope is given for $m \in \mathbb{Z}_{\geq 0}$ by:

$$P(m\omega_6) = \{\mathbf{x} \in \mathbb{R}_{\geq 0}^{16} \mid \sum_{\beta_j \in \mathbf{p}} x_j \leq m, \forall \mathbf{p} \in D_{\omega_6}\},$$

in particular see Appendix, Table 4 for the non-redundant inequalities.

Proposition 4.5.1. *The set $\mathbb{B}_{\omega_6} = \{f^{\mathbf{s}}v_{\omega_6} \mid \mathbf{s} \in S(\omega_6)\}$ is a FLL basis of $V(\omega_6)$.*

Proof. The co-chains of the Hasse diagram give us immediately:

$$\mathbb{B}_{\omega_6} = \{v_{\omega_6}, f_1v_{\omega_6}, f_2v_{\omega_6}, \dots, f_{16}v_{\omega_6}, f_4f_5v_{\omega_6}, f_5f_6v_{\omega_6}, f_6f_7v_{\omega_6}, f_6f_9v_{\omega_6}, \\ f_8f_9v_{\omega_6}, f_8f_{10}v_{\omega_6}, f_8f_{11}v_{\omega_6}, f_{10}f_{11}v_{\omega_6}, f_{11}f_{13}v_{\omega_6}, f_{12}f_{13}v_{\omega_6}\}.$$

Note that there are 27 elements in \mathbb{B}_{ω_6} . By Corollary 3.1.5, we get that \mathbb{B}_{ω_6} is a spanning set of $V(\omega_6)$. By [Car05, p. 303] we have $\dim V(\omega_6) = 27$ and therefore the claim holds. \square

It is shown in Figure 4 that the Hasse diagrams $H(\mathfrak{n}_{\omega_1}^-)_{E_6}$ and $H(\mathfrak{n}_{\omega_6}^-)_{E_6}$ have a very similar shape. So with same arguments as above we conclude:

Proposition 4.5.2. *The vectors $f^{\mathbf{s}}v_{\omega_1}$, $\mathbf{s} \in S(\omega_1)$ are a FLL basis of $V(\omega_1)$. \square*

4.6. **Type E_7 .** Let \mathfrak{g} be the simple Lie algebra of type E_7 with associated Dynkin diagram

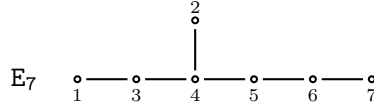

In this case $\omega = \omega_7$ is the only fundamental weight satisfying $\langle \omega, \theta^\vee \rangle = 1$.

| | | |
|-----------------------------------|--------------------------------------|--------------------------------------|
| $\beta_1 = (2, 2, 3, 4, 3, 2, 1)$ | $\beta_{10} = (1, 1, 2, 3, 2, 1, 1)$ | $\beta_{19} = (1, 1, 1, 1, 1, 1, 1)$ |
| $\beta_2 = (1, 2, 3, 4, 3, 2, 1)$ | $\beta_{11} = (1, 1, 1, 2, 2, 2, 1)$ | $\beta_{20} = (0, 1, 1, 1, 1, 1, 1)$ |
| $\beta_3 = (1, 2, 2, 4, 3, 2, 1)$ | $\beta_{12} = (1, 1, 2, 2, 2, 1, 1)$ | $\beta_{21} = (1, 0, 1, 1, 1, 1, 1)$ |
| $\beta_4 = (1, 2, 2, 3, 3, 2, 1)$ | $\beta_{13} = (0, 1, 1, 2, 2, 2, 1)$ | $\beta_{22} = (0, 0, 1, 1, 1, 1, 1)$ |
| $\beta_5 = (1, 1, 2, 3, 3, 2, 1)$ | $\beta_{14} = (1, 1, 1, 2, 2, 1, 1)$ | $\beta_{23} = (0, 1, 0, 1, 1, 1, 1)$ |
| $\beta_6 = (1, 2, 2, 3, 2, 2, 1)$ | $\beta_{15} = (1, 1, 2, 2, 1, 1, 1)$ | $\beta_{24} = (0, 0, 0, 1, 1, 1, 1)$ |
| $\beta_7 = (1, 1, 2, 3, 2, 2, 1)$ | $\beta_{16} = (0, 1, 1, 2, 2, 1, 1)$ | $\beta_{25} = (0, 0, 0, 0, 1, 1, 1)$ |
| $\beta_8 = (1, 2, 2, 3, 2, 1, 1)$ | $\beta_{17} = (1, 1, 1, 2, 1, 1, 1)$ | $\beta_{26} = (0, 0, 0, 0, 0, 1, 1)$ |
| $\beta_9 = (1, 1, 2, 2, 2, 2, 1)$ | $\beta_{18} = (0, 1, 1, 2, 1, 1, 1)$ | $\beta_{27} = (0, 0, 0, 0, 0, 0, 1)$ |

As in the E_6 -case the Hasse diagram has no k -chains. In addition there are only co-chains of cardinality at most 2, except for one with cardinality 3 (see Appendix, Figure 5). As before the polytope is defined by the paths in the Hasse diagram. For $m \in \mathbb{Z}_{\geq 0}$ we have:

$$P(m\omega) = \{\mathbf{x} \in \mathbb{R}_{\geq 0}^{27} \mid \sum_{\beta_j \in \mathbf{p}} x_j \leq m, \forall \mathbf{p} \in D_\omega\}.$$

Because the polytope is defined by 77 non-redundant inequalities we will not state it explicitly.

Proposition 4.6.1. *The set $\mathbb{B}_\omega = \{f^{\mathbf{s}}v_\omega \mid \mathbf{s} \in S(\omega)\}$ is a FFL basis of $V(\omega)$.*

Proof. The co-chains of the Hasse diagram give us immediately:

$$\mathbb{B}_\omega = \{v_\omega, f_1v_\omega, f_2v_\omega, \dots, f_{27}v_\omega, f_5f_6v_\omega, f_5f_8v_\omega, f_7f_8v_\omega, f_8f_9v_\omega, \\ f_9f_{10}v_\omega, f_8f_{11}v_\omega, f_{10}f_{11}v_\omega, f_{11}f_{12}v_\omega, f_8f_{13}v_\omega, f_{10}f_{13}v_\omega, \\ f_{12}f_{13}v_\omega, f_{13}f_{14}v_\omega, f_{11}f_{15}v_\omega, f_{13}f_{15}v_\omega, f_{14}f_{15}v_\omega, f_{15}f_{16}v_\omega, \\ f_{13}f_{17}v_\omega, f_{16}f_{17}v_\omega, f_{13}f_{19}v_\omega, f_{16}f_{19}v_\omega, f_{18}f_{19}v_\omega, f_{13}f_{21}v_\omega, \\ f_{16}f_{21}v_\omega, f_{18}f_{21}v_\omega, f_{20}f_{21}v_\omega, f_{21}f_{23}v_\omega, f_{22}f_{23}v_\omega, f_{13}f_{14}f_{15}v_\omega\}.$$

Note that there are 56 elements in \mathbb{B}_ω . By Corollary 3.1.5, we get that this is a spanning set of $V(\omega)$. By [Car05, p. 303] we have $\dim V(\omega) = 56$ and therefore that \mathbb{B}_ω is a basis. \square

4.7. **Type F_4 .** Let \mathfrak{g} be the simple Lie algebra of type F_4 with associated Dynkin diagram

$$F_4 \quad \circ_1 \text{---} \circ_2 \text{---} \circ_3 \text{---} \circ_4$$

The highest root is of the form $\theta = 2\alpha_1 + 3\alpha_2 + 4\alpha_4 + 2\alpha_3$. And we have $\theta^\vee = 2\alpha_1^\vee + 3\alpha_2^\vee + 2\alpha_3^\vee + \alpha_4^\vee$. So $\langle \omega, \theta^\vee \rangle = 1 \Leftrightarrow \omega = \omega_4$, so we consider the case $\omega = \omega_4$. If we construct $H(\mathfrak{n}_\omega^-)_{F_4}$ as in Section 1 we get a 3-chain of length 2, but here we are able to solve this problem. Therefore we will change the order of the roots such that we can draw a new diagram without any k -chains. As usual we start with the set of roots Δ_+^ω :

| | | |
|--------------------------|-----------------------------|-----------------------------|
| $\beta_1 = (2, 3, 4, 2)$ | $\beta_6 = (1, 2, 3, 1)$ | $\beta_{11} = (0, 1, 2, 1)$ |
| $\beta_2 = (1, 3, 4, 2)$ | $\beta_7 = (1, 1, 2, 2)$ | $\beta_{12} = (1, 1, 1, 1)$ |
| $\beta_3 = (1, 2, 4, 2)$ | $\beta_8 = (1, 2, 2, 1)$ | $\beta_{13} = (0, 1, 1, 1)$ |
| $\beta_4 = (1, 2, 3, 2)$ | $\beta_9 = (0, 1, 2, 2)$ | $\beta_{14} = (0, 0, 1, 1)$ |
| $\beta_5 = (1, 2, 2, 2)$ | $\beta_{10} = (1, 1, 2, 1)$ | $\beta_{15} = (0, 0, 0, 1)$ |

Here we have $\beta_i \succ \beta_j \Leftrightarrow i > j$. With this order we are not able to find relations derived from differential operators (see Section 3), which include the rootvector f_4 (see (3.2)). In order to find relations including f_4 we adjust the order on the roots in this case as follows:

$$\beta_1 \prec \beta_2 \prec \beta_3 \prec \beta_5 \prec \beta_4 \prec \beta_6 \prec \beta_7 \prec \dots \prec \beta_{15}.$$

So we just switched the positions of β_4 and β_5 . Now we consider our Hasse diagram constructed as in Section 1 and the diagram we obtain by changing the order of the roots and by using differential operators corresponding to non-simple roots, see Figure 1.

The idea of this adjustment is that we split up the 3-chain by using the non-simple differential operators mentioned above. After this we still want to get as many roots as possible on each path. To do so we use two non-simple differential operators: $\partial_{0110} = \partial_{\alpha_2+\alpha_3}$ and $\partial_{0011} = \partial_{\alpha_3+\alpha_4}$. In the adjusted diagram also occurs a directed edge labeled by \mathfrak{a} from β_2 to β_5 and a second labeled by \mathfrak{b} from β_5 to β_4 . We cannot label the second edge with a differential operator, because there is no element $\gamma \in \Delta_+$ satisfying: $\beta_5 - \gamma = \beta_4$. We will use the following observation to explain the existence of these edges and labels. For $a_0, b_0 \in \mathbb{C} \setminus \{0\}$ we have:

$$\begin{aligned} \partial_3^{n_2+2n_3} \partial_2^{n_2+n_3} \partial_1^{n_1} f_1^{m+1} &= \partial_3^{n_2+2n_3} (a_0 f_3^{n_2+n_3} f_2^{n_1-n_2-n_3} f_1^{m+1-n_1}) \\ &= b_0 f_5^{n_3} f_4^{n_2} f_2^{n_1-n_2-n_3} f_1^{m+1-n_1} + \text{smaller terms.} \end{aligned}$$

That means we can replace in the path consisting of $\beta_1, \beta_2, \beta_3$ and β_4 the root β_3 by β_5 . Furthermore the differential operators $\partial_{\alpha_2+\alpha_3}$ and $\partial_{\alpha_3+\alpha_4}$ have no influence on β_5 . That is the reason for the directed edge labeled by \mathfrak{b} from β_5 to β_4 . The reason for the edge between β_2 and β_5 is that we want to visualize the co-chain which we construct at this point. We label this edge with \mathfrak{a} to prevent confusions about the applied differential operators, where \mathfrak{a} corresponds to $\partial_3^{n_2+2n_3}$. We note that the changed Hasse diagram gives us directly the inequalities of $P(\lambda)$, but in this case it does not describe in general the action of the differential operators.

If we now follow our standard procedure with the adjusted Hasse diagram the next step is to define the polytope associated to the set of Dyck paths D_ω and $m \in \mathbb{Z}_{\geq 0}$:

$$P(m\omega) = \{\mathbf{x} \in \mathbb{R}_{\geq 0}^{15} \mid \sum_{\beta_j \in \mathbf{p}} x_j \leq m, \forall \mathbf{p} \in D_\omega\}.$$

More explicitly: $P(m\omega)$ is the set of all elements $\mathbf{x} \in \mathbb{R}_{\geq 0}^{15}$ such that the 12 inequalities, which can be found in the Appendix, Figure 5, are satisfied.

The set $\mathbb{B}_\omega = \{f^{\mathbf{s}}v_\omega \mid \mathbf{s} \in S(\omega)\} \subset V(\omega)$ is given by:

$$\mathbb{B}_\omega = \{v_\omega, f_1v_\omega, f_2v_\omega, \dots, f_{15}v_\omega, f_3f_5v_\omega, f_4f_6v_\omega, f_5f_6v_\omega, f_6f_7v_\omega, f_7f_8v_\omega, f_6f_9v_\omega, f_8f_9v_\omega, f_9f_{10}v_\omega, f_9f_{12}v_\omega, f_{11}f_{12}v_\omega\}.$$

Proposition 4.7.1. *The set $\mathbb{B}_\omega = \{f^{\mathbf{s}}v_\omega \mid \mathbf{s} \in S(\omega)\}$ is a FFL basis of $V(\omega)$.*

Proof. By Corollary 3.1.5 we conclude that \mathbb{B}_ω spans the vector space $V(\omega)$. In addition we know by [Car05, p. 303] that $\dim V(\omega) = 26 = |\mathbb{B}_\omega|$. Hence the set \mathbb{B}_ω is a basis. \square

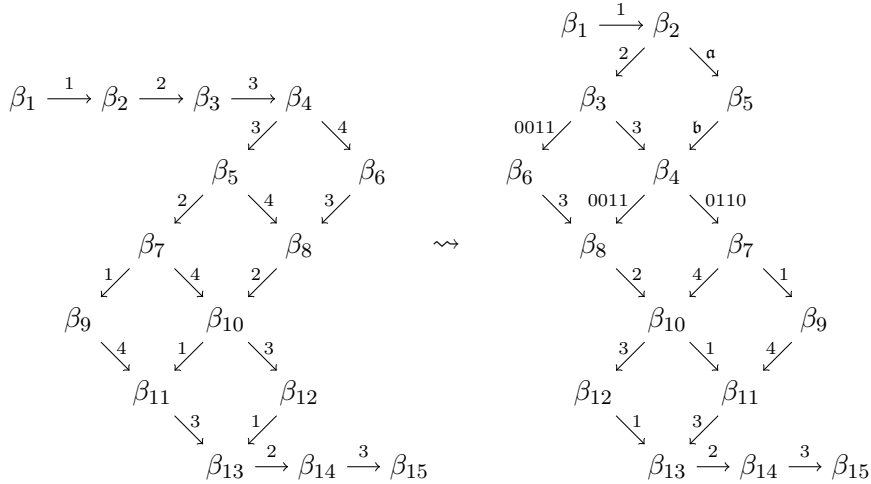

FIGURE 1. $H(\mathfrak{n}_\omega^-)_{\mathbb{F}_4}$

4.8. Type G_2 . Let \mathfrak{g} be the simple Lie algebra of type G_2 with associated Dynkin diagram

$$G_2 \quad \circ \rightleftarrows \circ \\ \quad \quad \quad 1 \quad \quad \quad 2$$

For the highest root $\theta = 3\alpha_1 + 2\alpha_2$ we have $\theta^\vee = \alpha_1^\vee + 2\alpha_2^\vee$. So we consider $\omega = \omega_1$. In this case the Hasse diagram has one 1-chain. We will rewrite $H(\mathfrak{n}_\omega^-)_{G_2}$ into a diagram without any k -chains. Consider the following order on Δ_+^ω :

$$\beta_1 \prec \beta_2 \prec \beta_4 \prec \beta_5 \prec \beta_3,$$

where

$$\boxed{\beta_1 = (3, 2) \mid \beta_2 = (3, 1) \mid \beta_3 = (2, 1) \mid \beta_4 = (1, 1) \mid \beta_5 = (1, 0)}$$

So we obtain the following diagrams:

$$\beta_1 \xrightarrow{2} \beta_2 \xrightarrow{1} \beta_3 \xrightarrow{1} \beta_4 \xrightarrow{2} \beta_5 \quad \rightsquigarrow \quad \begin{array}{ccccc} & & \beta_2 & & \\ & \nearrow 2 & & \searrow 2^1 & \\ \beta_1 & \xrightarrow{1^1} & \beta_3 & & \beta_5, \\ & \searrow 2^1 & & \nearrow 2 & \\ & & \beta_4 & & \end{array}$$

Very similar arguments as in the case of \mathbb{B}_3, ω_1 show that we can apply the results of section 3 to the rewritten diagram. We consider the polytope associated to the new diagram for $m \in \mathbb{Z}_{\geq 0}$:

$$P(m\omega) = \left\{ \mathbf{x} \in \mathbb{R}_{\geq 0}^N \mid \begin{array}{l} x_1 + x_2 + x_3 + x_5 \leq m \\ x_1 + x_3 + x_4 + x_5 \leq m \end{array} \right\}.$$

By Section 3 the elements $v_\omega, f_1v_\omega, f_2v_\omega, f_3v_\omega, f_4v_\omega, f_5v_\omega, f_2f_4v_\omega$ span $V(\omega)$ and with [Car05, p. 316] we know $\dim V(\omega) = 7$.

Proposition 4.8.1. *The set $\mathbb{B}_\omega = \{f^{\mathbf{s}}v_\omega \mid \mathbf{s} \in S(\omega)\}$ is a FFL basis of $V(\omega)$. \square*

Proof. The previous observations imply that $\{f^{\mathbf{s}}v_\omega \mid \mathbf{s} \in S(\omega)\}$ is a basis of $V(\omega)$. It remains to show that $P(\omega)$ is a normal polytope.

Like in the case of (\mathbb{B}_n, ω_1) we have to change the order of the roots to apply Section 2. One possible order is $\beta_1 \prec \beta_3 \prec \beta_4 \prec \beta_2 \prec \beta_5$. Using this order we conclude that $P(\omega)$ is a normal polytope. \square

5. LINEAR INDEPENDENCE

We refer to the notation of Section 1, especially Subsection 1.3. Throughout the Section we assume the vectors $f^{\mathbf{p}}v_\lambda \in V(\lambda)$ to be ordered as in (1.11) and we fix $\lambda = m\omega$ where ω appears in Table 2.

We want to investigate the connection between our polytope $P(\lambda)$ and the essential multi-exponents. Via this connection and with the results from Section 3 we want to prove that $\{f^{\mathbf{s}}v_\lambda \mid \mathbf{s} \in S(\lambda)\}$ provides a FFL basis of $V(\lambda)$.

Note that one can define essential monomials like in Subsection 1.3 for an arbitrary total order on Δ_+^λ . Hence for the following statements it is very important that we kept in Subsection 1.3 the total order introduced in Subsection 1.1.

Lemma 5.1.1. *If $\{f^{\mathbf{s}}v_\lambda \mid \mathbf{s} \in S(\lambda)\}$ is linear independent in $V(\lambda)$, then*

$$S(\lambda) = \text{es}(V(\lambda)).$$

Proof. Let $\mathbf{s} \in \text{es}(V(\lambda)) = \{\mathbf{p} \in \mathbb{Z}_{\geq 0}^N \mid f^{\mathbf{p}}v_\lambda \notin \text{span}\{f^{\mathbf{q}}v_\lambda \mid \mathbf{q} \prec \mathbf{p}\}\}$ and assume $\mathbf{s} \notin S(\lambda)$. By Proposition 3.1.3 we can rewrite $f^{\mathbf{s}}$ such that

$$f^{\mathbf{s}}v_\lambda = \sum_{\mathbf{t} \prec \mathbf{s}} c_{\mathbf{t}} f^{\mathbf{t}}v_\lambda, \quad c_{\mathbf{t}} \in \mathbb{C}$$

and we get immediately a contradiction, so $\mathbf{s} \in S(\lambda)$.

Now let $\mathbf{s} \in S(\lambda)$ and $\mathbf{s} \notin \text{es}(V(\lambda))$. Then $f^{\mathbf{s}}v_\lambda \in \text{span}\{f^{\mathbf{q}}v_\lambda \mid \mathbf{q} \prec \mathbf{s}\}$ and so

$$(5.1) \quad f^{\mathbf{s}}v_\lambda = \sum_{\mathbf{q} \prec \mathbf{s}} c_{\mathbf{q}} f^{\mathbf{q}}v_\lambda,$$

for some $c_{\mathbf{q}} \in \mathbb{C}$. We rewrite each $f^{\mathbf{q}}v_\lambda$ in terms of basis elements $f^{\mathbf{t}}v_\lambda, \mathbf{t} \in S(\lambda)$. Because of the linear independence all prefactors are zero, meaning that $\mathbf{s} = 0$. But this is a contradiction to $\mathbf{s} \notin \text{es}V(\lambda)$. \square

Theorem 5.1.2. *The elements $\{f^{\mathbf{s}}(v_{\lambda-\omega} \otimes v_{\omega}) \mid \mathbf{s} \in S(\lambda)\} \subset V(\lambda - \omega) \odot V(\omega)$ are linearly independent and $\mathbb{B}_{\lambda} = \{f^{\mathbf{s}}v_{\lambda} \mid \mathbf{s} \in S(\lambda)\}$ is a FFL basis of $V(\lambda)$.*

Proof. We want to prove this statement by induction on $m \in \mathbb{Z}_{\geq 1}$. For $m = 1$ we saw in Section 4 that $\mathbb{B}_{\omega} = \{f^{\mathbf{s}}v_{\omega} \mid \mathbf{s} \in S(\omega)\}$ is a basis for $V(\omega)$ in each type. So let $m \in \mathbb{Z}_{\geq 2}$ be arbitrary and we assume that the claim holds for all $m' < m$. By induction the set $\mathbb{B}_{\lambda-\omega} = \{f^{\mathbf{s}}v_{\lambda-\omega} \mid \mathbf{s} \in S(\lambda - \omega)\}$ is a basis of $V(\lambda - \omega)$. So we have by Lemma 5.1.1

$$(5.2) \quad \text{es}(V(\lambda - \omega)) = S(\lambda - \omega) \text{ and } \text{es}(V(\omega)) = S(\omega).$$

But then with [FFoL13, Prop. 1.11]:

$$\text{es}(V(\lambda - \omega) + \text{es}(V(\omega))) \subset \text{es}(V(\lambda - \omega) \odot V(\omega))$$

and so we get the linearly independence of

$$\{f^{\mathbf{s}}(v_{\lambda-\omega} \otimes v_{\omega}) \mid \mathbf{s} \in \text{es}(V(\lambda - \omega) + \text{es}(V(\omega)))\} \subset V(\lambda - \omega) \odot V(\omega)$$

With the equalities in (5.2) and Section 2 where we proved $S(\lambda - \omega) + S(\omega) = S(\lambda)$, we conclude that the set

$$\{f^{\mathbf{s}}(v_{\lambda-\omega} \otimes v_{\omega}) \mid \mathbf{s} \in S(\lambda)\} \subset V(\lambda - \omega) \odot V(\omega)$$

is linearly independent. So we get $\dim V(\lambda) \geq |S(\lambda)|$ and with the spanning property Corollary 3.1.5 we have $|S(\lambda)| \geq \dim V(\lambda)$. Finally we get

$$|S(\lambda)| = \dim V(\lambda)$$

and that \mathbb{B}_{λ} is a FFL basis of $V(\lambda)$ as claimed. \square

Remark 5.1.3. *The basis \mathbb{B}_{λ} is a monomial basis, so we get an induced FFL basis of $V(\lambda)^a$.*

Theorem 5.1.4. *Let $V(\lambda)^a \cong S(\mathfrak{n}^-)/I(\lambda)$. Then the ideal $I(\lambda)$ is generated by*

$$U(\mathfrak{n}^+) \circ \text{span}\{f_{\beta}^{(\lambda, \beta^{\vee})+1} \mid \beta \in \Delta_+\}$$

as $S(\mathfrak{n}^-)$ ideal.

In particular we have that $I(\lambda) = S(\mathfrak{n}^-)(U(\mathfrak{n}^+) \circ \text{span}\{f_{\beta}, f_{\theta}^{m+1} \mid \beta \in \Delta_+ \setminus \Delta_+^{\lambda}\})$.

Proof. Let I be an Ideal generated by $U(\mathfrak{n}^+) \circ \text{span}\{f_{\beta}^{(\lambda, \beta^{\vee})+1} \mid \beta \in \Delta_+\}$ as $S(\mathfrak{n}^-)$ ideal. By $Iv_{\lambda} = \{0\}$ we have $I \subset I(\lambda)$, so there is a canonical projection:

$$\phi : S(\mathfrak{n}^-)/I \rightarrow S(\mathfrak{n}^-)/I(\lambda) \cong V(\lambda)^a$$

Let $f^{\mathbf{t}} = 0$ in $S(\mathfrak{n}^-)/I(\lambda)$. Because we have a basis of $V(\lambda)^a$ we can rewrite $f^{\mathbf{t}}$ as follows:

$$(5.3) \quad f^{\mathbf{t}} = \sum_{\mathbf{s} \in S(\lambda)} c_{\mathbf{s}} f^{\mathbf{s}} \in S(\mathfrak{n}^-)/I(\lambda)$$

for some $c_{\mathbf{s}} \in \mathbb{C}$. In the proof of Theorem 3.1.4 we already saw that the relations obtained by I are sufficient to achieve (5.3). So $0 = f^{\mathbf{t}} = \sum_{\mathbf{s} \in S(\lambda)} c_{\mathbf{s}} f^{\mathbf{s}} \in S(\mathfrak{n}^-)/I$.

Therefore ϕ is injective.

In the proof of Proposition 3.1.3 we do not need powers f_{β} for $\beta \in \Delta_+^{\lambda} \setminus \{\theta\}$. \square

APPENDIX

In this section we want to present the Hasse diagrams $H(\mathfrak{n}_{\omega_6}^-)_{\mathbf{E}_6}$ and $H(\mathfrak{n}_{\omega_7}^-)_{\mathbf{E}_7}$ for a better understanding of our work. In addition to illustrate the ordering of the roots for the classical types \mathbf{A}_n , \mathbf{B}_n and \mathbf{D}_n we give in Figure 2 the complete Hasse diagram of \mathfrak{sl}_5 and in Figure 3 a concrete example of the Hasse diagram in the \mathbf{D}_n , ω_n -case, for $n = 5, 6$. We remark that the shape of the Hasse diagram $H(\mathfrak{n}_{\omega_{n-1}}^-)_{\mathfrak{so}_{2n}}$ and $H(\mathfrak{n}_{\omega_n}^-)_{\mathfrak{so}_{2n}}$ is equal to the shape of $H(\mathfrak{n}_{\omega_{n-1}}^-)_{\mathfrak{so}_{2(n-1)+1}}$. So Figure 3 shows also the shape of the Hasse diagrams $H(\mathfrak{n}_{\omega_4}^-)_{\mathfrak{so}_{10}}$, $H(\mathfrak{n}_{\omega_5}^-)_{\mathfrak{so}_{10}}$ and $H(\mathfrak{n}_{\omega_5}^-)_{\mathfrak{so}_{12}}$, $H(\mathfrak{n}_{\omega_6}^-)_{\mathfrak{so}_{12}}$. Furthermore we state the explicit polytopes for \mathbf{E}_6 (Table 4), \mathbf{F}_4 (Table 5) and for the special cases: \mathbf{B}_4 , ω_4 (\mathbf{D}_5 , ω_4) and \mathbf{D}_5 ω_5 (Table 3).

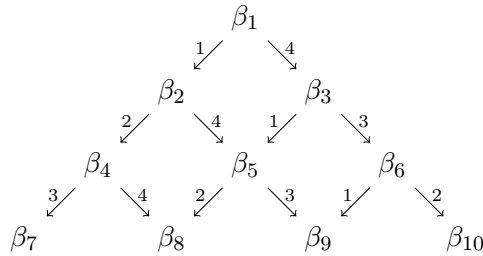

FIGURE 2. Complete Hasse diagram of $\mathfrak{g} = \mathfrak{sl}_5$.

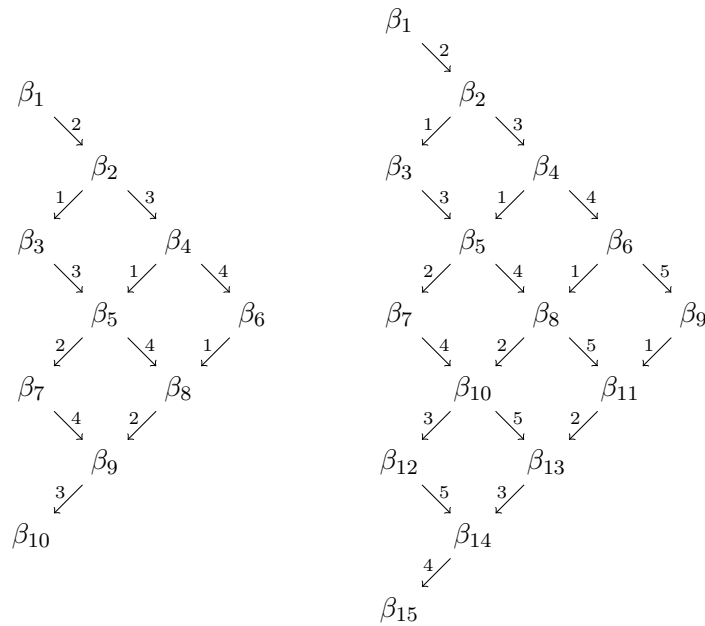

FIGURE 3. $H(\mathfrak{n}_{\omega_4}^-)_{\mathfrak{so}_9}$, $H(\mathfrak{n}_{\omega_5}^-)_{\mathfrak{so}_{11}}$

$$\begin{aligned}
x_1 + x_2 + x_3 + x_5 + x_7 + x_9 + x_{10} &\leq m \\
x_1 + x_2 + x_3 + x_5 + x_8 + x_9 + x_{10} &\leq m \\
x_1 + x_2 + x_4 + x_5 + x_7 + x_9 + x_{10} &\leq m \\
x_1 + x_2 + x_4 + x_5 + x_8 + x_9 + x_{10} &\leq m \\
x_1 + x_2 + x_4 + x_6 + x_8 + x_9 + x_{10} &\leq m
\end{aligned}$$

TABLE 3. Polytope $P(m\omega_4)$ corresponding to $\mathfrak{g} = \mathfrak{so}_9$ and $P(m\omega_4)$, $P(m\omega_5)$ corresponding to $\mathfrak{g} = \mathfrak{so}_{10}$.

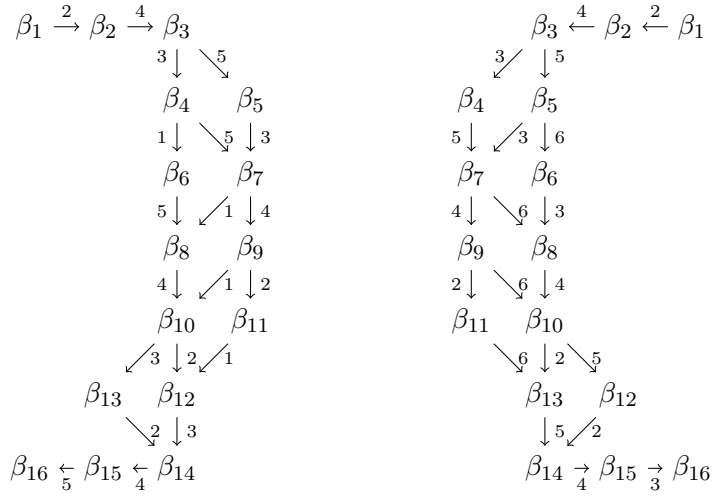

FIGURE 4. $H(\mathfrak{n}_{\omega_6}^-)_{E_6}$ and $H(\mathfrak{n}_{\omega_1}^-)_{E_6}$

$$\begin{aligned}
x_1 + x_2 + x_3 + x_4 + x_6 + x_8 + x_{10} + x_{13} + x_{14} + x_{15} + x_{16} &\leq m \\
x_1 + x_2 + x_3 + x_4 + x_6 + x_8 + x_{10} + x_{12} + x_{14} + x_{15} + x_{16} &\leq m \\
x_1 + x_2 + x_3 + x_4 + x_7 + x_8 + x_{10} + x_{13} + x_{14} + x_{15} + x_{16} &\leq m \\
x_1 + x_2 + x_3 + x_4 + x_7 + x_8 + x_{10} + x_{12} + x_{14} + x_{15} + x_{16} &\leq m \\
x_1 + x_2 + x_3 + x_4 + x_7 + x_9 + x_{10} + x_{13} + x_{14} + x_{15} + x_{16} &\leq m \\
x_1 + x_2 + x_3 + x_4 + x_7 + x_9 + x_{10} + x_{12} + x_{14} + x_{15} + x_{16} &\leq m \\
x_1 + x_2 + x_3 + x_4 + x_7 + x_9 + x_{11} + x_{12} + x_{14} + x_{15} + x_{16} &\leq m \\
x_1 + x_2 + x_3 + x_5 + x_7 + x_8 + x_{10} + x_{13} + x_{14} + x_{15} + x_{16} &\leq m \\
x_1 + x_2 + x_3 + x_5 + x_7 + x_8 + x_{10} + x_{12} + x_{14} + x_{15} + x_{16} &\leq m \\
x_1 + x_2 + x_3 + x_5 + x_7 + x_9 + x_{10} + x_{13} + x_{14} + x_{15} + x_{16} &\leq m \\
x_1 + x_2 + x_3 + x_5 + x_7 + x_9 + x_{10} + x_{12} + x_{14} + x_{15} + x_{16} &\leq m \\
x_1 + x_2 + x_3 + x_5 + x_7 + x_9 + x_{11} + x_{12} + x_{14} + x_{15} + x_{16} &\leq m
\end{aligned}$$

TABLE 4. Polytope $P(m)$ corresponding to E_6

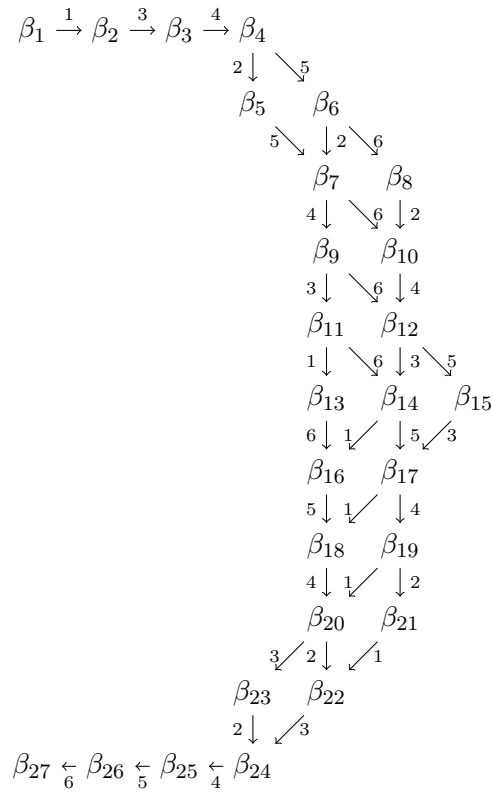

FIGURE 5. $H(\mathfrak{n}_{\omega_7}^-)_{E_7}$

| | |
|--|----------|
| $x_1 + x_2 + x_3 + x_4 + x_8 + x_{10} + x_{11} + x_{13} + x_{14} + x_{15}$ | $\leq m$ |
| $x_1 + x_2 + x_3 + x_4 + x_8 + x_{10} + x_{12} + x_{13} + x_{14} + x_{15}$ | $\leq m$ |
| $x_1 + x_2 + x_3 + x_4 + x_7 + x_9 + x_{11} + x_{13} + x_{14} + x_{15}$ | $\leq m$ |
| $x_1 + x_2 + x_3 + x_4 + x_7 + x_{10} + x_{11} + x_{13} + x_{14} + x_{15}$ | $\leq m$ |
| $x_1 + x_2 + x_3 + x_4 + x_7 + x_{10} + x_{12} + x_{13} + x_{14} + x_{15}$ | $\leq m$ |
| $x_1 + x_2 + x_4 + x_5 + x_8 + x_{10} + x_{11} + x_{13} + x_{14} + x_{15}$ | $\leq m$ |
| $x_1 + x_2 + x_4 + x_5 + x_8 + x_{10} + x_{12} + x_{13} + x_{14} + x_{15}$ | $\leq m$ |
| $x_1 + x_2 + x_4 + x_5 + x_7 + x_9 + x_{11} + x_{13} + x_{14} + x_{15}$ | $\leq m$ |
| $x_1 + x_2 + x_4 + x_5 + x_7 + x_{10} + x_{11} + x_{13} + x_{14} + x_{15}$ | $\leq m$ |
| $x_1 + x_2 + x_4 + x_5 + x_7 + x_{10} + x_{12} + x_{13} + x_{14} + x_{15}$ | $\leq m$ |
| $x_1 + x_2 + x_3 + x_6 + x_8 + x_{10} + x_{11} + x_{13} + x_{14} + x_{15}$ | $\leq m$ |
| $x_1 + x_2 + x_3 + x_6 + x_8 + x_{10} + x_{12} + x_{13} + x_{14} + x_{15}$ | $\leq m$ |

TABLE 5. Polytope $P(m\omega_4)$ corresponding to F_4

ACKNOWLEDGMENTS

We are grateful to Ghislain Fourier, Deniz Kus and Peter Littelmann for very inspiring discussions. For many calculations on our polytopes we used the program LattE. We thank the developers.

The work of T. B. was funded by the DFG Priority Program SPP 1388 "Representation Theory", C.D. was partially funded by this program.

REFERENCES

- [ABS11] F. Ardila, T. Bliem, and D. Salazar. Gelfand-Tsetlin polytopes and Feigin-Fourier-Littelmann-Vinberg polytopes as marked poset polytopes. *Journal of Combinatorial Theory, Series A*, 118(8):2454 – 2462, 2011.
- [BBDF14] T. Backhaus, L. Bossinger, C. Desczyk, and G. Fourier. The degree of the Hilbert-Poincaré polynomial of PBW-graded modules. *Comptes Rendus Mathématique*, 352(12):959 – 963, 2014.
- [Car05] R. W. Carter. *Lie algebras of finite and affine type*, volume 96 of *Cambridge Studies in Advanced Mathematics*. Cambridge University Press, Cambridge, 2005.
- [CF13] M. Cherednik and E. Feigin. Extremal part of the PBW filtration and E-polynomials. arXiv:1306.3146, 2013.
- [CIFR12] G. Cerulli Irelli, E. Feigin, and M. Reineke. Quiver Grassmannians and degenerate flag varieties. *Algebra Number Theory*, 6(1):165–194, 2012.
- [CIL14] G. Cerulli Irelli and M. Lanini. Degenerate flag varieties of type A and C are Schubert varieties. arXiv:1403.2889, 2014.
- [CLaL14] G. Cerulli Irelli, M. Lanini, and P. Littelmann. Degenerate flag varieties and Schubert varieties. preprint.
- [Fei11] Evgeny Feigin. Degenerate flag varieties and the median Genocchi numbers. *Math. Res. Lett.*, 18(6):1163–1178, 2011.
- [Fei12] Evgeny Feigin. \mathbb{G}_a^M degeneration of flag varieties. *Selecta Math. (N.S.)*, 18(3):513–537, 2012.
- [FFiL11] E. Feigin, M. Finkelberg, and P. Littelmann. Symplectic degenerate flag varieties. arXiv:1106.1399, 2011.
- [FFoL11a] E. Feigin, G. Fourier, and P. Littelmann. PBW filtration and bases for irreducible modules in type A_n . *Transform. Groups*, 16(1):71–89, 2011.
- [FFoL11b] E. Feigin, G. Fourier, and P. Littelmann. PBW filtration and bases for symplectic Lie algebras. *Int. Math. Res. Not. IMRN*, 1(24):5760–5784, 2011.
- [FFoL13] E. Feigin, G. Fourier, and P. Littelmann. Favourable modules: Filtrations, polytopes, Newton-Okounkov bodies and flat degenerations. arXiv:1306.1292v3, 2013.
- [FM14] E. Feigin and I. Makedonskyi. Nonsymmetric Macdonald polynomials, Demazure modules and PBW filtration. arXiv:1407.6316, 2014.
- [Fou14] Ghislain Fourier. New homogeneous ideals for current algebras: filtrations, fusion products and Pieri rules. arXiv:1403.4758, 2014.
- [GL97] N. Gonciulea and V. Lakshmibai. Schubert varieties, toric varieties, and ladder determinantal varieties. *Ann. Inst. Fourier (Grenoble)*, 47(4):1013–1064, 1997.
- [Gor11] A. Gornitsky. Essential signatures and canonical bases in irreducible representations of the group G_2 . Diploma thesis, 2011, 2011.
- [Hag13] Chuck Hague. Degenerate coordinate rings of flag varieties and Frobenius splitting. arXiv:1307.7634, 2013.
- [HK13] M. Harada and K. Kaveh. Integrable systems, toric degenerations and Okounkov bodies. arXiv:1205.5249, 2013.
- [Hum72] James E. Humphreys. *Introduction to Lie algebras and representation theory*. Springer-Verlag, New York, 1972. Graduate Texts in Mathematics, Vol. 9.
- [KK12] K. Kaveh and A. G. Khovanskii. Newton-Okounkov bodies, semigroups of integral points, graded algebras and intersection theory. *Ann. of Math. (2)*, 176(2):925–978, 2012.
- [KM05] M. Kogan and E. Miller. Toric degeneration of Schubert varieties and Gelfand-Tsetlin polytopes. *Adv. Math.*, 193(1):1–17, 2005.

- [Kus13a] Deniz Kus. Kirillov-Reshetikhin crystals, energy function and the combinatorial R-matrix. arXiv:1309.6522, 2013.
- [Kus13b] Deniz Kus. Realization of affine type A Kirillov-Reshetikhin crystals via polytopes. *J. Combin. Theory Ser. A*, 120(8):2093–2117, 2013.
- [V05] Ernest Vinberg. On some canonical bases of representation spaces of simple Lie algebras. Conference talk, Bielefeld, 2005.

MATHEMATISCHES INSTITUT, UNIVERSITÄT ZU KÖLN,
WEYERTAL 86-90, D-50931 KÖLN, GERMANY
E-mail address: `tbackha@math.uni-koeln.de`
E-mail address: `cdesczyk@math.uni-koeln.de`

4. THE PBW FILTRATION AND CONVEX POLYTOPES IN TYPE B

TEODOR BACKHAUS AND DENIZ KUS

ABSTRACT. We study the PBW filtration on irreducible finite-dimensional representations for the Lie algebra of type B_n . We prove in various cases, including all multiples of the adjoint representation and all irreducible finite-dimensional representations for B_3 , that there exists a normal polytope such that the lattice points of this polytope parametrize a basis of the corresponding associated graded space. As a consequence we obtain several classes of examples for favourable modules and graded combinatorial character formulas.

1. INTRODUCTION

Let \mathfrak{g} be a complex finite-dimensional simple Lie algebra with highest root θ . The PBW filtration on finite-dimensional irreducible representations of \mathfrak{g} was studied in [13] and a description of the associated graded space in terms of generators and relations has been given in type A_n and C_n (see [13, 14]). As a beautiful consequence the authors obtained a new class of bases parametrized by the lattice points of normal polytopes, which we call the FFL polytopes. A new class of bases for type G_2 is established in [16] by using different arguments.

It turned out that the PBW theory has a lot of connections to many areas of representation theory. For example, in the branch of combinatorial representation theory the FFL polytopes can be used to provide models for Kirillov–Reshetikhin crystals (see [19, 20]). Further, a purely combinatorial research shows that there exists an explicit bijection between FFL polytopes and the well-known (generalized) Gelfand–Tsetlin polytopes (see [1, Theorem 1.3]). Although Berenstein and Zelevinsky defined the B_n -analogue of Gelfand–Tsetlin polytopes in [4] it is much more complicated to define the B_n -analogue of FFL polytopes (see [1, Section 4]). One of the motivations of the present paper is to better understand (the difficulties of) the PBW filtration in this type.

In the branch of geometric representation theory the PBW filtration can be used to study flat degenerations of generalized flag varieties. The degenerate flag variety of type A_n and C_n respectively can be realized inside a product of Grassmanians (see [8, Theorem 2.5] and [11, Theorem 1.1]) and furthermore the degenerate flag variety is isomorphic to an appropriate Schubert variety (see [17, Theorem 1.1]). Another powerful tool of studying these varieties are favourable modules, where the properties of a favourable module are governed by the combinatorics of an associated normal polytope (see for details [12] or Section 6). It has been proved in [12] that the degenerate flag varieties associated to favourable modules have nice properties. For example, they are normal and Cohen–Macaulay and, moreover, the underlying polytope can be interpreted as the Newton–Okounkov body for the flag variety. In the same paper several classes of examples for favourable modules of type A_n , C_n and G_2 respectively are provided; more classes of examples were constructed in [2, 5, 15].

Beyond these cases very little is known about the PBW filtration and whether there exists a normal polytope parametrizing a PBW basis of the associated graded space. This paper is motivated by proving the existence of such polytopes for several classes of representations of type B_n . Moreover,

T.B. was funded by the DFG Priority Program SPP 1388 Representation theory.

D.K. was partially supported by the SFB/TR 12-Symmetries and Universality in Mesoscopic Systems.

we construct favourable modules (see Section 6) and use the results of [16] to describe the associated graded space for type \mathbf{G}_2 in terms of generators and relations (see Section 7).

If $n \leq 3$ we obtain similar results as in the aforementioned cases, namely we associate to any dominant integral weight λ a normal polytope and prove that a basis of the associated graded space can be parametrized by the lattice points of this polytope. In other words we observe that the difficulties of the PBW theory show up if $n \geq 4$. Our results are the following; see Section 5 for the precise definitions.

Theorem. Let \mathfrak{g} be the Lie algebra of type \mathbf{B}_3 . There is a normal polytope $P(\lambda)$ with the following properties:

- (1) The lattice points $S(\lambda)$ parametrize a basis of $V(\lambda)$ and $\text{gr } V(\lambda)$ respectively. In particular,

$$\{X^{\mathbf{s}} v_\lambda \mid \mathbf{s} \in S(\lambda)\}$$

forms a basis of $\text{gr } V(\lambda)$.

- (2) We have

$$S(\lambda) + S(\mu) = S(\lambda + \mu).$$

- (3) The character and graded q -character respectively is given by

$$\text{ch } V(\lambda) = \sum_{\mu \in \mathfrak{h}^*} |S(\lambda)^\mu| e^\mu, \quad \text{ch}_q \text{gr } V(\lambda) = \sum_{\mathbf{s} \in S(\lambda)} e^{\lambda - \text{wt}(\mathbf{s})} q^{\sum s_\beta}.$$

- (4) We have an isomorphism of $S(\mathfrak{n}^-)$ -modules

$$\text{gr } V(\lambda + \mu) \cong S(\mathfrak{n}^-)(v_\lambda \otimes v_\mu) \subseteq \text{gr } V(\lambda) \otimes \text{gr } V(\mu).$$

- (5) The module $V(\lambda)$ is favourable.

As in the cases \mathbf{A}_n , \mathbf{C}_n and \mathbf{G}_2 point (2) of the above theorem implies that the building blocks are $S(\omega_i)$, $1 \leq i \leq n$. In particular, in order to construct a basis for $\text{gr } V(\lambda)$ it will be enough to construct the polytopes $P(\omega_i)$ associated to fundamental weights. For type \mathbf{B}_n and $n \geq 4$ we need a different approach. For example, for $n = 4$ we construct a polytope $P(\omega_3)$ such that the lattice points $S(\omega_3)$ parametrize a basis of $\text{gr } V(\omega_3)$, but the Minkowski-sum $S(\omega_3) + S(\omega_3)$ has cardinality $\dim V(2\omega_3) - 1$. We observe that the building blocks in this case are $S(\omega_3)$ and $S(2\omega_3)$. In particular, we construct polytopes $P(\omega_3)$ and $P(2\omega_3)$ such that a basis of $\text{gr } V(m\omega_3)$ is given by

$$S(2\omega_3) + \cdots + S(2\omega_3) + \delta_{(m \bmod 2), 1} S(\omega_3),$$

where $\delta_{r,s}$ denotes Kronecker's delta symbol. Our results are the following; we refer to Section 4 and Section 6 for the precise definition of the ingredients.

Theorem. Let \mathfrak{g} be the Lie algebra of type \mathbf{B}_n and $\lambda = m\omega_i$ be a rectangular highest weight. There is a convex polytope $P(\lambda)$ such that: if $1 \leq i \leq 3$ (n arbitrary) or $1 \leq n \leq 4$ (i arbitrary) we have

- (1) The lattice points $S(\lambda)$ parametrize a basis of $V(\lambda)$ and $\text{gr } V(\lambda)$ respectively. In particular,

$$\{X^{\mathbf{s}} v_\lambda \mid \mathbf{s} \in S(\lambda)\}$$

forms a basis of $\text{gr } V(\lambda)$.

- (2) We have $\text{gr } V(\lambda) \cong S(\mathfrak{n}^-)/\mathbf{I}_\lambda$, where

$$\mathbf{I}_\lambda = S(\mathfrak{n}^-) \left(\mathbf{U}(\mathfrak{n}^+) \circ \text{span} \{x_{-\beta}^{\lambda(\beta^\vee)+1} \mid \beta \in R^+\} \right).$$

(3) The character and graded q -character respectively is given by

$$\text{ch } V(\lambda) = \sum_{\mu \in \mathfrak{h}^*} |S(\lambda)^\mu| e^\mu, \quad \text{ch}_q \text{gr } V(\lambda) = \sum_{\mathbf{s} \in S(\lambda)} e^{\lambda - \text{wt}(\mathbf{s})} q^{\sum s_\beta}.$$

(4) We have an isomorphism of $S(\mathfrak{n}^-)$ -modules for all $\ell \in \mathbb{Z}_+$:

$$\text{gr } V(\lambda + \epsilon_i \ell \omega_i) \cong S(\mathfrak{n}^-)(v_\lambda \otimes v_{\epsilon_i \ell \omega_i}) \subseteq \text{gr } V(\lambda) \otimes \text{gr } V(\epsilon_i \ell \omega_i),$$

where $\epsilon_i = 1$ if $i \leq 2$ and $\epsilon_i = 2$ else.

(5) For all $k, \ell \in \mathbb{Z}_+$ we have

$$S((k + \epsilon_i \ell) \omega_i) = S(k \omega_i) + S(\epsilon_i \ell \omega_i).$$

(6) The module $V(\epsilon_i \lambda)$ is favourable.

We can show in general that $S(\lambda)$ parametrizes a generating set of $\text{gr } V(\lambda)$ and we conjecture that the above theorem remains true for arbitrary rectangular weights (see Conjecture 4.3). We verified the cases $n \leq 8$ and $m \leq 9$ with a computer program.

Our paper is organized as follows: In Section 2 we give the main notations. In Section 3 we present the PBW filtration and establish the elementary results needed in the rest of the paper. In Section 4 we introduce the notion of Dyck paths for the special odd orthogonal Lie algebra and prove in various cases a presentation for the associated graded space. In Section 5 we associate to any dominant integral weight for \mathfrak{B}_3 a normal polytope parametrizing a basis of the associated graded space. In Section 6 we give classes of examples for favourable modules.

2. PRELIMINARIES

We denote the set of complex numbers by \mathbb{C} and, respectively, the set of integers, non-negative integers, and positive integers by \mathbb{Z} , \mathbb{Z}_+ , and \mathbb{N} . Unless otherwise stated, all the vector spaces considered in this paper are \mathbb{C} -vector spaces and \otimes stands for $\otimes_{\mathbb{C}}$.

2.1. We refer to [7, 18] for the general theory of Lie algebras. We denote by \mathfrak{g} a complex finite-dimensional simple Lie algebra. We fix a Cartan subalgebra \mathfrak{h} of \mathfrak{g} and denote by R the set of roots of \mathfrak{g} with respect to \mathfrak{h} . For $\alpha \in R$ we denote by α^\vee its coroot. We fix $\Delta = \{\alpha_1, \dots, \alpha_n\}$ a basis for R ; the corresponding sets of positive and negative roots are denoted as usual by R^\pm . For $1 \leq i \leq n$, define $\omega_i \in \mathfrak{h}^*$ by $\omega_i(\alpha_j^\vee) = \delta_{i,j}$, for $1 \leq j \leq n$, where $\delta_{i,j}$ is the Kronecker's delta symbol. The element ω_i is the fundamental weight of \mathfrak{g} corresponding to the coroot α_i^\vee . Let $Q = \bigoplus_{i=1}^n \mathbb{Z} \alpha_i$ be the root lattice of R and $Q^+ = \bigoplus_{i=1}^n \mathbb{Z}_+ \alpha_i$ be the respective \mathbb{Z}_+ -cone. The weight lattice of R is denoted by P and the cone of dominant weights is denoted by P^+ . Let $\mathbb{Z}[P]$ be the integral group ring of P with basis $e^\mu, \mu \in P$. Let W be the Weyl group of \mathfrak{g} .

2.2. Given $\alpha \in R^+$ let $\mathfrak{g}_{\pm\alpha}$ be the corresponding root space and fix a generator $x_{\pm\alpha} \in \mathfrak{g}_{\pm\alpha}$. We define several subalgebras of \mathfrak{g} that will be needed later. Let \mathfrak{b} be the Borel subalgebra corresponding to R^+ , and let \mathfrak{n}^+ be its nilpotent radical,

$$\mathfrak{b} = \mathfrak{h} \oplus \mathfrak{n}^+, \quad \mathfrak{n}^\pm = \bigoplus_{\alpha \in R^+} \mathfrak{g}_{\pm\alpha}.$$

The Lie algebra \mathfrak{g} has a triangular decomposition

$$\mathfrak{g} = \mathfrak{n}^- \oplus \mathfrak{h} \oplus \mathfrak{n}^+.$$

For a subset $\Delta - \{\alpha_{i_1}, \dots, \alpha_{i_s}\}$ of Δ we denote by $\mathfrak{p}_{i_1, \dots, i_s}$ the corresponding parabolic subalgebra of \mathfrak{g} , i.e. the Lie algebra generated by \mathfrak{b} and all root spaces $\mathfrak{g}_{-\alpha}$, $\alpha \in \Delta - \{\alpha_{i_1}, \dots, \alpha_{i_s}\}$. The

maximal parabolic subalgebras correspond to subsets of the form $\Delta - \{\alpha_i\}$, $1 \leq i \leq n$. The Lie algebra \mathfrak{g} contains the parabolic subalgebra as a direct summand and therefore

$$\mathfrak{g} = \mathfrak{p}_{i_1, \dots, i_s} \oplus \mathfrak{n}_{i_1, \dots, i_s}^-.$$

We can split off $\mathfrak{p}_{i_1, \dots, i_s}$ and consider the nilpotent vector space complement with root space decomposition

$$\mathfrak{n}_{i_1, \dots, i_s}^- = \bigoplus_{\alpha \in R_{i_1, \dots, i_s}^+} \mathfrak{g}_{-\alpha}.$$

For instance, if \mathfrak{g} is of type A_n we have $R^+ = \{\alpha_{r,s} \mid 1 \leq r \leq s \leq n\}$ and $R_i^+ = \{\alpha_{r,s} \in R^+ \mid r \leq i \leq s\}$ where $\alpha_{r,s} = \sum_{j=r}^s \alpha_j$. In the following we shall be interested in maximal parabolic subalgebras.

3. PBW FILTRATION AND GRADED SPACES

We start by recalling some standard notation and results on the representation theory of \mathfrak{g} .

3.1. A \mathfrak{g} -module V is said to be a weight module if it is \mathfrak{h} -semisimple,

$$V = \bigoplus_{\mu \in \mathfrak{h}^*} V^\mu, \quad V^\mu = \{v \in V \mid hv = \mu(h)v, \quad h \in \mathfrak{h}\}.$$

Set $\text{wt } V = \{\mu \in \mathfrak{h}^* : V^\mu \neq 0\}$. Given $\lambda \in P^+$, let $V(\lambda)$ be the irreducible finite-dimensional \mathfrak{g} -module generated by an element v_λ with defining relations:

$$\mathfrak{n}^+ v_\lambda = 0, \quad hv_\lambda = \lambda(h)v_\lambda, \quad x_{-\alpha}^{\lambda(\alpha^\vee)+1} v_\lambda = 0, \quad (3.1)$$

for all $h \in \mathfrak{h}$ and $\alpha \in R^+$. We have $\text{wt } V(\lambda) \subset \lambda - Q^+$ and $\text{wt } V(\lambda)$ is a W -invariant subset of \mathfrak{h}^* . If $\dim V^\mu < \infty$ for all $\mu \in \text{wt } V$, then we define $\text{ch } V : \mathfrak{h}^* \rightarrow \mathbb{Z}_+$, by sending $\mu \mapsto \dim V^\mu$. If $\text{wt } V$ is a finite set, then

$$\text{ch } V = \sum_{\mu \in \mathfrak{h}^*} \dim V^\mu e^\mu \in \mathbb{Z}[P].$$

3.2. A \mathbb{Z}_+ -filtration of a vector space V is a collection of subspaces $\mathbf{F} = \{V_s\}_{s \in \mathbb{Z}_+}$, such that $V_{s-1} \subseteq V_s$ for all $s \geq 1$. We build the associated graded space with respect to the filtration \mathbf{F}

$$\text{gr}^{\mathbf{F}} V = \bigoplus_{s \in \mathbb{Z}_+} V_s / V_{s-1}, \quad \text{where } V_{-1} = 0.$$

In this paper we shall be interested in the PBW filtration of the irreducible module $V(\lambda)$ which we will explain now. Consider the increasing degree filtration on the universal enveloping algebra $\mathbf{U}(\mathfrak{n}^-)$:

$$\mathbf{U}(\mathfrak{n}^-)_s = \text{span}\{x_1 \cdots x_l \mid x_j \in \mathfrak{n}^-, l \leq s\},$$

for example, $\mathbf{U}(\mathfrak{n}^-)_0 = \mathbb{C}$. The induced increasing filtration $\mathbf{V} = \{V(\lambda)_s\}_{s \in \mathbb{Z}_+}$ on $V(\lambda)$ where $V(\lambda)_s := \mathbf{U}(\mathfrak{n}^-)_s v_\lambda$ is called the PBW filtration. With respect to the PBW filtration we build the associated graded space $\text{gr}^{\mathbf{V}} V(\lambda)$ as above. To keep the notation as simple as possible, we will write $\text{gr } V(\lambda)$ to refer to $\text{gr}^{\mathbf{V}} V(\lambda)$. The graded q -character is defined as

$$\text{ch}_q \text{gr } V(\lambda) = \sum_{\mu \in \mathfrak{h}^*} \left(\sum_{s \geq 0} (\dim V(\lambda)_s^\mu / V(\lambda)_{s-1}^\mu) q^s \right) e^\mu, \quad \text{where } \text{gr } V(\lambda)^\mu = \bigoplus_{s \in \mathbb{Z}_+} V(\lambda)_s^\mu / V(\lambda)_{s-1}^\mu.$$

The following is immediate:

Lemma. The action of $\mathbf{U}(\mathfrak{n}^-)$ on $V(\lambda)$ induces a structure of a $S(\mathfrak{n}^-)$ module on $\text{gr } V(\lambda)$. Moreover,

$$\text{gr } V(\lambda) = S(\mathfrak{n}^-)v_\lambda \cong S(\mathfrak{n}^-)/\mathbf{I}_\lambda,$$

for some homogeneous Ideal \mathbf{I}_λ . The action of $\mathbf{U}(\mathfrak{n}^+)$ on $V(\lambda)$ induces a structure of a $\mathbf{U}(\mathfrak{n}^+)$ module on $\text{gr } V(\lambda)$.

By the previous lemma, the representation $\text{gr } V(\lambda)$ is cyclic as a $S(\mathfrak{n}^-)$ -module. By the PBW theorem and the defining relations (3.1) of $V(\lambda)$ we obtain the following proposition.

Proposition. The set

$$\left\{ \prod_{\beta \in R^+} x_{-\beta}^{m_\beta} v_\lambda \mid m_\beta \in \mathbb{Z}_+, m_\beta \leq \lambda(\beta^\vee) \right\}$$

is a (finite) spanning set of $\text{gr } V(\lambda)$.

For a multi-exponent $\mathbf{s} = (s_\beta)_{\beta \in R^+} \in \mathbb{Z}_+^{|R^+|}$ (resp. $\mathbf{s} = (s_\beta)_{\beta \in R_i^+} \in \mathbb{Z}_+^{|R_i^+|}$) we denote the corresponding monomial $\prod_{\beta \in R^+} x_{-\beta}^{s_\beta}$ (resp. $\prod_{\beta \in R_i^+} x_{-\beta}^{s_\beta}$) for simplicity by $X^{\mathbf{s}} \in S(\mathfrak{n}^-)$.

In recent years it became a popular goal to determine the $S(\mathfrak{n}^-)$ -structure of the representations $\text{gr } V(\lambda)$, i.e. to describe the ideals \mathbf{I}_λ and furthermore to find a PBW basis for these graded representations, favourably parametrized by the integral points of a suitable convex polytope. For the finite-dimensional Lie algebras of type \mathbf{A}_n , \mathbf{C}_n and \mathbf{G}_2 various results are known which we will discuss later (see [13, 14, 16]). The focus of this paper is on the Lie algebra of type \mathbf{B}_n where many technical difficulties show up.

3.3. Let $\mathbf{D} \subseteq \mathcal{P}(R^+)$ be a subset of the power set of R^+ . We attach to each element $\mathbf{p} \in \mathbf{D}$ a non-negative integer $M_{\mathbf{p}}(\lambda)$. We consider the following polytope

$$P(\mathbf{D}, \lambda) = \left\{ \mathbf{s} = (s_\beta)_{\beta \in R^+} \in \mathbb{R}_+^{|R^+|} \mid \forall \mathbf{p} \in \mathbf{D} : \sum_{\beta \in \mathbf{p}} s_\beta \leq M_{\mathbf{p}}(\lambda) \right\}. \quad (3.2)$$

The integral points of the above polytope are denoted by $S(\mathbf{D}, \lambda)$. The proof of part (i) of the following theorem for type \mathbf{A}_n can be found in [13], for type \mathbf{C}_n in [14] and for type \mathbf{G}_2 in [16]. Part (ii) is only proved for type \mathbf{A}_n and \mathbf{C}_n , but a simple calculation shows that part (ii) for type \mathbf{G}_2 remains true (for a proof see Proposition 7.1 in the Appendix).

Theorem. There exists a set $\mathbf{D} \subseteq \mathcal{P}(R^+)$ and suitable non-negative integers $M_{\mathbf{p}}(\lambda)$ attached to each element $\mathbf{p} \in \mathbf{D}$, such that the following holds:

- (i) The lattice points $S(\mathbf{D}, \lambda)$ parametrize a basis of $V(\lambda)$ and $\text{gr } V(\lambda)$ respectively. In particular,

$$\{X^{\mathbf{s}} v_\lambda \mid \mathbf{s} \in S(\mathbf{D}, \lambda)\}$$

forms a basis of $\text{gr } V(\lambda)$.

- (ii) We have

$$\mathbf{I}_\lambda = S(\mathfrak{n}^-)(\mathbf{U}(\mathfrak{n}^+) \circ \text{span}\{x_{-\beta}^{\lambda(\beta^\vee)+1} \mid \beta \in R^+\}).$$

We note that the order in the theorem above is important when treating the representation $V(\lambda)$, but we can choose for any $\mathbf{s} \in S(\mathbf{D}, \lambda)$ an arbitrary order of factors $x_{-\beta}$ in the product $X^{\mathbf{s}}$, such that the set

$$\{X^{\mathbf{s}} v_\lambda \mid \mathbf{s} \in S(\mathbf{D}, \lambda)\}$$

forms a basis of $V(\lambda)$.

Remark. The set \mathbf{D} and non-negative integers $M_{\mathbf{p}}(\lambda)$ are explicitly described in these papers.

Another interesting point is to understand the geometric aspects of the PBW filtration. In [9] degenerated flag varieties have been introduced which are certain varieties in the projectivization $\mathbb{P}(\text{gr } V(\lambda))$ of $\text{gr } V(\lambda)$. In type A_n (see [9, 10]) and type C_n (see [11]) it has been shown that the degenerated flag varieties can be embedded into a product of Grassmanians and desingularizations are constructed. Recently in [12] the notion of favourable modules has been introduced whose properties are governed by the combinatorics of an associated polytope and it has been shown that the corresponding degenerated flag varieties have nice properties, e.g. they are projectively normal and arithmetically Cohen-Macaulay varieties (see also Section 7). Especially it has been proved that $V(\lambda)$ for types A_n , C_n and G_2 are favourable (with respect to the polytope from Theorem 3.3), where the proof of this fact uses the Minkowski sum property of these polytopes. Our aim is to obtain similar results to Theorem 3.3 for type B_n for certain dominant integral weights and, motivated by the corresponding nice geometry of favourable modules, to construct various favourable modules.

4. DYCK PATH, POLYTOPES AND PBW BASES

The notion of Dyck paths is used in the papers [13, 14] in order to describe the set \mathbf{D} from Theorem 3.3 (and thus $S(\mathbf{D}, \lambda)$), but appears earlier in the literature in a different context. In this section we define two types of paths (type 1 and type 2), which we also call Dyck paths to avoid deviating from the established terminology. The set of Dyck paths of type 1 is similar to the definition given in [13, 14], while the type 2 Dyck paths are unions of type 1 Dyck paths with some extra conditions and are called double Dyck paths.

4.1. To each finite partially ordered set (S, \leq) we can associate a diagram, called the Hasse diagram. The vertices are given by the elements in S and we draw a line segment from x to y whenever y covers x , that is, whenever $x < y$ and there is no z such that $x < z < y$. We consider the partial order \leq on R^+ given by $\alpha \leq \beta \Leftrightarrow \beta - \alpha \in Q^+$. We shall be interested in the Hasse diagram of (R^+, \leq) and (R_i^+, \leq) . Note that the Hasse diagram of R_i^+ is obtained from the Hasse diagram of R^+ by erasing all vertices $\alpha \in R^+ \setminus R_i^+$.

Example. We find below the Hasse diagram of (R^+, \leq) for type A_n and B_n respectively. The vertices of the Hasse diagram for (R_3^+, \leq) of type B_n are marked by unfilled circles. Recall that the highest root is denoted by θ .

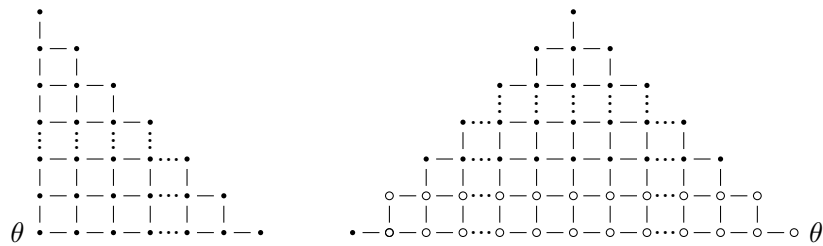

4.2. For the rest of this section we fix $i \in \{1, \dots, n\}$ and let $\lambda = m\omega_i$ for some $m \in \mathbb{Z}_+$. All roots of type B_n are of the form $\alpha_p + \dots + \alpha_q$ for some $1 \leq p \leq q \leq n$ or of the form $\alpha_p + \dots + \alpha_{2n-q} + 2\alpha_{2n-q+1} + \dots + 2\alpha_n$ for some $1 \leq p \leq 2n - q < n$. To keep the notation as simple as possible we define

$$\alpha_{p,q} := \begin{cases} \alpha_p + \dots + \alpha_q, & \text{if } 1 \leq p \leq q \leq n \\ \alpha_p + \dots + \alpha_{2n-q} + 2\alpha_{2n-q+1} + \dots + 2\alpha_n, & \text{if } 1 \leq p \leq 2n - q < n \end{cases}$$

Furthermore, we write $R_i^+(\ell)$ for $R_i^+ \setminus (R_i^+ \cap \{\alpha_{p,q} \mid q > \ell\})$. We call a subset of positive roots $\mathbf{p} = \{\beta(1), \dots, \beta(k)\}, k \geq 1$ a Dyck path of type 1 if and only if the following two conditions are

satisfied

- $\beta(1) = \alpha_{1,i}, \beta(k) = \alpha_{i,2n-i-1}$ or $\beta(1) = \alpha_{1,i+1}, \beta(k) = \alpha_{i,2n-i}$
 - if $\beta(s) = \alpha_{p,q}$, then $\beta(s+1) = \alpha_{p,q+1}$ or $\beta(s+1) = \alpha_{p+1,q}$.
- (4.1)

The set of all type 1 Dyck path is denoted by $\mathbf{D}^{\text{type } 1}$ and $\mathbf{D}_1^{\text{type } 1}$ (resp. $\mathbf{D}_2^{\text{type } 1}$) denotes the subset consisting of all type 1 Dyck paths starting at $\alpha_{1,i}$ (resp. $\alpha_{1,i+1}$). Furthermore, we call a subset of positive roots $\mathbf{p} = \{\beta(1), \dots, \beta(k)\}, k \geq 1$ a Dyck path of type 2 if and only if we can write $\mathbf{p} = \mathbf{p}_1 \cup \mathbf{p}_2$ ($\mathbf{p}_1 = \{\beta_1(1), \dots, \beta_1(k_1)\}, k_1 \geq 1, \mathbf{p}_2 = \{\beta_2(1), \dots, \beta_2(k_2)\}, k_2 \geq 1$) with the following properties:

- $\beta_1(1) = \alpha_{1,i}, \beta_2(1) = \alpha_{2,i}$ and $\beta_1(k_1) = \alpha_{j,2n-j}, \beta_2(k_2) = \alpha_{j+1,2n-j-1}$ for some $1 \leq j < i$
- \mathbf{p}_1 and \mathbf{p}_2 satisfy the second property of (4.1)
- $\mathbf{p}_1 \cap \mathbf{p}_2 = \emptyset$

The first property means that the last root in \mathbf{p}_2 is the upper right neighbour of the last root in \mathbf{p}_1 in the Hasse diagram of (R_i^+, \leq) . The set of all type 2 Dyck paths is denoted by $\mathbf{D}^{\text{type } 2}$. Summarizing, a type 1 Dyck path is a path in the sense of [13] in a specific area of the Hasse diagram of (R_i^+, \leq) and a type 2 Dyck path can be written as a disjoint union of two single type 1 Dyck paths. For this reason, we call the elements in $\mathbf{D}^{\text{type } 2}$ double Dyck paths.

Definition. We call a subset \mathbf{p} of positive roots a Dyck path if and only if $\mathbf{p} \in \mathbf{D} := \mathbf{D}^{\text{type } 1} \cup \mathbf{D}^{\text{type } 2}$.

Note that $\mathbf{D}^{\text{type } 1} = \emptyset$ if $i = n$ and $\mathbf{D}^{\text{type } 2} = \emptyset$ if $i = 1$ and $\mathbf{D}^{\text{type } 2} = \{R_2^+\}$ if $i = 2$. The interpretation of Dyck paths in the Hasse diagram is very helpful. The left figure (resp. right figure) shows the form of a type 1 (resp. type 2) Dyck path.

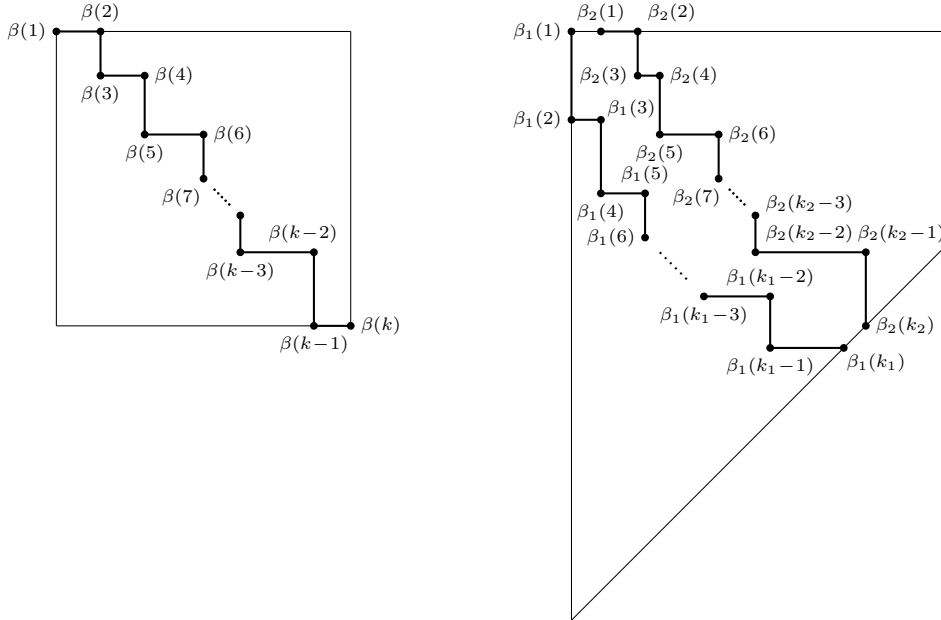

Example. We list all Dyck paths for $B_4, i = 3$. We have

$$\mathbf{D}^{\text{type } 1} = \left\{ \{ \alpha_{1,3}, \alpha_{2,3}, \alpha_{3,3}, \alpha_{3,4} \}, \{ \alpha_{1,3}, \alpha_{2,3}, \alpha_{2,4}, \alpha_{3,4} \}, \{ \alpha_{1,3}, \alpha_{1,4}, \alpha_{2,4}, \alpha_{3,4} \}, \{ \alpha_{1,4}, \alpha_{2,4}, \alpha_{3,4}, \alpha_{3,5} \}, \right. \\ \left. \{ \alpha_{1,4}, \alpha_{2,4}, \alpha_{2,5}, \alpha_{3,5} \}, \{ \alpha_{1,4}, \alpha_{1,5}, \alpha_{2,5}, \alpha_{3,5} \} \right\}.$$

$$\mathbf{D}^{\text{type}2} = \left\{ \begin{aligned} &\{\alpha_{1,3}, \alpha_{2,3}, \alpha_{1,4}, \alpha_{2,4}, \alpha_{1,5}, \alpha_{2,5}, \alpha_{1,6}, \alpha_{2,6}, \alpha_{1,7}\}, \{\alpha_{1,3}, \alpha_{2,3}, \alpha_{1,4}, \alpha_{2,4}, \alpha_{1,5}, \alpha_{2,5}, \alpha_{1,6}, \alpha_{2,6}, \alpha_{3,5}\}, \\ &\{\alpha_{1,3}, \alpha_{2,3}, \alpha_{1,4}, \alpha_{2,4}, \alpha_{1,5}, \alpha_{3,4}, \alpha_{1,6}, \alpha_{2,6}, \alpha_{3,5}\}, \{\alpha_{1,3}, \alpha_{2,3}, \alpha_{1,4}, \alpha_{3,3}, \alpha_{1,5}, \alpha_{3,4}, \alpha_{1,6}, \alpha_{2,6}, \alpha_{3,5}\}, \\ &\{\alpha_{1,3}, \alpha_{2,3}, \alpha_{1,4}, \alpha_{3,3}, \alpha_{1,5}, \alpha_{3,4}, \alpha_{2,5}, \alpha_{2,6}, \alpha_{3,5}\}, \{\alpha_{1,3}, \alpha_{2,3}, \alpha_{1,4}, \alpha_{2,4}, \alpha_{1,5}, \alpha_{3,4}, \alpha_{2,5}, \alpha_{2,6}, \alpha_{3,5}\}, \\ &\{\alpha_{1,3}, \alpha_{2,3}, \alpha_{1,4}, \alpha_{2,4}, \alpha_{3,3}, \alpha_{3,4}, \alpha_{2,5}, \alpha_{2,6}, \alpha_{3,5}\} \end{aligned} \right\}.$$

The corresponding polytope is defined by

$$P(\mathbf{D}, m\omega_i) = \left\{ \mathbf{s} = (s_\beta) \in \mathbb{R}_+^{|\mathbf{R}_i^+|} \mid \forall \mathbf{p} \in \mathbf{D} : \sum_{\beta \in \mathbf{p}} s_\beta \leq M_{\mathbf{p}}(m\omega_i) \right\}, \quad (4.2)$$

where we set

$$M_{\mathbf{p}}(m\omega_i) = \begin{cases} m & \text{if } \mathbf{p} \in \mathbf{D}^{\text{type}1} \\ m\omega_i(\theta^\vee) & \text{if } \mathbf{p} \in \mathbf{D}^{\text{type}2} \end{cases}$$

We consider the polytope $P(\mathbf{D}, m\omega_i)$ as a subset of $\mathbb{R}_+^{|\mathbf{R}_i^+|}$ by requiring $s_\beta = 0$ for $\beta \in \mathbf{R}^+ \setminus \mathbf{R}_i^+$.

Remark. Note that the set \mathbf{D} is a subset of $\mathcal{P}(\mathbf{R}_i^+)$ and depends therefore on i (unlike as in the \mathbf{A}_n , \mathbf{C}_n and \mathbf{G}_2 case). We do not expect that there exists a set $\mathbf{D}' \subset \mathcal{P}(\mathbf{R}^+)$ such that the following holds: for any dominant integral weight μ there exists non-negative integers $M_{\mathbf{p}}(\mu)$ ($\mathbf{p} \in \mathbf{D}'$) such that the integral points of the corresponding polytope (3.2) parametrize a basis of $\text{gr } V(\mu)$. We rather expect that there exists a polytope parametrizing a basis of the associated graded space where the coefficients of the describing inequalities might be greater than 1. We will demonstrate this in the \mathbf{B}_3 case (see Section 5).

4.3. For $\mathbf{s} \in S(\mathbf{D}, m\omega_i)$ let $\text{wt}(\mathbf{s}) := \sum_{\beta \in \mathbf{R}_i^+} s_\beta \beta$ and

$$S(\mathbf{D}, m\omega_i)^\mu = \{ \mathbf{s} \in S(\mathbf{D}, m\omega_i) \mid m\omega_i - \text{wt}(\mathbf{s}) = \mu \}.$$

We make the following conjecture and prove various cases in this paper. We set $\epsilon_i = 1$ if $i \leq 2$ and $\epsilon_i = 2$ else.

Conjecture. Let \mathfrak{g} be the Lie algebra of type \mathbf{B}_n and $1 \leq i \leq n$.

- (1) The lattice points $S(\mathbf{D}, m\omega_i)$ parametrize a basis of $V(m\omega_i)$ and $\text{gr } V(m\omega_i)$ respectively. In particular,

$$\{ X^{\mathbf{s}} v_{m\omega_i} \mid \mathbf{s} \in S(\mathbf{D}, m\omega_i) \}$$

forms a basis of $\text{gr } V(m\omega_i)$.

- (2) We have

$$\mathbf{I}_{m\omega_i} = S(\mathfrak{n}^-) \left(\mathbf{U}(\mathfrak{n}^+) \circ \text{span} \{ x_{-\theta}^{\omega_i(\theta^\vee)^{m+1}}, x_{-\alpha_{1,2n-i}}^{m+1}, x_{-\beta} \mid \beta \in \mathbf{R}^+ \setminus \mathbf{R}_i^+ \} \right).$$

- (3) The character and graded q -character respectively is given by

$$\begin{aligned} \text{ch } V(m\omega_i) &= \sum_{\mu \in \mathfrak{h}^*} |S(\mathbf{D}, m\omega_i)^\mu| e^\mu \\ \text{ch}_q \text{gr } V(m\omega_i) &= \sum_{\mathbf{s} \in S(\mathbf{D}, m\omega_i)} e^{m\omega_i - \text{wt}(\mathbf{s})} q^{\sum s_\beta}. \end{aligned}$$

- (4) We have an isomorphism of $S(\mathfrak{n}^-)$ -modules for all $\ell \in \mathbb{Z}_+$:

$$\text{gr } V((m + \epsilon_i \ell)\omega_i) \cong S(\mathfrak{n}^-)(v_{m\omega_i} \otimes v_{\epsilon_i \ell \omega_i}) \subseteq \text{gr } V(m\omega_i) \otimes \text{gr } V(\epsilon_i \ell \omega_i).$$

Lemma. The proof of Conjecture 4.3 can be reduced to the following three statements:

(i) The set

$$\{X^{\mathbf{s}} \mid \mathbf{s} \in S(\mathbf{D}, m\omega_i)\}$$

generates the module $S(\mathfrak{n}^-)/\mathbf{I}_{m\omega_i}$.

(ii) We have

$$S(\mathbf{D}, (m + \epsilon_i \ell)\omega_i) = S(\mathbf{D}, m\omega_i) + S(\mathbf{D}, \epsilon_i \ell \omega_i).$$

(iii) We have

$$\dim V(\ell\omega_i) = |S(\mathbf{D}, \ell\omega_i)| \text{ for } \ell \leq \epsilon_i.$$

Proof. Assume that part (1) of the conjecture holds. Part (3) of the conjecture follows immediately from part (1). Since $\mathbf{I}_{m\omega_i} v_{m\omega_i} = 0$, we have a surjective map

$$S(\mathfrak{n}^-)/\mathbf{I}_{m\omega_i} \longrightarrow \text{gr } V(m\omega_i)$$

and hence part (2) of the conjecture follows with part (1) and (i). It has been shown in [14, Proposition 3.7] (cf. also [12, Proposition 1.11]) that if $\{X^{\mathbf{s}} v_\lambda \mid \mathbf{s} \in S(\mathbf{D}, \lambda)\}$ is a basis of $\text{gr } V(\lambda)$ and $\{X^{\mathbf{s}} v_\mu \mid \mathbf{s} \in S(\mathbf{D}, \mu)\}$ is a basis of $\text{gr } V(\mu)$, then $\{X^{\mathbf{s}}(v_\lambda \otimes v_\mu), \mathbf{s} \in S(\mathbf{D}, \lambda) + S(\mathbf{D}, \mu)\}$ is a linearly independent subset of $\text{gr } V(\lambda) \otimes \text{gr } V(\mu)$ and therefore also a linearly independent subset of $V(\lambda) \otimes V(\mu)$. Since we have a surjective map

$$S(\mathfrak{n}^-)/\mathbf{I}_{(m+\epsilon_i \ell)\omega_i} \cong \text{gr } V((m + \epsilon_i \ell)\omega_i) \longrightarrow S(\mathfrak{n}^-)(v_{m\omega_i} \otimes v_{\epsilon_i \ell \omega_i}) \subseteq \text{gr } V(m\omega_i) \otimes \text{gr } V(\epsilon_i \ell \omega_i),$$

part (4) follows from part (1) and (ii). So it remains to prove that part (1) follows from (i)–(iii). If $m \leq \epsilon_i$ we are done with (iii), so let $m > \epsilon_i$. By induction we can suppose that $S(\mathbf{D}, (m - \epsilon_i)\omega_i)$ parametrizes a basis of $\text{gr } V((m - \epsilon_i)\omega_i)$ and by (i) and (iii) that $S(\mathbf{D}, \epsilon_i \omega_i)$ parametrizes a basis of $\text{gr } V(\epsilon_i \omega_i)$. Thus, together with (ii), we obtain similar as above that $\{X^{\mathbf{s}}(v_{(m-\epsilon_i)\omega_i} \otimes v_{\epsilon_i \omega_i}), \mathbf{s} \in S(\mathbf{D}, m\omega_i)\}$ is a linearly independent subset of $V((m - \epsilon_i)\omega_i) \otimes V(\epsilon_i \omega_i)$. Since $V(m\omega_i) \cong \mathbf{U}(\mathfrak{n}^-)(v_{(m-\epsilon_i)\omega_i} \otimes v_{\epsilon_i \omega_i})$ and $\dim V(m\omega_i) = \dim \text{gr } V(m\omega_i)$ part (1) follows. \square

Therefore it will be enough to prove the above lemma. The first part of the lemma is proved in full generality in Section 4.4 whereas the second part is proved only for several special cases ($1 \leq i \leq 3$ and n arbitrary or i arbitrary and $1 \leq n \leq 4$) in Section 4.5. The proof of the third part for these special cases is an easy calculation and will be omitted.

4.4. Proof of Lemma 4.3 (i). We choose a total order \prec on R^+ :

$$\alpha_{p,q} \prec \alpha_{s,t} : \Leftrightarrow q < t \text{ or } q = t \text{ and } p > s.$$

Interpreted in the Hasse diagram this means that we order the roots from the bottom to the top and from left to right. We extend this order to the induced homogeneous reverse lexicographic order on the monomials in $S(\mathfrak{n}^-)$. We order the set of positive roots $R^+ = \{\beta_1, \dots, \beta_N\}$ with respect to \prec :

$$\beta_N \prec \beta_{N-1} \prec \dots \prec \beta_1.$$

The definition of the order \prec implies the following. Let $\beta_\ell \prec \beta_p$ and $\nu \in R^+$, such that $\beta_\ell - \nu \in R^+$ and $\beta_p - \nu \in R^+$, then

$$\beta_\ell - \nu \prec \beta_p - \nu.$$

We define differential operators for $\alpha \in R^+$ on $S(\mathfrak{n}^-)$ by:

$$\partial_\alpha x_{-\beta} := \begin{cases} x_{-\beta+\alpha}, & \text{if } \beta - \alpha \in R^+ \\ 0, & \text{else.} \end{cases}$$

The operators satisfy

$$\partial_\alpha x_{-\beta} = c_{\alpha,\beta} [x_\alpha, x_{-\beta}],$$

where $c_{\alpha,\beta} \in \mathbb{C}$ are some non-zero constants.

Lemma. Let $\sum_{\mathbf{r} \in \mathbb{Z}_+^N} c_{\mathbf{r}} X^{\mathbf{r}} \in S(\mathfrak{n}^-)$ and $\nu \in R^+$. We set

$$\mathbf{t} = \max \{ \mathbf{r} \mid \partial_{\nu} X^{\mathbf{r}} \neq 0, c_{\mathbf{r}} \neq 0 \}.$$

Then the maximal monomial in $\sum_{\mathbf{r} \in \mathbb{Z}_+^N} c_{\mathbf{r}} \partial_{\nu} X^{\mathbf{r}}$ is a summand of $\partial_{\nu} X^{\mathbf{t}}$.

Proof. We express $\partial_{\nu} X^{\mathbf{t}}$ as a sum of monomials and let $X^{\bar{\mathbf{t}}}$ be the maximal element appearing in this expression. From the definition of the differential operators it is clear that

$$\bar{t}_{\beta_{\ell}} = \begin{cases} t_{\beta_{\ell}}, & \text{if } \ell \neq j_{\mathbf{t}}, \beta_{\ell} \neq \beta_{j_{\mathbf{t}}} - \nu \\ t_{\beta_{\ell}} - 1, & \text{if } \ell = j_{\mathbf{t}} \\ t_{\beta_{\ell}} + 1, & \text{if } \beta_{\ell} = \beta_{j_{\mathbf{t}}} - \nu \end{cases}, \quad \text{where } \beta_{j_{\mathbf{t}}} = \max_{1 \leq k \leq N} \{ \beta_k \mid \partial_{\nu} x_{-\beta_k} \neq 0, t_{\beta_k} \neq 0 \}.$$

With other words, $X^{\bar{\mathbf{t}}}$ is a scalar multiple of

$$\prod_{\ell \neq j_{\mathbf{t}}} x_{-\beta_{\ell}}^{t_{\beta_{\ell}}} x_{-\beta_{j_{\mathbf{t}}}}^{t_{\beta_{j_{\mathbf{t}}}} - 1} x_{-\beta_{j_{\mathbf{t}}} + \nu}.$$

Moreover, let $X^{\bar{\mathbf{r}}}$ be any monomial with $c_{\mathbf{r}} \neq 0$ and $\partial_{\nu} X^{\mathbf{r}} \neq 0$. Similar as above we denote by $X^{\bar{\mathbf{r}}}$ the maximal element which appears as a summand of $\partial_{\nu} X^{\mathbf{r}}$. In the rest of the proof we shall verify that $\bar{\mathbf{t}} \succ \bar{\mathbf{r}}$. Since $\mathbf{t} \succ \mathbf{r}$ this follows immediately if $j_{\mathbf{t}} \leq j_{\mathbf{r}}$. So suppose that $j_{\mathbf{t}} > j_{\mathbf{r}}$ and $\bar{\mathbf{t}} \prec \bar{\mathbf{r}}$. This is only possible if $r_{\beta_{j_{\mathbf{r}}}} - 1 < t_{\beta_{j_{\mathbf{r}}}}$ and $t_{\beta_p} = r_{\beta_p}$ for $1 \leq p < j_{\mathbf{r}}$. Therefore we can deduce from $\mathbf{t} \succ \mathbf{r}$ that $r_{\beta_{j_{\mathbf{r}}}} = t_{\beta_{j_{\mathbf{r}}}}$. It follows $t_{\beta_{j_{\mathbf{r}}}} \neq 0$, $\partial_{\nu} x_{-\beta_{j_{\mathbf{r}}}} \neq 0$ and $\beta_{j_{\mathbf{t}}} \prec \beta_{j_{\mathbf{r}}}$, which is a contradiction to the choice of $\beta_{j_{\mathbf{t}}}$. \square

The proof of Lemma 4.3 (i) proceeds as follows. We use the above monomial order on $S(\mathfrak{n}^-)$ and prove that any monomial $X^{\mathbf{s}}$, $\mathbf{s} \notin S(\mathbf{D}, m\omega_i)$ in $S(\mathfrak{n}^-)/\mathbf{I}_{m\omega_i}$ can be written as a sum of monomials, where each monomial appearing in this expression is less than $X^{\mathbf{s}}$. We repeat this argument for any summand $X^{\mathbf{t}}$, $\mathbf{t} \notin S(\mathbf{D}, m\omega_i)$ in this expression. After finitely many steps $X^{\mathbf{s}}$ can be written as a sum of monomials $X^{\mathbf{t}}$, $\mathbf{t} \in S(\mathbf{D}, m\omega_i)$ which is exactly the statement of the lemma. So let $X^{\mathbf{s}}$, $\mathbf{s} \notin S(\mathbf{D}, m\omega_i)$ be a monomial in $S(\mathfrak{n}^-)/\mathbf{I}_{m\omega_i}$. Then there exists a Dyck path \mathbf{p} such that $\sum_{\beta} s_{\beta} > M_{\mathbf{p}}(m\omega_i)$. We define another multi-exponent $\mathbf{r} = (r_{\beta})$ by $r_{\beta} = s_{\beta}$ if $\beta \in \mathbf{p}$ and $r_{\beta} = 0$ otherwise. Since we have a monomial order it will be enough to prove that $X^{\mathbf{r}}$ can be written as a sum of smaller monomials. Hence the following proposition proves Lemma 4.3 (i).

Proposition. Let $\mathbf{p} \in \mathbf{D}$ and $\mathbf{s} \in \mathbb{Z}_+^{|\mathbf{R}_i^+|}$ be a multi-exponent supported on \mathbf{p} , i.e. $s_{\beta} = 0$ for $\beta \notin \mathbf{p}$. Suppose $\sum_{\beta \in \mathbf{p}} s_{\beta} > M_{\mathbf{p}}(m\omega_i)$. Then there exists constants $c_{\mathbf{t}} \in \mathbb{C}$, $\mathbf{t} \in \mathbb{Z}_+^{|\mathbf{R}_i^+|}$ such that

$$X^{\mathbf{s}} + \sum_{\mathbf{t} \prec \mathbf{s}} c_{\mathbf{t}} X^{\mathbf{t}} \in \mathbf{I}_{\lambda}.$$

Proof. First we assume that $\mathbf{p} = \{\beta(1), \dots, \beta(k)\} \in \mathbf{D}_2^{\text{type 1}}$. Note that the ideal \mathbf{I}_{λ} is stable under the action of the differential operators and $x_{-\alpha_{1, 2n-i}}^{s_{\beta(1)} + \dots + s_{\beta(k)}} \in \mathbf{I}_{\lambda}$. In the following we write simply $x_{p,q} := x_{-\alpha_{p,q}}$ and $s_{p,q} := s_{\alpha_{p,q}}$ and rewrite the monomial $x_{-\beta(1)} \cdots x_{-\beta(k)}$ as follows. We can choose a sequence of integers

$$1 = p_0 \leq p_1 < p_2 < \cdots < p_{r-1} < p_r = i < i+1 = q_0 < q_1 < q_2 < \cdots < q_{r-1} \leq q_r = 2n - i$$

with $1 \leq p_{\ell} \leq q_{\ell} \leq n$ or $1 \leq p_{\ell} \leq 2n - q_{\ell} < n$ for all $0 \leq \ell \leq r$ such that

$$x_{-\beta(1)} \cdots x_{-\beta(k)} = x_{1, i+1} \cdots x_{p_1, i+1} x_{p_1, i+2} \cdots x_{p_1, q_1} x_{p_1+1, q_1} \cdots x_{p_2, q_1} x_{p_2, q_1+1} \cdots x_{p_2, q_2} \cdots x_{p_r, q_r}.$$

See the picture below for a better imagination:

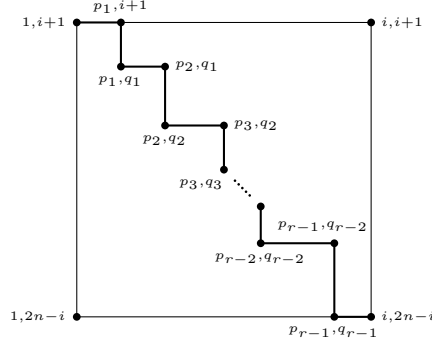

For $0 \leq \ell \leq r$ we define $s_{p_\ell} := s_{p_\ell, q_{\ell-1}+1} + \cdots + s_{p_\ell, q_\ell} + s_{p_\ell+1, q_\ell} + \cdots + s_{p_\ell+1, q_\ell}$ and $|\mathbf{s}| := s_{\beta(1)} + \cdots + s_{\beta(k)}$. Then

$$\partial_{\alpha_{1, p_1-1}}^{s_{p_1}} x_{1, 2n-i}^{|\mathbf{s}|} = x_{1, 2n-i}^{|\mathbf{s}| - s_{p_1}} x_{p_1, 2n-i}^{s_{p_1}} \in \mathbf{I}_\lambda.$$

Since $\partial_{\alpha_{1, t}} x_{t, 2n-i} = 0$ for $1 < t \leq l < i$ we conclude with $p_1 < p_2 < \cdots < p_r$:

$$\partial_{\alpha_{1, p_r-1}}^{s_{p_r}} \cdots \partial_{\alpha_{1, p_2-1}}^{s_{p_2}} \partial_{\alpha_{1, p_1-1}}^{s_{p_1}} x_{1, 2n-i}^{|\mathbf{s}|} = x_{1, 2n-i}^{|\mathbf{s}| - \sum_{t=1}^r s_{p_t}} x_{p_1, 2n-i}^{s_{p_1}} x_{p_2, 2n-i}^{s_{p_2}} \cdots x_{p_r, 2n-i}^{s_{p_r}} \in \mathbf{I}_\lambda.$$

Note that the operator $\partial_{\alpha_{i+1, 2n-(i+1)}}$ acts non-trivially on each $x_{p_j, 2n-i}$. The choice of the order implies that the largest monomial in

$$\partial_{\alpha_{i+1, 2n-(i+1)}}^{s_{1, i+1} + \cdots + s_{p_1, i+1}} x_{1, 2n-i}^{|\mathbf{s}| - \sum_{t=1}^r s_{p_t}} x_{p_1, 2n-i}^{s_{p_1}} x_{p_2, 2n-i}^{s_{p_2}} \cdots x_{p_r, 2n-i}^{s_{p_r}} \quad (4.3)$$

is obtained by acting with $\partial_{\alpha_{i+1, 2n-(i+1)}}$ only on the the largest element $x_{1, 2n-i}$. So the largest monomial in (4.3) with respect to \prec is

$$x_{1, i+1}^{s_{1, i+1} + \cdots + s_{p_1, i+1}} x_{p_1, 2n-i}^{s_{p_1}} x_{p_2, 2n-i}^{s_{p_2}} \cdots x_{p_r, 2n-i}^{s_{p_r}}. \quad (4.4)$$

Each of the operators $\partial_{\alpha_{p_1-1, p_1-1}}, \dots, \partial_{\alpha_{2, 2}}, \partial_{\alpha_{1, 1}}$ act trivially on each $x_{p_j, 2n-i}$. Since

$$\partial_{\alpha_{p_1-1, p_1-1}}^{s_{p_1, i+1}} \cdots \partial_{\alpha_{2, 2}}^{s_{3, i+1} + \cdots + s_{p_1, i+1}} \partial_{\alpha_{1, 1}}^{s_{2, i+1} + \cdots + s_{p_1, i+1}} x_{1, i+1}^{s_{1, i+1} + \cdots + s_{p_1, i+1}} = x_{1, i+1}^{s_{1, i+1}} \cdots x_{p_1, i+1}^{s_{p_1, i+1}}$$

we obtain by acting with these operators on (4.4) that

$$x_{1, i+1}^{s_{1, i+1}} \cdots x_{p_1, i+1}^{s_{p_1, i+1}} x_{p_1, 2n-i}^{s_{p_1}} x_{p_2, 2n-i}^{s_{p_2}} \cdots x_{p_r, 2n-i}^{s_{p_r}} + \sum \text{smaller monomials} \in \mathbf{I}_\lambda. \quad (4.5)$$

In the next step we act with the operators $\partial_{\alpha_{i+1, 2n-q_1}}, \partial_{\alpha_{i+1, 2n-q_1+1}}, \dots, \partial_{\alpha_{i+1, 2n-(q_0+1)}}$ on $x_{p_1, 2n-i}$ and obtain with Lemma 4.4:

$$\begin{aligned} \partial_{\alpha_{i+1, 2n-q_1}}^{s_{p_1} - (s_{p_1, q_1-1} + \cdots + s_{p_1, q_0+1})} \partial_{\alpha_{i+1, 2n-q_1+1}}^{s_{p_1, q_1-1}} \cdots \partial_{\alpha_{i+1, 2n-(q_0+1)}}^{s_{p_1, q_0+1}} x_{p_1, 2n-i}^{s_{p_1}} \\ = x_{p_1, q_1}^{s_{p_1} - (s_{p_1, q_1-1} + \cdots + s_{p_1, q_0+1})} x_{p_1, q_1-1}^{s_{p_1, q_1-1}} \cdots x_{p_1, q_0+1}^{s_{p_1, q_0+1}} + \sum \text{smaller monomials} \end{aligned} \quad (4.6)$$

Since $x_{p_1, 2n-i}$ is the maximal element with respect to \prec among the factors in the leading term of (4.5) we get by combining Lemma 4.4 and (4.6)

$$x_{1, i+1}^{s_{1, i+1}} \cdots x_{p_1, i+1}^{s_{p_1, i+1}} x_{p_1, q_1}^{\sum_{\ell=p_1}^{p_2} s_{\ell, q_1}} x_{p_1, q_1-1}^{s_{p_1, q_1-1}} \cdots x_{p_1, q_0+1}^{s_{p_1, q_0+1}} x_{p_2, 2n-i}^{s_{p_2}} \cdots x_{p_r, 2n-i}^{s_{p_r}} + \sum \text{smaller monomials} \in \mathbf{I}_\lambda. \quad (4.7)$$

Now we act with the operators $\partial_{\alpha_{p_2-1, p_2-1}}, \dots, \partial_{\alpha_{p_1+1, p_1+1}}, \partial_{\alpha_{p_1, p_1}}$:

$$\begin{aligned} \partial_{\alpha_{p_2-1, p_2-1}}^{s_{p_2, q_1}} \cdots \partial_{\alpha_{p_1+1, p_1+1}}^{s_{p_1+2, q_1} + \cdots + s_{p_2, q_1}} \partial_{\alpha_{p_1, p_1}}^{s_{p_1+1, q_1} + s_{p_1+2, q_1} + \cdots + s_{p_2, q_1}} x_{p_1, q_1}^{s_{p_1, q_1} + s_{p_1+1, q_1} + \cdots + s_{p_2, q_1}} = \\ x_{p_1, q_1}^{s_{p_1, q_1}} x_{p_1+1, q_1}^{s_{p_1+1, q_1}} \cdots x_{p_2, q_1}^{s_{p_2, q_1}}. \end{aligned} \quad (4.8)$$

Since $\partial_{\alpha_{p_2-1, p_2-1}}, \dots, \partial_{\alpha_{p_1+1, p_1+1}}, \partial_{\alpha_{p_1, p_1}}$ act trivially on each $x_{p_j, 2n-1}$ and x_{p_1, q_1} is the largest element with respect to \prec among the remaining factors in the leading term of (4.7) we get by combining (4.7) and (4.8) that the following element is the sum of strictly smaller monomials in $S(\mathfrak{n}^-)/\mathbf{I}_\lambda$:

$$x_{1, i+1}^{s_{1, i+1}} \cdots x_{p_1, i+1}^{s_{p_1, i+1}} x_{p_1, q_1}^{s_{p_1, q_1}} x_{p_1, q_1-1}^{s_{p_1, q_1-1}} x_{p_1, q_1-2}^{s_{p_1, q_1-2}} \cdots x_{p_1, q_0+1}^{s_{p_1, q_0+1}} x_{p_1+1, q_1}^{s_{p_1+1, q_1}} \cdots x_{p_2, q_1}^{s_{p_2, q_1}} x_{p_2, 2n-i}^{s_{p_2, 2n-i}} \cdots x_{p_r, 2n-i}^{s_{p_r, 2n-i}}$$

If we repeat the above steps with $x_{p_2, 2n-i}^{s_{p_2, 2n-i}} \cdots x_{p_r, 2n-i}^{s_{p_r, 2n-i}}$ we can deduce the proposition for $\mathbf{p} \in \mathbf{D}_2^{\text{type 1}}$.

Now suppose that $\mathbf{p} \in \mathbf{D}_1^{\text{type 1}}$ is of the form

$$\mathbf{p} = \{\alpha_{1, i}, \alpha_{2, i} \cdots \alpha_{\ell, i}, \alpha_{\ell, i+1}, \dots, \alpha_{r, i+1}, \alpha_{r, i+2}, \dots, \alpha_{i, 2n-i-1}\}.$$

We shall construct another Dyck path as follows. We set $\mathbf{q} = \{\alpha_{\ell, i+1}, \dots, \alpha_{r, i+1}, \alpha_{r, i+2}, \dots, \alpha_{i, 2n-i-1}\}$.

Then it is easy to see that we can find an element $\tilde{\mathbf{q}} \in \mathcal{P}(R_i^+)$ such that the path $\bar{\mathbf{q}} := \mathbf{q} \cup \tilde{\mathbf{q}} \in \mathbf{D}_2^{\text{type 1}}$.

We define a multi-exponent $s(\bar{\mathbf{q}})$ by

$$s(\bar{\mathbf{q}})_\beta = s_\beta, \text{ if } \beta \in \mathbf{q}, \quad s(\bar{\mathbf{q}})_{\alpha_{1, i+1}} = s_{\alpha_{1, i}} + \cdots + s_{\alpha_{\ell, i}}, \quad \text{and else } s(\bar{\mathbf{q}})_\beta = 0.$$

By our previous calculations we get

$$X^{s(\bar{\mathbf{q}})} + \sum_{\mathbf{t} \prec s(\bar{\mathbf{q}})} c_{\mathbf{t}} X^{\mathbf{t}} \in \mathbf{I}_\lambda. \quad (4.9)$$

Note that each operator $\partial_{\alpha_{1, 1}}, \dots, \partial_{\alpha_{\ell-1, \ell-1}}$ acts trivially on x_β for all $\beta \in \mathbf{q}$ and $\partial_{\alpha_{i+1, i+1}}$ acts trivially on x_β for all $\beta \in \mathbf{q} \setminus \{\alpha_{\ell+1, i+1}, \dots, \alpha_{r, i+1}\}$. Since $x_{1, i+1} \succ x_{j, i+1}$ for all $\ell+1 \leq j \leq r$ the maximal element when acting with $\partial_{\alpha_{i+1, i+1}}$ on (4.9) is obtained by acting with $\partial_{\alpha_{i+1, i+1}}$ on $x_{1, i+1}$.

We have

$$\partial_{\alpha_{i+1, i+1}}^{s_{1, i+1} + \cdots + s_{\ell, i}} X^{s(\bar{\mathbf{q}})} + = x_{1, i}^{s_{1, i} + \cdots + s_{\ell, i}} X^{s(\mathbf{q})} + \sum \text{smaller monomials} \in \mathbf{I}_\lambda, \quad (4.10)$$

where $s(\mathbf{q})$ is the multi-exponent defined by $s(\mathbf{q})_\beta = s_\beta$ if $\beta \in \mathbf{q}$ and $s(\mathbf{q})_\beta = 0$ otherwise. In the last step we act with $\partial_{\alpha_{\ell-1, \ell-1}}^{s_{\ell-1, i} + \cdots + s_{\ell, i}} \cdots \partial_{\alpha_{1, 1}}^{s_{1, i} + \cdots + s_{\ell, i}}$ on (4.10) and get

$$X^{\mathbf{s}} + \sum_{\mathbf{t} \prec \mathbf{s}} c_{\mathbf{t}} X^{\mathbf{t}} \in \mathbf{I}_\lambda.$$

Now we assume that $\mathbf{p} \in \mathbf{D}^{\text{type 2}}$, which means that \mathbf{p} can be written as a union $\mathbf{p} = \mathbf{p}_1 \cup \mathbf{p}_2$ with $\mathbf{p}_1 = \{\beta_1(1), \dots, \beta_1(k_1)\}$ and $\mathbf{p}_2 = \{\beta_2(1), \dots, \beta_2(k_2)\}$ such that $\beta_1(k_1) = \alpha_{j-1, 2n-j+1}$ and $\beta_2(k_2) = \alpha_{j, 2n-j}$. We have

$$x_{1, 2n-1}^{s_{\beta_1(1)} + \cdots + s_{\beta_1(k_1)} + s_{\beta_2(1)} + \cdots + s_{\beta_2(k_2)}} \in \mathbf{I}_\lambda. \quad (4.11)$$

We will prove the statement of the proposition by upward induction on $j \in \{2, \dots, i\}$. If $j = 2$, we have

$$\mathbf{p}_1 = \{\alpha_{1, i}, \alpha_{1, i+1}, \dots, \alpha_{1, 2n-1}\} \text{ and } \mathbf{p}_2 = \{\alpha_{2, i}, \alpha_{2, i+1}, \dots, \alpha_{2, 2n-2}\}$$

and therefore by acting on (4.11) we get

$$\begin{aligned} \partial_{\alpha_{1, 2n-i}}^{s_{2, i}} \cdots \partial_{\alpha_{1, 3}}^{s_{2, 2n-3}} \partial_{\alpha_{1, 2}}^{s_{2, 2n-2}} \partial_{\alpha_{2, 2n-i}}^{s_{1, i}} \cdots \partial_{\alpha_{2, 3}}^{s_{1, 2n-2}} \partial_{\alpha_{2, 2}}^{s_{1, 2n-2}} x_{1, 2n-1}^{s_{\beta_1(1)} + \cdots + s_{\beta_1(k_1)} + s_{\beta_2(1)} + \cdots + s_{\beta_2(k_2)}} = \\ = x_{1, 2n-1}^{s_{1, 2n-1}} \cdots x_{1, i+1}^{s_{1, i+1}} x_{1, i}^{s_{1, i}} x_{2, 2n-2}^{s_{2, 2n-2}} \cdots x_{2, i+1}^{s_{2, i+1}} x_{2, i}^{s_{2, i}} + \sum \text{smaller monomials} \in \mathbf{I}_\lambda \end{aligned}$$

and the induction begins. As before we rewrite the Dyck path as follows:

$$x_{-\beta_1(1)} x_{-\beta_1(2)} \cdots x_{-\beta_1(k_1)} = x_{1, i} x_{1, i+1} \cdots x_{b_1, c_1} x_{b_1+1, c_1} \cdots x_{b_2, c_1} x_{b_2, c_1+1} \cdots x_{b_2, c_2} \cdots x_{b_r, c_r}$$

$$x_{-\beta_2(1)} x_{-\beta_2(2)} \cdots x_{-\beta_2(k_2)} = x_{2, i} x_{3, i} \cdots x_{p_1, i} x_{p_1, i+1} \cdots x_{p_1, q_1} x_{p_1+1, q_1} \cdots x_{p_2, q_1} x_{p_2, q_1+1} \cdots x_{p_2, q_2} \cdots x_{p_t, q_t}$$

where

$$1 = b_0 = b_1 < b_2 < \cdots < b_{r-1} \leq b_r = j - 1, \quad i = c_0 < c_1 < c_2 < \cdots < c_{r-1} \leq c_r = 2n - j + 1,$$

$$2 = p_0 \leq p_1 < p_2 < \cdots < p_{r-1} \leq p_t = j \text{ and } i = q_0 < q_1 < q_2 < \cdots < q_{t-1} \leq q_t = 2n - j.$$

For a pictorial illustration see the picture below:

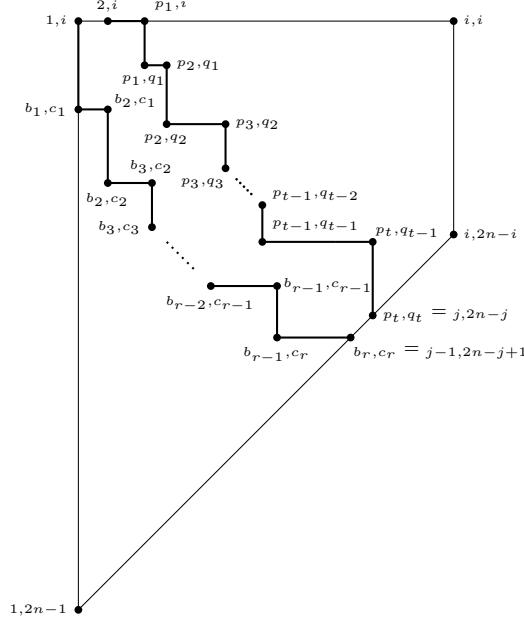

We will construct another path $\bar{\mathbf{p}} \in \mathbf{D}^{\text{type } 2}$. We set

$$\tilde{\mathbf{p}}_1 = \mathbf{p} \setminus \{\alpha_{p_t, q_{t-1}}, \alpha_{p_t, q_{t-1}+1}, \dots, \alpha_{p_t, q_t}\}.$$

Then it is easy to see that there exists a unique element $\tilde{\mathbf{p}}_2 \in \mathcal{P}(R_i^+)$ such that $\bar{\mathbf{p}} = \tilde{\mathbf{p}}_1 \cup \tilde{\mathbf{p}}_2 \in \mathbf{D}^{\text{type } 2}$ and the roots $\alpha_{j-2, 2n-j+2}$, $\alpha_{j-1, 2n-j+1}$ appear in $\bar{\mathbf{p}}$. We define a multi-exponent $s(\bar{\mathbf{p}})$ by

$$s(\bar{\mathbf{p}})_\beta = s_\beta, \quad \text{if } \beta \in \tilde{\mathbf{p}}_1 \setminus \{\alpha_{b_{r-1}, c_r}\}, \quad s(\bar{\mathbf{p}})_{\alpha_{b_{r-1}, c_r}} = s_{b_{r-1}, c_r} + s_{p_t, q_{t-1}} + s_{p_t, q_{t-1}+1} + \dots + s_{p_t, q_t}$$

and $s(\bar{\mathbf{p}})_\beta = 0$ otherwise. The induction hypothesis yields

$$X^{s(\bar{\mathbf{p}})} + \sum_{\mathbf{t} \prec s(\bar{\mathbf{p}})} c_{\mathbf{t}} X^{\mathbf{t}} \in \mathbf{I}_\lambda. \quad (4.12)$$

Now we want to act with suitable operators on (4.12) such that the leading term is the required monomial $X^{\mathbf{s}}$. Since x_{b_{r-1}, c_r} is the maximal element in $X^{s(\bar{\mathbf{p}})}$ and $\partial_{\alpha_{b_{r-1}, j}}, \dots, \partial_{\alpha_{b_{r-1}, 2n-q_{t-1}}}$ act non trivially on x_{b_{r-1}, c_r} we obtain the desired property

$$\begin{aligned} \partial_{\alpha_{b_{r-1}, 2n-q_{t-1}}}^{s_{p_t, q_{t-1}}} \dots \partial_{\alpha_{b_{r-1}, j}}^{s_{p_t, q_t}} X^{s(\bar{\mathbf{p}})} + \sum_{\mathbf{t} \prec s(\bar{\mathbf{p}})} c_{\mathbf{t}} \partial_{\alpha_{b_{r-1}, 2n-q_{t-1}}}^{s_{p_t, q_{t-1}}} \dots \partial_{\alpha_{b_{r-1}, j}}^{s_{p_t, q_t}} X^{\mathbf{t}} = \\ = X^{\mathbf{s}} + \sum \text{smaller monomials} \in \mathbf{I}_\lambda. \end{aligned}$$

□

4.5. Proof of Lemma 4.3 (ii) in various cases. In this section we shall prove various cases of Lemma 4.3 (ii). Consider the partial order

$$\alpha_{j, k} \leq \alpha_{p, r} \Leftrightarrow (j \geq p \wedge k \geq r)$$

and suppose we are given a multi-exponent $\mathbf{s} \in S(\mathbf{D}, m\omega_i)$. Let $\mathbf{R}^{\mathbf{s}} = \{\beta \in R_i^+(2n-i) \mid s_\beta \neq 0\}$ and $\mathbf{T}^{\mathbf{s}}$ the set of minimal elements in $\mathbf{R}^{\mathbf{s}}$ with respect to \leq . We define a multi-exponent $\mathbf{t}^{\mathbf{s}}$ by

$t_\beta = 1$, if $\beta \in T^s$ and $t_\beta = 0$ otherwise and call it the multi-exponent associated to \mathbf{s} . The following lemma can be deduced from [13, Proposition 3.7].

Lemma. Let $\mathbf{s} \in S(\mathbf{D}, m\omega_i)$ such that $s_\beta \neq 0$ implies $\beta \in R_i^+(2n - i - 1)$ (resp. $\beta \in (R_i^+ \cap R_{i+1}^+)(2n - i)$). Then we have

$$\mathbf{s} - \mathbf{t}^s \in S(\mathbf{D}, (m - 1)\omega_i).$$

For a multi-exponent $\mathbf{t} \in \mathbb{Z}_+^{|R_i^+|}$ define

$$\text{supp}(\mathbf{t}) = \{\beta \in R_i^+ \mid t_\beta \neq 0\},$$

and let

$$\mathbf{T}(1) = \{\mathbf{t} \in \mathbb{Z}_+^{|R_i^+|} \mid t_\beta \leq 1, \forall \beta \in R_i^+\}.$$

The following proposition proves Lemma 4.3 (ii) for $1 \leq i \leq 3$, where the proof for $i = 3$ is very technical and is given in the appendix (see Section 7.2).

Proposition. Let $1 \leq i \leq 3$ and $m \geq \epsilon_i$. Then we have

$$S(\mathbf{D}, m\omega_i) = S(\mathbf{D}, (m - \epsilon_i)\omega_i) + S(\mathbf{D}, \epsilon_i\omega_i).$$

Proof. The proof for $i = 1$ is straightforward since $S(\mathbf{D}, m\omega_1)$ is determined by two inequalities. *Proof for $i = 2$:* Suppose $\mathbf{s} \in S(\mathbf{D}, m\omega_2)$ and recall that $\mathbf{D}^{\text{type } 2} = \{R_2^+\}$. We will construct a multi-exponent $\mathbf{t} \in S(\mathbf{D}, \omega_2)$ such that $\mathbf{s} - \mathbf{t} \in S(\mathbf{D}, (m - 1)\omega_2)$. We prove the statement by induction on s_θ and start with $s_\theta = 0$. In this case we note that $\sum_{\beta \in \mathbf{p}} (s_\beta - t_\beta) \leq m - 1$ for all $\mathbf{p} \in \mathbf{D}^{\text{type } 1}$ implies already $\mathbf{s} - \mathbf{t} \in S(\mathbf{D}, (m - 1)\omega_2)$. The proof proceeds by several case considerations. For the readers convenience we illustrate each case by means of the Hasse diagram. We make the following convention: a bold dot (resp. square) in the Hasse diagram indicates that the corresponding entry of \mathbf{s} is zero (resp. non-zero).

Case 1: In this case we suppose $s_{2,2n-2} \neq 0$.



If $s_{1,2} = s_{2,2} = 0$ the statement follows from Lemma 4.5. So let $\mathbf{t} \in \mathbf{T}(1)$ be the multi-exponent with $\text{supp}(\mathbf{t}) = \{\alpha_{2,2n-2}, \alpha_{k,2}\}$, where $k = \min\{1 \leq j \leq 2 \mid s_{j,2} \neq 0\}$. It is easy to see that $\mathbf{t} \in S(\mathbf{D}, \omega_2)$ and $\mathbf{s} - \mathbf{t} \in S(\mathbf{D}, (m - 1)\omega_2)$.

Case 2: In this case we suppose that $s_{2,2n-2} = 0$ and $s_{1,2} \neq 0$.

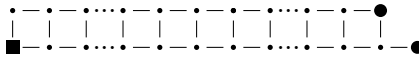

If $s_{1,2n-2} = 0$ the statement follows as above from Lemma 4.5. So let $\mathbf{t} \in \mathbf{T}(1)$ be the multi-exponent with $\text{supp}(\mathbf{t}) = \{\alpha_{1,2}, \alpha_{1,2n-2}\}$. It is straightforward to prove that $\mathbf{t} \in S(\mathbf{D}, \omega_2)$ and $\mathbf{s} - \mathbf{t} \in S(\mathbf{D}, (m - 1)\omega_2)$.

Case 3: In this case we suppose $s_{1,2} = s_{2,2n-2} = 0$. Again with Lemma 4.5 we can assume that $s_{2,2} \neq 0$ and $s_{1,2n-2} \neq 0$.

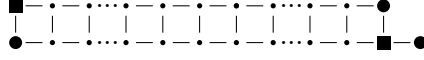

Let $\mathbf{t} \in \mathbf{T}(1)$ be the multi-exponent with $\text{supp}(\mathbf{t}) = \{\alpha_{2,2}, \alpha_{1,k}\}$, where $k = \min\{3 \leq j \leq 2n - 2 \mid s_{1,j} \neq 0\}$ (see the unfilled squares below).

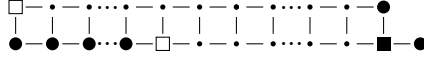

It follows $\mathbf{t} \in S(\mathbf{D}, \omega_2)$. Suppose we are given a Dyck path $\mathbf{p} \in \mathbf{D}_1^{\text{type}1}$ with $\sum_{\beta \in \mathbf{p}} (s_\beta - t_\beta) = m$, which is only possible if $t_\beta = 0$ for all $\beta \in \mathbf{p}$. It follows that \mathbf{p} is of the form

$$\mathbf{p} = \{\alpha_{1,2}, \dots, \alpha_{1,p}, \alpha_{2,p}, \dots, \alpha_{2,2n-3}\}, \text{ for some } 3 \leq p < k.$$

Since $s_{1,r} = 0$ for all $2 \leq r < k$ we get

$$\sum_{\beta \in \mathbf{p}} s_\beta \leq s_{2,3} + \dots + s_{2,2n-3} \leq (s_{2,2} - 1) + s_{2,3} + \dots + s_{2,2n-3} \leq m - 1,$$

which is a contradiction. Similarly, for $\mathbf{p} \in \mathbf{D}_2^{\text{type}1}$ we get $\sum_{\beta \in \mathbf{p}} (s_\beta - t_\beta) \leq m - 1$. Hence $\mathbf{s} - \mathbf{t} \in S(\mathbf{D}, (m - 1)\omega_2)$ and the induction begins.

Assume that $s_\theta \neq 0$ and let \mathbf{s}^1 be the multi-exponent obtained from \mathbf{s} by replacing s_θ by $s_\theta - 1$. By induction there exists a multi-exponent $\mathbf{t}^1 \in S(\mathbf{D}, \omega_2)$ such that $\mathbf{r}^1 := \mathbf{s}^1 - \mathbf{t}^1 \in S(\mathbf{D}, (m - 1)\omega_2)$. If $\sum_{\beta \in R_2^+} t_\beta^1 \leq 1$ we set \mathbf{t} to be the multi-exponent obtained from \mathbf{t}^1 by replacing t_θ^1 by $t_\theta^1 + 1$. Then we get $\mathbf{t} \in S(\mathbf{D}, \omega_2)$ and $\mathbf{s} - \mathbf{t} = \mathbf{r}^1$. Otherwise we set \mathbf{r} to be the multi-exponent obtained from \mathbf{r}^1 by replacing r_θ^1 by $r_\theta^1 + 1$. Since $\sum_{\beta \in R_2^+} t_\beta^1 = 2$, we get $\sum_{\beta \in R_2^+} r_\beta \leq 2m - 2$ and therefore

$$\mathbf{s} = \mathbf{r} + \mathbf{t}^1, \text{ and } \mathbf{s} - \mathbf{t}^1 \in S(\mathbf{D}, (m - 1)\omega_2).$$

□

In order to cover the remaining special cases, we shall prove Lemma 4.3 (ii) for $n = i = 4$. Let $\mathbf{s} \in S(\mathbf{D}, m\omega_4)$. We will prove the Minkowski property by induction on $s_{4,4} + s_{1,7}$. If $s_{4,4} = s_{1,7} = 0$, we consider two cases.

Case 1: In this case we suppose that $s_{1,6}$, $s_{2,5}$ and $s_{3,4}$ are non-zero.

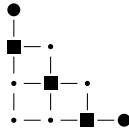

Then we define $\mathbf{t} \in S(\mathbf{D}, 2\omega_4)$ to be the multi-exponent with $t_{1,6} = t_{2,5} = t_{3,4} = 1$ and 0 else. It is immediate that the difference $\mathbf{s} - \mathbf{t} \in S(\mathbf{D}, (m - 2)\omega_4)$.

Case 2: In this case we suppose that one of the entries $s_{1,6}$, $s_{2,5}$ or $s_{3,4}$ is zero. Then there is a Dyck path \mathbf{p} such that \mathbf{s} is supported on \mathbf{p} and the statement is immediate.

So suppose that either $s_{4,4} \neq 0$ or $s_{1,7} \neq 0$. The proof in both cases is similar, so that we can assume $s_{4,4} \neq 0$.

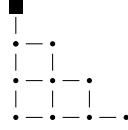

We set \mathbf{s}^1 to be the multi-exponent obtained from \mathbf{s} by replacing $s_{4,4}$ by $s_{4,4} - 1$. By induction we can find $\mathbf{t}^1 \in S(\mathbf{D}, 2\omega_4)$ such that $\mathbf{s}^1 - \mathbf{t}^1 \in S(\mathbf{D}, (m - 2)\omega_4)$. Now we define \mathbf{t} to be the multi-exponent obtained from \mathbf{t}^1 by replacing $t_{4,4}$ by $t_{4,4} + 1$ if the resulting element stays in $S(\mathbf{D}, 2\omega_4)$ and otherwise we set $\mathbf{t} = \mathbf{t}^1$. In either case $\mathbf{s} - \mathbf{t} \in S(\mathbf{D}, (m - 2)\omega_4)$.

Remark.

- (1) The set $S(\mathbf{D}, m\omega_i)$ does not satisfy the usual Minkowski sum property in general, e.g. the element $(m_\beta) \in S(\mathbf{D}, 2\omega_4)$ ($n = 4$) with $m_\beta = 1$ for $\beta \in \{\alpha_{1,6}, \alpha_{2,5}, \alpha_{3,4}\}$ and else 0 is not contained in $S(\mathbf{D}, \omega_4) + S(\mathbf{D}, \omega_4)$. Another example is the element $(m_\beta) \in S(\mathbf{D}, 2\omega_3)$ ($n = 4$) with $m_\beta = 1$ for $\beta \in \{\alpha_{1,3}, \alpha_{1,4}, \alpha_{1,6}, \alpha_{2,5}, \alpha_{3,3}\}$ and else 0.
- (2) The polytope $P(\mathbf{D}, \epsilon_i m\omega_i)$ is defined by inequalities with integer coefficients and hence the Minkowski property in Lemma 4.3 (ii) ensures that $P(\mathbf{D}, \epsilon_i m\omega_i)$ is a normal polytope for $1 \leq i \leq 3$ and n arbitrary or i arbitrary and $1 \leq n \leq 4$. The proof is exactly the same as in [12, Lemma 8.7].

Summarizing, we have proved Conjecture 4.3 for arbitrary n and $1 \leq i \leq 3$ or arbitrary i and $1 \leq n \leq 4$. Moreover the proof of the general case can be reduced to the proof of Lemma 4.3 (ii) and Lemma 4.3 (iii).

5. DYCK PATH, POLYTOPES AND PBW BASES FOR \mathfrak{so}_7

If the Lie algebra is of type \mathbf{B}_3 we shall associate to any dominant integral weight λ a normal polytope and prove that a basis of $\text{gr } V(\lambda)$ can be parametrized by the lattice points of this polytope. We emphasize at this point that the polytopes we will define for \mathbf{B}_3 are quasi compatible with the polytopes defined in Section 4.2; see Remark 5.1 for more details.

5.1. We use the following abbreviations:

$$\beta_1 := \alpha_{1,5}, \beta_2 := \alpha_{1,4}, \beta_3 := \alpha_{2,4}, \beta_4 := \alpha_{1,3}, \beta_5 := \alpha_{2,3}, \beta_6 := \alpha_{1,2}, \beta_7 := \alpha_{2,2}, \beta_8 := \alpha_{3,3}, \beta_9 := \alpha_{1,1}.$$

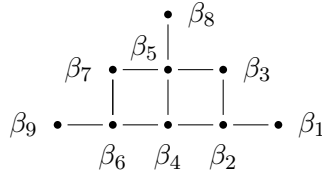

Let $\lambda = m_1\omega_1 + m_2\omega_2 + m_3\omega_3$, $s_i := s_{\beta_i}$ for $1 \leq i \leq 9$ and set $(a, b, c) := am_1 + bm_2 + cm_3$. We denote by $P(\lambda) \subseteq \mathbb{R}_+^9$ the polytope determined by the following inequalities:

- (1) $s_2 + s_3 + s_4 + s_8 + s_9 \leq (1, 1, 1)$
- (2) $s_3 + s_4 + s_5 + s_8 + s_9 \leq (1, 1, 1)$
- (3) $s_4 + s_5 + s_6 + s_8 + s_9 \leq (1, 1, 1)$
- (4) $s_5 + s_6 + s_7 + s_8 + s_9 \leq (1, 1, 1)$
- (5) $s_3 + s_5 + s_8 \leq (0, 1, 1)$
- (6) $s_5 + s_7 + s_8 \leq (0, 1, 1)$
- (7) $s_6 + s_7 + s_9 \leq (1, 1, 0)$
- (8) $s_7 \leq (0, 1, 0)$
- (9) $s_8 \leq (0, 0, 1)$
- (10) $s_9 \leq (1, 0, 0)$
- (11) $s_3 + s_4 + s_5 + s_6 + s_7 + s_8 + s_9 \leq (1, 2, 1)$
- (12) $s_1 + s_2 + s_3 + s_4 + s_5 + s_7 + s_9 \leq (1, 2, 1)$
- (13) $s_1 + s_3 + s_4 + s_5 + s_6 + s_7 + s_9 \leq (1, 2, 1)$
- (14) $s_2 + s_3 + s_4 + s_5 + s_7 + s_8 + s_9 \leq (1, 2, 1)$

$$\begin{aligned}
(15) \quad s_1 + s_2 + s_3 + s_4 + s_5 + s_6 + s_7 + 2s_9 &\leq & (17) \quad s_1 + s_2 + 2(s_3 + s_4 + s_5) + s_6 + s_7 + s_8 + 2s_9 &\leq \\
(2, 2, 1) & & (2, 3, 2) & \\
(16) \quad s_2 + s_3 + s_4 + s_5 + s_6 + s_7 + s_8 + 2s_9 &\leq & (18) \quad s_2 + 2(s_3 + s_4 + s_5) + s_6 + s_7 + 2(s_8 + s_9) &\leq \\
(2, 2, 1) & & (2, 3, 2) & \\
& & (19) \quad s_3 + s_4 + 2s_5 + s_6 + s_7 + 2s_8 + s_9 &\leq (1, 2, 2)
\end{aligned}$$

As before we set $S(\lambda) = P(\lambda) \cap \mathbb{Z}_+^9$.

Remark. Assume that $\lambda = m\omega_i$ for some $1 \leq i \leq 3$. If $i \neq 1$, then the polytope $P(\mathbf{D}, m\omega_i)$ defined in Section 4.2 coincides with the polytope given by the inequalities (1) – (19). If $i = 1$ these polytopes slightly differ in the following sense: the polytope $P(\mathbf{D}, m\omega_1)$ from Section 4.2 is determined by the inequalities

$$(1) \quad s_1 + s_2 + s_4 + s_6 \leq m \qquad (2) \quad s_2 + s_4 + s_6 + s_9 \leq m$$

whereas the above polytope can be simplified and is determined by the inequalities

$$(1) \quad s_1 + s_4 + s_6 + s_9 \leq m \qquad (2) \quad s_1 + s_2 + s_4 + s_9 \leq m$$

5.2. For the rest of this section we prove the following theorem.

Theorem. Let \mathfrak{g} be of type B_3 .

(1) The lattice points $S(\lambda)$ parametrize a basis of $V(\lambda)$ and $\text{gr } V(\lambda)$ respectively. In particular,

$$\{X^{\mathbf{s}} v_\lambda \mid \mathbf{s} \in S(\lambda)\}$$

forms a basis of $\text{gr } V(\lambda)$.

(2) The character and graded q -character respectively is given by

$$\text{ch } V(\lambda) = \sum_{\mu \in \mathfrak{h}^*} |S(\lambda)^\mu| e^\mu$$

$$\text{ch}_q \text{gr } V(\lambda) = \sum_{\mathbf{s} \in S(\lambda)} e^{\lambda - \text{wt}(\mathbf{s})} q^{\sum s_\beta}.$$

(3) We have an isomorphism of $S(\mathfrak{n}^-)$ -modules

$$\text{gr } V(\lambda + \mu) \cong S(\mathfrak{n}^-)(v_\lambda \otimes v_\mu) \subseteq \text{gr } V(\lambda) \otimes \text{gr } V(\mu)$$

As in Section 4 we can deduce the above theorem from the following lemma.

Lemma.

(i) Let $\lambda, \mu \in P^+$. We have

$$S(\lambda + \mu) = S(\lambda) + S(\mu)$$

(ii) For all $\lambda \in P^+$:

$$\dim V(\lambda) = |S(\lambda)|$$

The proof of Lemma 5.2 (i) is given in Section 5.3 and the proof of Lemma 5.2 (ii) can be found in Section 5.4.

5.3. Proof of Lemma 5.2 (i). For this part of the lemma it is enough to prove that $S(\lambda) = S(\lambda - \omega_j) + S(\omega_j)$ where j is the minimal integer such that $\lambda(\alpha_j^\vee) \neq 0$. If $j = 3$, many of the inequalities are redundant and the polytope can be simply described by the inequalities

$$s_1 + s_2 + s_3 + s_4 + s_5 \leq (0, 0, 1), \quad s_2 + s_3 + s_4 + s_5 + s_8 \leq (0, 0, 1).$$

The proof of the lemma in that case is obvious. If $j = 2$, there are again redundant inequalities and the polytope can simply be described by the inequalities (1) – (4), (7), (9) – (10) and (15) – (16). A straightforward calculation proves the proposition in that case. So let $j = 1$ and $\mathbf{s} = (s_i)_{1 \leq i \leq 9} \in S(\lambda)$. We will consider several cases.

Case 1: Assume that $s_9 \neq 0$ and let $\mathbf{t} = (t_i)_{1 \leq i \leq 9}$ be the multi-exponent given by $t_9 = 1$ and $t_j = 0$ otherwise. It follows immediately $\mathbf{t} \in S(\omega_1)$ and $\mathbf{s} - \mathbf{t} \in S(\lambda - \omega_1)$.

Case 2: In this case we suppose that $s_9 = 0$ and $s_2, s_6 \neq 0$.

Case 2.1: If in addition $s_3 + s_4 + s_5 + s_8 < (1, 1, 1)$ we let $\mathbf{t} = (t_i)_{1 \leq i \leq 9}$ to be the multi-exponent given by $t_2 = t_6 = 1$ and $t_j = 0$ otherwise. It is easy to show that $\mathbf{t} \in S(\omega_1)$ and $\mathbf{s} - \mathbf{t} \in S(\lambda - \omega_1)$, since $\mathbf{s} - \mathbf{t} \notin S(\lambda - \omega_1)$ forces $s_3 + s_4 + s_5 + s_8 = (1, 1, 1)$.

Case 2.2: Now we suppose that $s_3 + s_4 + s_5 + s_8 = (1, 1, 1)$. Together with (5) we obtain $s_4 \geq m_1 > 0$. We let $\mathbf{t} = (t_i)_{1 \leq i \leq 9}$ to be the multi-exponent with $t_4 = 1$ and $t_j = 0$ otherwise. Suppose that $\mathbf{s} - \mathbf{t} \notin S(\lambda - \omega_1)$, which is only possible if (4), (7), (15) or (16) is violated. Assume that (4) is violated, which means $s_5 + s_6 + s_7 + s_8 = (1, 1, 1)$. We obtain

$$(s_3 + s_4 + s_5 + s_8) + (s_5 + s_6 + s_7 + s_8) = s_3 + s_4 + 2s_5 + s_6 + s_7 + 2s_8 = (2, 2, 2),$$

which is a contradiction to (19). Assume that (7) is violated, which means $s_6 + s_7 = (1, 1, 0)$. We get

$$(s_3 + s_4 + s_5 + s_8) + (s_6 + s_7) = (2, 2, 1),$$

which is a contradiction to (11). In the remaining two cases (inequality (15) and (16) respectively is violated) we obtain similarly contradictions to (17) and (18) respectively.

Case 3: Assume that $s_2 = s_9 = 0$ and $s_6 \neq 0$. In this case many inequalities are redundant. In particular, for a multi-exponent \mathbf{t} with $t_j \leq s_j$ for $1 \leq j \leq 9$ we have $\mathbf{s} - \mathbf{t} \in S(\lambda - \omega_1)$ if and only if $\mathbf{s} - \mathbf{t}$ satisfies (2) – (11), (13) and (19). To be more precise,

$$\mathbf{s} - \mathbf{t} \text{ satisfies (2)} \Rightarrow \mathbf{s} - \mathbf{t} \text{ satisfies (1)}$$

$$\mathbf{s} - \mathbf{t} \text{ satisfies (13)} \Rightarrow \mathbf{s} - \mathbf{t} \text{ satisfies (12), (15)}$$

$$\mathbf{s} - \mathbf{t} \text{ satisfies (11)} \Rightarrow \mathbf{s} - \mathbf{t} \text{ satisfies (14), (16)}$$

$$\mathbf{s} - \mathbf{t} \text{ satisfies (2) and (13)} \Rightarrow \mathbf{s} - \mathbf{t} \text{ satisfies (17)}$$

$$\mathbf{s} - \mathbf{t} \text{ satisfies (2) and (11)} \Rightarrow \mathbf{s} - \mathbf{t} \text{ satisfies (18)}$$

Case 3.1: If in addition $s_3 + s_4 + s_5 + s_8 < (1, 1, 1)$ we let $\mathbf{t} = (t_i)_{1 \leq i \leq 9}$ to be the multi-exponent given by $t_6 = 1$ and $t_j = 0$ otherwise. It is straightforward to check that $\mathbf{t} \in S(\omega_1)$ and $\mathbf{s} - \mathbf{t} \in S(\lambda - \omega_1)$.

Case 3.2: If $s_3 + s_4 + s_5 + s_8 = (1, 1, 1)$ we let $\mathbf{t} = (t_i)_{1 \leq i \leq 9}$ to be the multi-exponent with $t_4 = 1$ and $t_j = 0$ otherwise. Note that $\mathbf{s} - \mathbf{t} \notin S(\lambda - \omega_1)$ is only possible if (4) or (7) is violated. If (4) and (7) respectively is violated we get similarly as in Case 2.2 a contradiction to (19) and (11) respectively.

Case 4: Assume that $s_6 = s_9 = 0$ and $s_2 \neq 0$. This case works similar to Case 3 and will be omitted.

Case 5: In this case we suppose $s_6 = s_9 = s_2 = 0$ and simplify further the defining inequalities of the polytope. As in Case 3, for a multi-exponent \mathbf{t} with $t_j \leq s_j$ for $1 \leq j \leq 9$ we have $\mathbf{s} - \mathbf{t} \in S(\lambda - \omega_1)$ if and only if $\mathbf{s} - \mathbf{t}$ satisfies (2), (5), (6), (8) – (11), (13) and (19). To be more precise,

$$\mathbf{s} - \mathbf{t} \text{ satisfies (2)} \Rightarrow \mathbf{s} - \mathbf{t} \text{ satisfies (3)}$$

$$\mathbf{s} - \mathbf{t} \text{ satisfies (6)} \Rightarrow \mathbf{s} - \mathbf{t} \text{ satisfies (4)}$$

$$\mathbf{s} - \mathbf{t} \text{ satisfies (8)} \Rightarrow \mathbf{s} - \mathbf{t} \text{ satisfies (7)}$$

Case 5.1: We suppose that $s_4 \neq 0$ and let $\mathbf{t} = (t_i)_{1 \leq i \leq 9}$ to be the multi-exponent given by $t_4 = 1$ and $t_j = 0$ otherwise. The desired property follows immediately.

Case 5.2: Let $s_4 = 0$. Then again we can simplify the inequalities and obtain that $\mathbf{s} - \mathbf{t} \in S(\lambda - \omega_1)$ if and only if $\mathbf{s} - \mathbf{t}$ satisfies (5), (6), (8) – (10), and (13). To be more precise,

$$\mathbf{s} - \mathbf{t} \text{ satisfies (5)} \Rightarrow \mathbf{s} - \mathbf{t} \text{ satisfies (2)}$$

$$\mathbf{s} - \mathbf{t} \text{ satisfies (5) and (8)} \Rightarrow \mathbf{s} - \mathbf{t} \text{ satisfies (11)}$$

$$\mathbf{s} - \mathbf{t} \text{ satisfies (5) and (8)} \Rightarrow \mathbf{s} - \mathbf{t} \text{ satisfies (19)}$$

Case 5.2.1: If $s_1 = 0$ we already have $\mathbf{s} \in S(\lambda - m_1\omega_1)$. If $s_1 \neq 0$, let $\mathbf{t} = (t_i)_{1 \leq i \leq 9}$ be the multi-exponent with $t_1 = 1$ and $t_j = 0$ otherwise. It follows immediately $\mathbf{t} \in S(\omega_1)$ and $\mathbf{s} - \mathbf{t} \in S(\lambda - \omega_1)$.

Remark. The polytope $P(\lambda)$ is defined by inequalities with integer coefficients and hence the Minkowski property in Lemma 5.2 (i) ensures that $P(\lambda)$ is a normal polytope. The proof is exactly the same as in [12, Lemma 8.7].

5.4. Proof of Lemma 5.2 (ii). We consider the convex lattice polytopes $P_i := P(\omega_i) \subseteq \mathbb{R}_+^9$ for $1 \leq i \leq 3$. By [3, Problem 3, pg. 164] there exists a 3-variate polynomial $E(T_1, T_2, T_3)$ of total degree ≤ 9 such that

$$E(m_1, m_2, m_3) = |(m_1P_1 + m_2P_2 + m_3P_3) \cap \mathbb{Z}_+^9|, \text{ for non-negative integers } m_1, m_2, m_3.$$

By Lemma 5.2 (i) we get

$$E(m_1, m_2, m_3) = |S(\lambda)|, \text{ for non-negative integers } m_1, m_2, m_3$$

and by Weyl's dimension formula, we know that there is another 3-variate polynomial $W(T_1, T_2, T_3)$ of total degree ≤ 9 such that

$$W(m_1, m_2, m_3) = \dim V(\lambda).$$

The polynomial is given by

$$W(T_1, T_2, T_3) = \frac{1}{720} (T_1 + 1)(T_2 + 1)(T_2 + 1)(T_1 + 2T_2 + T_3 + 4)(2T_1 + 2T_2 + T_3 + 5) \\ (T_1 + T_2 + T_3 + 3)(T_1 + T_2 + 2)(T_2 + T_3 + 2)(2T_2 + T_3 + 3).$$

Hence it will be enough to prove that both polynomials coincide. By using the code given in Section 7.3, written in Java, we can deduce $E(\lambda_0, \lambda_1, \lambda_2) = W(\lambda_0, \lambda_1, \lambda_2)$ for all $(\lambda_0, \lambda_1, \lambda_2) \in \mathbb{Z}_+^3$ with $\lambda_0 + \lambda_1 + \lambda_2 \leq 9$. We claim that this fact already implies $E(T_1, T_2, T_3) = W(T_1, T_2, T_3)$. Let $I = \{(\lambda_0, \lambda_1, \lambda_2) \in \mathbb{Z}_+^3 \mid \lambda_0 + \lambda_1 + \lambda_2 \leq 9\}$ and write

$$E(T_1, T_2, T_3) = \sum_{(n,m,k) \in I} e_{n,m,k} T_1^n T_2^m T_3^k, \quad W(T_1, T_2, T_3) = \sum_{(n,m,k) \in I} w_{n,m,k} T_1^n T_2^m T_3^k$$

We obtain with our assumption that

$$\sum_{(n,m,k) \in I} (e_{n,m,k} - w_{n,m,k}) \lambda_0^n \lambda_1^m \lambda_2^k = 0.$$

We can translate this into a system of linear equations where the underlying matrix is given by

$$(\lambda_0^{\mu_0} \lambda_1^{\mu_1} \lambda_2^{\mu_2})_{\lambda, \mu \in I}.$$

This matrix is invertible by [6, Theorem 1] and therefore the claim is proven.

6. CONSTRUCTION OF FAVOURABLE MODULES

In [12] the notion of favourable modules has been introduced and several classes of examples for type \mathbf{A}_n , \mathbf{C}_n and \mathbf{G}_2 have been discussed. This section is dedicated to give further examples of favourable modules in type \mathbf{B}_n . Let us first recall the definition.

6.1. We fix an ordered basis $\{x_1, \dots, x_N\}$ of \mathfrak{n}^- and an induced homogeneous lexicographic order $<$ on the monomials in $\{x_1, \dots, x_N\}$. Let M be any finite-dimensional cyclic $\mathbf{U}(\mathfrak{n}^-)$ -module with cyclic vector v_M and let

$$X^{\mathbf{s}} v_M = x_1^{s_1} \dots x_N^{s_N} v_M \in M,$$

where $\mathbf{s} \in \mathbb{Z}_+^N$ is a multi-exponent. The following definition is due to Vinberg.

Definition. A pair (M, \mathbf{s}) is called essential if

$$X^{\mathbf{s}} v_M \notin \text{span}\{X^{\mathbf{q}} v_M \mid \mathbf{q} < \mathbf{s}\}.$$

If the pair (M, \mathbf{s}) is essential, then \mathbf{s} is called an essential multi-exponent and $X^{\mathbf{s}}$ is called an essential monomial in M . The set of all essential monomials are denoted by $\text{es}(M) \subseteq \mathbb{Z}_+^N$. We introduce subspaces $F_{\mathbf{s}}(M)^- \subseteq F_{\mathbf{s}}(M) \subseteq M$:

$$F_{\mathbf{s}}(M)^- = \text{span}\{X^{\mathbf{q}} v_M \mid \mathbf{q} < \mathbf{s}\}, \quad F_{\mathbf{s}}(M) = \text{span}\{X^{\mathbf{q}} v_M \mid \mathbf{q} \leq \mathbf{s}\}.$$

These subspaces define an increasing filtration on M and the associated graded space with respect to this filtration is defined by

$$M^t = \bigoplus_{\mathbf{s} \in \mathbb{Z}_+^N} F_{\mathbf{s}}(M)^- / F_{\mathbf{s}}(M).$$

Similar as in Section 3 we can define the PBW filtration on M and the associated graded space $\text{gr } M$ with respect to the PBW filtration. The following proposition follows from the construction of M^t and $\text{gr } M$ (see also [12, Proposition.1.5]).

Proposition. The set $\{X^{\mathbf{s}} \mid \mathbf{s} \in \text{es}(M)\}$ forms a basis of M^t , $\text{gr } M$ and M .

6.2. We recall the definition of favourable modules.

Definition. We say that a finite-dimensional cyclic $\mathbf{U}(\mathfrak{n}^-)$ -module M is favourable if there exists an ordered basis x_1, \dots, x_N of \mathfrak{n}^- and an induced homogeneous monomial order on the PBW basis such that

- There exists a normal polytope $P(M) \subset \mathbb{R}^N$ such that $\text{es}(M)$ is exactly the set $S(M)$ of lattice points in $P(M)$.
- $\forall k \in \mathbb{N} : \dim \mathbf{U}(\mathfrak{n}^-) \underbrace{(v_M \otimes \dots \otimes v_M)}_k = \underbrace{|S(M) + \dots + S(M)|}_k$.

Let N be a complex algebraic unipotent group such that \mathfrak{n}^- is the corresponding Lie algebra. Similarly on the group level, we have a commutative unipotent group $\mathrm{gr} N$ with Lie algebra $\mathrm{gr} \mathfrak{n}^-$ acting on $\mathrm{gr} M$ and M^t . We associate to the action of the unipotent groups projective varieties, which are called flag varieties in analogy to the classical highest weight orbits (see [12] for details)

$$\mathfrak{F}(M) = \overline{N \cdot [v_M]} \subseteq \mathbb{P}(M), \quad \mathfrak{F}(\mathrm{gr} M) = \overline{\mathrm{gr} N \cdot [v_M]} \subseteq \mathbb{P}(\mathrm{gr} M), \quad \mathfrak{F}(M^t) = \overline{\mathrm{gr} N \cdot [v_M]} \subseteq \mathbb{P}(M^t).$$

The following theorem proved in [12] gives a motivation for constructing favourable modules by showing that the flag varieties associated to favourable modules have nice properties.

Theorem. Let M be a favourable \mathfrak{n}^- -module.

- (1) $\mathfrak{F}(M^t) \subseteq \mathbb{P}(M^t)$ is a toric variety.
- (2) There exists a flat degeneration of $\mathfrak{F}(M)$ into $\mathfrak{F}(\mathrm{gr} M)$, and for both there exists a flat degeneration into $\mathfrak{F}(M^t)$.
- (3) The projective flag varieties $\mathfrak{F}(M) \subseteq \mathbb{P}(M)$ and its abelianized versions $\mathfrak{F}(\mathrm{gr} M) \subseteq \mathbb{P}(\mathrm{gr} M)$ and $\mathfrak{F}(M^t) \subseteq \mathbb{P}(M^t)$ are projectively normal and arithmetically Cohen–Macaulay varieties.
- (4) The polytope $P(M)$ is the Newton–Okounkov body for the flag variety and its abelianized version, i.e. $\Delta(\mathfrak{F}(M)) = P(M) = \Delta(\mathfrak{F}(\mathrm{gr} M))$.

6.3. In [12, Section 8] the authors provided concrete classes of examples of favourable modules for the types A_n , C_n and G_2 . The following theorem gives us classes of examples of favourable modules in type B_n (including multiples of the adjoint representation).

Theorem. Let \mathfrak{g} be the Lie algebra of type B_n and λ be a dominant integral weight satisfying one of the following

- (1) $n = 3$ and λ is arbitrary
- (2) n is arbitrary and $\lambda = m\omega_1$ or $\lambda = m\omega_2$
- (3) n is arbitrary and $\lambda = 2m\omega_3$ or $n = 4$ and $\lambda = 2m\omega_4$

Then there exists an ordered basis on \mathfrak{n}^- and an induced homogeneous monomial order on the PBW basis such that $V(\lambda)$ is a favourable \mathfrak{n}^- -module.

Proof. We will show that $V(\lambda)$ satisfies the properties from Definition 6.2. We consider the appropriate polytopes from (4.2) and $P(\lambda)$ from Section 5. These polytopes are normal by Remark 4.5 and Remark 5.3 and therefore the natural candidates for showing the properties from Definition 6.2. For simplicity we will denote these polytopes by $P(\lambda)$ since it will be clear from the context which polytope we mean. The second property follows immediately since on the one hand $\mathbf{U}(\mathfrak{n}^-)(v_\lambda \otimes \cdots \otimes v_\lambda) \cong V(k\lambda)$ and on the other hand the k -fold Minkowski sum parametrizes a basis of $V(k\lambda)$ by Theorem 5.2 (1), Lemma 5.2 (i), Conjecture 4.3 (1) (which is proved in these cases) and Lemma 4.3 (ii). Hence it remains to prove that $\mathrm{es}(V(\lambda))$ (with respect to a fixed order) is exactly the set $S(\lambda)$. Let $\lambda = \sum_{j=1}^n m_j a_j \omega_j$. By [12, Proposition 1.11] we know that

$$\mathrm{es}(V(\lambda)) \supseteq \underbrace{\mathrm{es}(V(a_1\omega_1)) + \cdots + \mathrm{es}(V(a_1\omega_1))}_{m_1} + \cdots + \underbrace{\mathrm{es}(V(a_n\omega_n)) + \cdots + \mathrm{es}(V(a_n\omega_n))}_{m_n}, \quad (6.1)$$

and hence it is enough to show that there exists an ordered basis on \mathfrak{n}^- and an induced homogeneous monomial order on a PBW basis such that $\mathrm{es}(V(a_j\omega_j)) = S(a_j\omega_j)$ for all j with $m_j \neq 0$ (recall from Proposition 6.1 that $|\mathrm{es}(V(\lambda))| = |S(\lambda)|$). Suppose first that we are in case (2) or (3) (then $a_j = 1$ and $a_k = 0$ for all $k \neq j$ in case (2) and in case (3) we have $a_3 = 2$ respectively $a_4 = 2$ and $a_k = 0$ else). Then we choose the order given in Section 4.4 (we ordered the roots in the Hasse

diagram from the bottom to the top and from left to right) and the induced homogeneous reverse lexicographic order on a PBW basis. By our results we obtain for $\mathbf{s} \notin S(a_j\omega_j)$ that

$$X^{\mathbf{s}} v_{a_j\omega_j} \in \text{span}\{X^{\mathbf{q}} v_{a_j\omega_j} \mid \mathbf{q} \prec \mathbf{s}\}$$

and hence $\text{es}(V(a_j\omega_j)) \subseteq S(a_j\omega_j)$. Since these sets have the same cardinality we are done. Suppose now that we are in case (1) ($a_j = 1$ for all j). Then we choose the following order on the positive roots

$$\beta_7 \succ \beta_6 \succ \beta_1 \succ \beta_2 \succ \beta_3 \succ \beta_4 \succ \beta_5 \succ \beta_8 \succ \beta_9.$$

Similar as in Section 4.4 we can prove for all $\mathbf{s} \notin S(\omega_j)$ that

$$X^{\mathbf{s}} v_{\omega_j} \in \text{span}\{X^{\mathbf{q}} v_{\omega_j} \mid \mathbf{q} \prec \mathbf{s}\},$$

which finishes the proof of the theorem. \square

7. APPENDIX

In this section we want to complete the proof of Proposition 4.5 for $i = 3$. Moreover, we give a proof of the second part of Theorem 3.3 for type \mathbf{G}_2 .

7.1. We consider the Lie algebra of type \mathbf{G}_2 and the following order on the positive roots:

$$\beta_1 := 3\alpha_1 + 2\alpha_2 \succ \beta_2 := 3\alpha_1 + \alpha_2 \succ \beta_3 := 2\alpha_1 + \alpha_2 \succ \beta_4 := \alpha_1 + \alpha_2 \succ \beta_5 := \alpha_2 \succ \beta_6 := \alpha_1.$$

As before, we extend the above order to the induced homogeneous reverse lexicographic order on the monomials in $S(\mathfrak{n}^-)$. The order is chosen in a way such that Lemma 4.4 can be applied. Let $\lambda = m_1\omega_1 + m_2\omega_2$, $s_i := s_{\beta_i}$ for $1 \leq i \leq 6$ and set $(a, b) := am_1 + bm_2$. It has been proved in [16] that the lattice points $S(\lambda)$ of the following polytope $P(\lambda)$ parametrize a basis of $\text{gr } V(\lambda)$:

$$\begin{array}{ll} (1) & s_6 \leq (1, 0) \\ (2) & s_5 \leq (0, 1) \\ (3) & s_2 + s_3 + s_6 \leq (1, 1) \\ (4) & s_3 + s_4 + s_6 \leq (1, 1) \\ (5) & s_4 + s_5 + s_6 \leq (1, 1) \\ (6) & s_1 + s_2 + s_3 + s_4 + s_5 \leq (1, 2) \\ (7) & s_2 + s_3 + s_4 + s_5 + s_6 \leq (1, 2) \end{array}$$

Proposition. We have $\text{gr } V(\lambda) \cong S(\mathfrak{n}^-)/\mathbf{I}_\lambda$, where

$$\mathbf{I}_\lambda = S(\mathfrak{n}^-)(\mathbf{U}(\mathfrak{n}^+) \circ \text{span}\{x_{-\beta}^{\lambda(\beta^\vee)+1} \mid \beta \in R^+\}).$$

Proof. Since we have a surjective map

$$S(\mathfrak{n}^-)/\mathbf{I}_\lambda \longrightarrow \text{gr } V(\lambda),$$

it will be enough to show by the result of [16] that the set $\{X^{\mathbf{s}} v_\lambda \mid \mathbf{s} \in S(\lambda)\}$ generates $S(\mathfrak{n}^-)/\mathbf{I}_\lambda$. As in Section 4 we will simply show that any multi-exponent \mathbf{s} violating one of the inequalities (1) – (7) can be written as a sum of strictly smaller monomials. It means there exists constants $c_{\mathbf{t}} \in \mathbb{C}$ such that

$$X^{\mathbf{s}} + \sum_{\mathbf{t} \prec \mathbf{s}} c_{\mathbf{t}} X^{\mathbf{t}} \in \mathbf{I}_\lambda.$$

The proof for all inequalities is similar and therefore we provide the proof only when \mathbf{s} violates (7). So let \mathbf{s} be a multi-exponent with $s_1 = 0$ and $s_2 + s_3 + s_4 + s_5 + s_6 > (1, 2)$. We apply the operators $\partial_{\beta_3}^{s_4+s_6} \partial_{\beta_2}^{s_5}$ on X_{β_1} and obtain

$$\partial_{\beta_3}^{s_4+s_6} \partial_{\beta_2}^{s_5} X_{\beta_1}^{s_2+s_3+s_4+s_5+s_6} = c X_{\beta_1}^{s_2+s_3} X_{\beta_4}^{s_4+s_6} X_{\beta_5}^{s_5} \in \mathbf{I}_\lambda, \text{ for some non-zero constant } c \in \mathbb{C}.$$

Further we apply with $\partial_{\beta_5}^{s_2} \partial_{\beta_4}^{s_3}$ on $X_{\beta_1}^{s_2+s_3} X_{\beta_4}^{s_4+s_6} X_{\beta_5}^{s_5}$ and obtain with Lemma 4.4 that there exists constants $c_{\mathbf{t}} \in \mathbb{C}$ such that

$$\partial_{\beta_5}^{s_2} \partial_{\beta_4}^{s_3} X_{\beta_1}^{s_2+s_3} X_{\beta_4}^{s_4+s_6} X_{\beta_5}^{s_5} = X_{\beta_2}^{s_2} X_{\beta_3}^{s_3} X_{\beta_4}^{s_4+s_6} X_{\beta_5}^{s_5} + \sum_{\mathbf{t} \prec \mathbf{s}} c_{\mathbf{t}} X^{\mathbf{t}} \in \mathbf{I}_{\lambda}. \quad (7.1)$$

Finally, we act with the operator $\partial_{\beta_5}^{s_6}$ on (7.1) and get once more with Lemma 4.4 the desired property. \square

7.2. Proof of Proposition 4.5 for $i = 3$: Recall that a bold dot (resp. square) in the Hasse diagram indicates that the corresponding entry of \mathbf{s} is zero (resp. non-zero). Let $i = 3$ and $\mathbf{s} \in S(\mathbf{D}, m\omega_3)$. If $s_{3,j} = 0$ for all $3 \leq j \leq 2n-3$ the statement of the proposition can be easily deduced from the $i = 2$ case. So we can suppose for the rest of the proof that $s_{3,j} \neq 0$ for some $3 \leq j \leq 2n-3$. In contrast to the $i = 2$ case we will construct a multi-exponent $\mathbf{t} \in S(\mathbf{D}, p\omega_3)$ such that $\mathbf{s} - \mathbf{t} \in S(\mathbf{D}, (m-p)\omega_3)$ where $p = 1$ or $p = 2$. A similar induction argument as in the $i = 2$ case shows that it is enough to prove the statement for all multi-exponents \mathbf{s} with $s_{\theta} = 0$. Since $s_{\theta} = 0$ it is sufficient to check the defining inequalities of the polytope for all $\mathbf{p} \in \mathbf{D} \setminus \mathbf{q}$, where \mathbf{q} is the unique type 2 Dyck path with $\theta \in \mathbf{q}$. In other words

$$\sum_{\beta \in \mathbf{p}} (s_{\beta} - t_{\beta}) \leq M_{\mathbf{p}}((m-p)\omega_3), \quad \forall \mathbf{p} \in \mathbf{D} \setminus \mathbf{q} \Rightarrow \mathbf{s} - \mathbf{t} \in S(\mathbf{D}, (m-p)\omega_3).$$

We consider several cases.

Case 1: In this case we suppose $s_{3,2n-3} \neq 0$.

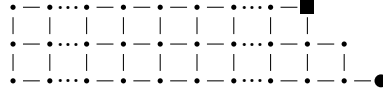

Let $\mathbf{t} \in \mathbf{T}(1)$ be the multi-exponent with $\text{supp}(\mathbf{t}) = \{\alpha_{3,2n-3}, \alpha_{k,3}\}$, where $k = \min\{1 \leq j \leq 2 \mid s_{j,3} \neq 0\}$. If k exists, it is easy to see that $\mathbf{t} \in S(\mathbf{D}, \omega_3)$ and $\mathbf{s} - \mathbf{t} \in S(\mathbf{D}, (m-1)\omega_3)$. So suppose that $s_{1,3} = s_{2,3} = 0$.

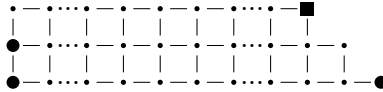

Now we consider two additional cases.

Case 1.1: First we assume that $\sum_{k=3}^{2n-4} s_{3,k} = m$ (sum over the unfilled circles and the unfilled square), which forces $s_{3,3} \neq 0$.

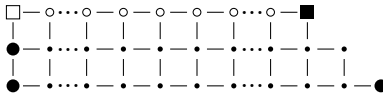

Then we define $\mathbf{t} \in \mathbf{T}(1)$ to be the multi-exponent with $\text{supp}(\mathbf{t}) = \{\alpha_{3,2n-3}, \alpha_{3,3}\}$. We shall prove that $\mathbf{s} - \mathbf{t} \in S(\mathbf{D}, (m-1)\omega_3)$. For any $\mathbf{p} \in \mathbf{D}^{\text{type } 1}$ we obviously have $\sum_{\beta \in \mathbf{p}} (s_{\beta} - t_{\beta}) \leq m-1$. So let $\mathbf{p} = \mathbf{p}_1 \cup \mathbf{p}_2 \in \mathbf{D}^{\text{type } 2} \setminus \mathbf{q}$. If $\alpha_{3,3} \in \mathbf{p}_2$, there is nothing to show. Otherwise we get that \mathbf{p}_2 is of the form

$$\mathbf{p}_2 = \{\alpha_{2,3}, \alpha_{2,4} \dots \alpha_{2,p}, \alpha_{3,p}, \alpha_{3,p+1}, \dots \alpha_{3,2n-3}\}, \quad 3 < p \leq 2n-3$$

and

$$\sum_{\beta \in \mathbf{p}_2} s_\beta \leq m = s_{2,3} + \sum_{k=3}^{2n-4} s_{3,k}.$$

It follows

$$\sum_{\beta \in \mathbf{p}_1} (s_\beta - t_\beta) + \sum_{\beta \in \mathbf{p}_2} (s_\beta - t_\beta) \leq \sum_{\beta \in \mathbf{p}_1} (s_\beta - t_\beta) + s_{2,3} + \sum_{k=3}^{2n-3} (s_{3,k} - t_{3,k}) \leq 2(m-1).$$

Case 1.2: It remains to consider the case $\sum_{k=3}^{2n-4} s_{3,k} \leq m-1$. Since $s_{1,3} = s_{2,3} = 0$ it is enough to construct a multi-exponent $\mathbf{t} \in S(\mathbf{D}, \omega_3)$ such that

$$\sum_{\beta \in \mathbf{p}} (s_\beta - t_\beta) \leq M_{\mathbf{p}}((m-1)\omega_3), \quad \forall \mathbf{p} \in \mathbf{D}_2^{\text{type } 1} \cup \mathbf{D}^{\text{type } 2}. \quad (7.2)$$

We define $\mathbf{t} \in \mathbf{T}(1)$ to be the multi-exponent with $\text{supp}(\mathbf{t}) = \{\alpha_{3,2n-3}\}$ if $s_{1,2n-2} = s_{2,2n-2} = 0$ and otherwise $\text{supp}(\mathbf{t}) = \{\alpha_{3,2n-3}, \alpha_{k,2n-2}\}$, where $k = \max\{1 \leq j \leq 2 \mid s_{j,2n-2} \neq 0\}$. In either case $\mathbf{t} \in S(\mathbf{D}, \omega_3)$ and if $s_{1,2n-2} = s_{2,2n-2} = 0$ or $s_{2,2n-2} \neq 0$ it is easy to verify that (7.2) holds. So suppose that $s_{2,2n-2} = 0$, $s_{1,2n-2} \neq 0$ and let $\mathbf{p} \in \mathbf{D}_2^{\text{type } 1} \cup \mathbf{D}^{\text{type } 2}$.

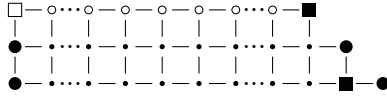

If $\mathbf{p} \in \mathbf{D}_2^{\text{type } 1}$ the statement follows from $\alpha_{3,2n-3} \in \mathbf{p}$. So let again $\mathbf{p} = \mathbf{p}_1 \cup \mathbf{p}_2 \in \mathbf{D}^{\text{type } 2} \setminus \mathbf{q}$. If $\alpha_{1,2n-2} \in \mathbf{p}_1$, we are done. Otherwise set

$$\bar{\mathbf{p}}_1 = \mathbf{p}_1 \setminus \{\alpha_{1,3}, \alpha_{2,2n-2}\} \cup \{\alpha_{3,2n-3}\}, \quad \bar{\mathbf{p}}_2 = \mathbf{p}_2 \setminus \{\alpha_{2,3}\} \cup \{a_{1,4}\}.$$

This yields $\bar{\mathbf{p}}_1, \bar{\mathbf{p}}_2 \in \mathbf{D}_2^{\text{type } 1}$ and therefore

$$\sum_{\beta \in \mathbf{p}_1} (s_\beta - t_\beta) + \sum_{\beta \in \mathbf{p}_2} (s_\beta - t_\beta) \leq \sum_{\beta \in \bar{\mathbf{p}}_1} (s_\beta - t_\beta) + \sum_{\beta \in \bar{\mathbf{p}}_2} (s_\beta - t_\beta) \leq (m-1) + (m-1).$$

This finishes Case 1; so from now on we can assume that $s_{3,2n-3} = 0$.

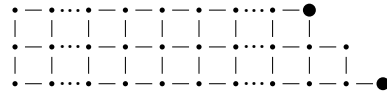

Hence we have simplified the situation to the following

$$\sum_{\beta \in \mathbf{p}} (s_\beta - t_\beta) \leq M_{\mathbf{p}}((m-p)\omega_3), \quad \forall \mathbf{p} \in \mathbf{D}_1^{\text{type } 1} \cup \tilde{\mathbf{D}}_2^{\text{type } 1} \cup \mathbf{D}^{\text{type } 2} \setminus \mathbf{q} \Rightarrow \mathbf{s} - \mathbf{t} \in S(\mathbf{D}, (m-p)\omega_3), \quad (7.3)$$

where $\tilde{\mathbf{D}}_2^{\text{type } 1} = \{\mathbf{p} \in \mathbf{D}_2^{\text{type } 1} \mid \alpha_{2,2n-3} \in \mathbf{p}\}$. Let \mathbf{s}' be the multi-exponent obtained from \mathbf{s} by setting all entries s_β with $\beta \in R_3^+(2n-4)$ to zero and $\mathbf{t}' = (t'_\beta)$ be the multi-exponent associated to \mathbf{s}' . By Lemma 4.5 we obtain for all $\mathbf{p} \in \mathbf{D}_1^{\text{type } 1}$

$$\sum_{\beta \in \mathbf{p}} (s_\beta - t'_\beta) \leq m-1. \quad (7.4)$$

Recall that $s_{3,j} \neq 0$ for some $3 \leq j \leq 2n-3$ and hence $t'_{3,k} \neq 0$ for some $3 \leq k \leq 2n-4$. So we consider the following cases which can appear.

Case 2: Suppose that $\sum_{\beta} t'_{\beta} = 3$. In this case there exists $3 \leq j_3 < j_2 < j_1 \leq 2n-4$ such that $t_{1,j_1} = t_{2,j_2} = t_{3,j_3} = 1$ (see the unfilled squares below).

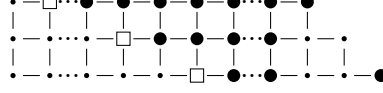

Let $\mathbf{p} \in \widetilde{\mathbf{D}}_2^{\text{type 1}}$ of the following form

$$\mathbf{p} = \{\alpha_{1,4}, \dots, \alpha_{1,p}, \alpha_{2,p}, \dots, \alpha_{2,2n-3}, \alpha_{3,2n-3}\}.$$

We suppose that $j_1 > p > j_2$, because otherwise there is nothing to show. This yields $s_{2,p} = \dots = s_{2,2n-4} = 0$ and hence

$$\sum_{\beta \in \mathbf{p}} (s_{\beta} - t'_{\beta}) \leq (s_{1,4} - t'_{1,4}) + \dots + (s_{1,2n-3} - t'_{1,2n-3}) + (s_{2,2n-3} - t'_{2,2n-3}) \leq m-1.$$

Similar arguments show

$$\sum_{\beta \in \mathbf{p}} (s_{\beta} - t'_{\beta}) \leq 2(m-1), \quad \text{for all } \mathbf{p} \in \mathbf{D}^{\text{type 2}} \setminus \mathbf{q}.$$

Hence (7.3) and (7.4) together imply

$$\mathbf{s} - \mathbf{t}^{\mathbf{s}'} \in S(\mathbf{D}, (m-1)\omega_3).$$

Case 3: In this case we suppose $\sum_{\beta} t'_{\beta} = 1$. The proof proceeds similarly to the proof of Case 2 and will be omitted.

Case 4: In this case we suppose that $\sum_{\beta} t'_{\beta} = 2$.

Here we have again two cases, namely either there exists $3 \leq j_3 < j_1 \leq 2n-4$ such that $t'_{1,j_1} = t'_{3,j_3} = 1$ or there exists $3 \leq j_3 < j_2 \leq 2n-4$ such that $t'_{2,j_2} = t'_{3,j_3} = 1$. The latter case works similarly and will be omitted.

Case 4.1: Suppose there exists $3 \leq j_3 < j_1 \leq 2n-4$ such that $t'_{1,j_1} = t'_{3,j_3} = 1$.

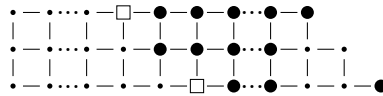

This case can be divided again into two further cases. One case treats $\sum_{k=3}^{2n-4} s_{1,k} = m$ and the other case $\sum_{k=3}^{2n-4} s_{1,k} \leq m-1$. In the latter case we can construct a multi-exponent $\mathbf{t} \in S(\mathbf{D}, \omega_3)$ similarly as in Case 2 such that $\mathbf{s} - \mathbf{t} \in S(\mathbf{D}, (m-1)\omega_3)$. The details will be omitted.

Case 4.1.1: We suppose that $\sum_{k=3}^{2n-4} s_{1,k} = m$. If $s_{2,2n-3} = 0$, we set $\mathbf{t} \in \mathbf{T}(1)$ to be the multi-exponent with $\text{supp}(\mathbf{t}) = \{\alpha_{3,j_3}, \alpha_{1,j_1}\}$. Then the statement can be easily deduced. So suppose from now on that $s_{2,2n-3} \neq 0$. This forces also that $s_{1,3} \neq 0$, because otherwise

$$\sum_{k=4}^{2n-4} s_{1,k} + s_{2,2n-3} = m + s_{2,2n-3} > m.$$

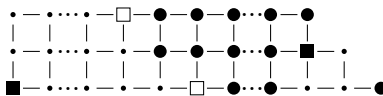

If in addition $s_{1,2n-2} = 0$, then we can define $\mathbf{t} \in \mathbf{T}(1)$ to be the multi-exponent with $\text{supp}(\mathbf{t}) = \{\alpha_{2,2n-3}, \alpha_{1,3}\}$ and the statement follows easily. So we can assume that $s_{1,2n-2}$ is also non-zero.

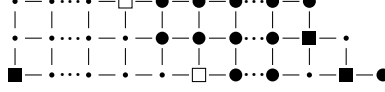

This is the only case where there is no multi-exponent $\mathbf{t} \in S(\mathbf{D}, \omega_3)$ such that $\mathbf{s} - \mathbf{t} \in S(\mathbf{D}, (m-1)\omega_3)$. We shall define a multi-exponent $\mathbf{t} \in S(\mathbf{D}, 2\omega_3)$ such that $\mathbf{s} - \mathbf{t} \in S(\mathbf{D}, (m-2)\omega_3)$. Let \mathbf{t} be the multi-exponent with $\text{supp}(\mathbf{t}) = \{\alpha_{3,j_3}, \alpha_{1,j_1}, \alpha_{1,3}, \alpha_{1,2n-2}, \alpha_{2,2n-3}\}$. Obviously we have $\mathbf{t} \in S(\mathbf{D}, 2\omega_3)$. If $\mathbf{p} \in \mathbf{D}_1^{\text{type } 1}$, then we can also deduce immediately

$$\sum_{\beta \in \mathbf{p}} (s_\beta - t_\beta) \leq m - 2.$$

So let $\mathbf{p} \in \mathbf{D}_2^{\text{type } 1}$. There is only something to prove if \mathbf{p} is of the following form

$$\mathbf{p} = \{\alpha_{1,4}, \dots, \alpha_{1,p}, \alpha_{2,p}, \dots, \alpha_{2,2n-3}, \alpha_{3,2n-3}\}, \text{ for some } p \leq j_3.$$

Since

$$s_{1,3} + \dots + s_{1,p} + s_{2,p} + \dots + s_{2,j_3} \leq m - s_{3,j_3} \leq m - 1 < \sum_{k=3}^{2n-4} s_{1,k}$$

we obtain by subtracting $s_{1,3}$ on both sides

$$s_{1,4} + \dots + s_{1,p} + s_{2,p} + \dots + s_{2,j_3} < s_{1,4} + \dots + s_{1,2n-4}.$$

Therefore

$$\sum_{\beta \in \mathbf{p}} (s_\beta - t_\beta) \leq \sum_{k=4}^{2n-3} (s_{1,k} - t_{1,k}) + (s_{2,2n-3} - t_{2,2n-3}) = \sum_{k=4}^{2n-3} s_{1,k} + s_{2,2n-3} - 2 \leq m - 2.$$

Let $\mathbf{p} = \mathbf{p}_1 \cup \mathbf{p}_2 \in \mathbf{D}^{\text{type } 2}$ be a type 2 Dyck path. There is only something to show if \mathbf{p}_1 is of the form

$$\mathbf{p}_1 = \{\alpha_{1,3}, \dots, \alpha_{1,p}, \alpha_{2,p}, \dots, \alpha_{2,2n-2}\}, \text{ for some where } p \leq j_3.$$

We get similar as above

$$\sum_{\beta \in \mathbf{p}} (s_\beta - t_\beta) \leq \sum_{k=3}^{2n-3} (s_{1,k} - t_{1,k}) + (s_{2,2n-3} - t_{2,2n-3}) + (s_{2,2n-2} - t_{2,2n-2}) + \sum_{\beta \in \mathbf{p}_2} (s_\beta - t_\beta) \leq 2(m-2).$$

7.3. We used the program Eclipse and the following code:

```

public class B3{
static int dim = 0;
public static void main(String[] args){
int m1, m2, m3 = 0;
for(m1 = 0; m1 <= 9; m1++){
for(m2 = 0; m2 <= 9; m2++){
for(m3 = 0; m3 <= 9; m3++){
if(m1 + m2 + m3 <= 9){
int s1, s2, s3, s4, s5, s6, s7, s8, s9 = 0;
for(s9 = 0; s9 <= m1; s9++){
for(s8 = 0; s8 <= m3; s8++){
for(s7 = 0; s7 <= m2; s7++){
    
```

- [9] Evgeny Feigin. \mathbb{G}_a^M degeneration of flag varieties. *Selecta Math. (N.S.)*, 18(3):513–537, 2012.
- [10] Evgeny Feigin and Michael Finkelberg. Degenerate flag varieties of type A: Frobenius splitting and BW theorem. *Math. Z.*, 275(1-2):55–77, 2013.
- [11] Evgeny Feigin, Michael Finkelberg, and Peter Littelmann. Symplectic degenerate flag varieties. *Canad. J. Math.*, 66(6):1250–1286, 2014.
- [12] Evgeny Feigin, Ghislain Fourier, and Peter Littelmann. Favourable modules: Filtrations, polytopes, Newton-Okounkov bodies and flat degeneration. arXiv:1306.1292v3.
- [13] Evgeny Feigin, Ghislain Fourier, and Peter Littelmann. PBW filtration and bases for irreducible modules in type A_n . *Transform. Groups*, 16(1):71–89, 2011.
- [14] Evgeny Feigin, Ghislain Fourier, and Peter Littelmann. PBW filtration and bases for symplectic Lie algebras. *Int. Math. Res. Not. IMRN*, (24):5760–5784, 2011.
- [15] Ghislain Fourier. PBW-degenerated Demazure modules and Schubert varieties for triangular elements. arXiv:1408.6939.
- [16] A. Gornitsky. Essential signatures and canonical bases in irreducible representations of the group G_2 . Diploma thesis, 2011, 2011.
- [17] Giovanni Cerulli Irelli and Martina Lanini. Degenerate flag varieties of type A and C are Schubert varieties. arXiv: 1403.2889, *Int. Math. Res. Notices* (to appear).
- [18] Victor G. Kac. *Infinite-dimensional Lie algebras*. Cambridge University Press, Cambridge, third edition, 1990.
- [19] Deniz Kus. Kirillov-Reshetikhin crystals, energy function and the combinatorial R-matrix. arXiv:1309.6522.
- [20] Deniz Kus. Realization of affine type A Kirillov-Reshetikhin crystals via polytopes. *J. Combin. Theory Ser. A*, 120(8):2093–2117, 2013.

TEODOR BACKHAUS:

MATHEMATISCHES INSTITUT, UNIVERSITÄT ZU KÖLN, GERMANY

E-mail address: tbackha@math.uni-koeln.de

DENIZ KUS:

MATHEMATISCHES INSTITUT, UNIVERSITÄT ZU KÖLN, GERMANY

E-mail address: dkus@math.uni-koeln.de

5. DEGREE CONES AND MONOMIAL BASES OF LIE ALGEBRAS AND QUANTUM GROUPS

TEODOR BACKHAUS, XIN FANG, GHISLAIN FOURIER

ABSTRACT. We extend the framework of the PBW filtration to quantum groups and provide case independent constructions, such as giving a filtration on the negative part of the quantum group, such that the associated graded algebra becomes a q -commutative polynomial algebra. By taking the classical limit we obtain, in some cases new, monomial bases and monomial ideals of the associated graded modules.

1. GENERAL REMARKS

1.1. On the monomiality. The reason why we are interested in the monomiality of the defining ideal: let I be a monomial ideal of the polynomial algebra $\mathbb{C}[x_1, x_2, \dots, x_n]$ such that the quotient $M := \mathbb{C}[x_1, x_2, \dots, x_n]/I$ is a finite dimensional vector space. The following property is important: M admits a *unique* monomial basis

$$\mathcal{B}(M) := \{\mathbf{x}^\alpha := x_1^{\alpha_1} x_2^{\alpha_2} \cdots x_n^{\alpha_n} \mid \mathbf{x}^\alpha \notin I\}.$$

2. LIE ALGEBRAS AND THE CLASSICAL DEGREE CONE

2.1. Notations and basic properties. Let \mathfrak{g} be a simple Lie algebra of rank n over \mathbb{C} . We fix a Cartan decomposition $\mathfrak{g} = \mathfrak{n}^+ \oplus \mathfrak{h} \oplus \mathfrak{n}^-$ and a set of simple roots $\Pi = \{\alpha_1, \dots, \alpha_n\}$ of \mathfrak{g} . The positive roots of \mathfrak{g} will be denoted by Δ_+ , whose cardinality will be denoted by N . For $\alpha \in \Delta_+$, we pick a root vector f_α of weight $-\alpha$. Let ϖ_i , $i = 1, \dots, n$ be the fundamental weights, \mathcal{P} be the weight lattice and $\mathcal{P}_+ = \sum_{i=1}^n \mathbb{N}\varpi_i$ be the set of dominant integral weights. For a dominant integral weight $\lambda \in \mathcal{P}_+$, let $V(\lambda)$ be the finite dimensional irreducible representation of \mathfrak{g} with highest weight λ and v_λ a highest weight vector. Let $U(\mathfrak{n}^-)$ be the universal enveloping algebra of \mathfrak{n}^- .

Let W be the Weyl group of \mathfrak{g} with generators s_1, \dots, s_n and $w_0 \in W$ be the longest element. We denote $R(w_0)$ the set of all reduced decompositions of w_0 .

For any reduced decomposition $\underline{w}_0 = s_{i_1} \dots s_{i_N} \in R(w_0)$ we associate a convex total order on Δ_+ : for $1 \leq t \leq N$, we denote $\beta_t = s_{i_1} \dots s_{i_{t-1}}(\alpha_{i_t})$, then $\Delta_+ = \{\beta_t \mid t = 1, \dots, N\}$ and $\beta_1 < \beta_2 < \dots < \beta_N$ is the desired convex total order, i.e. if $\beta_i < \beta_j$ and $\beta_i + \beta_j \in \Delta_+$, then

$$\beta_i < \beta_i + \beta_j < \beta_j.$$

It is proved in [P94] that the above association induces a bijection between $R(w_0)$ and the set of all convex total orders on Δ_+ .

2.2. The classical degree cone.

Definition 1. We define the following set

$$\mathcal{D} := \{(d_\beta)_{\beta \in \Delta_+} \in \mathbb{R}_+^N \mid \text{if } \alpha + \beta = \gamma \text{ for } \alpha, \beta, \gamma \in \Delta_+, \text{ then } d_\alpha + d_\beta > d_\gamma\}.$$

Since \mathcal{D} satisfies for all $x, y \in \mathcal{D}, \lambda_1, \lambda_2 \in \mathbb{R}_+ \setminus \{0\}$: $\lambda_1 x + \lambda_2 y \in \mathcal{D}$ we will call the set \mathcal{D} the *classical degree cone*.

We let $S(\mathcal{D}) := \mathcal{D} \cap \mathbb{N}^N$ denote the set of lattice points in \mathcal{D} . For any $\mathbf{d} = (d_\beta)_{\beta \in \Delta_+} \in S(\mathcal{D})$, we define a filtration $\mathcal{F}^{\mathbf{d}}$ on $U(\mathfrak{n}^-)$ by:

$$\mathcal{F}_s^{\mathbf{d}} := \text{span}\{f_{\beta_1} f_{\beta_2} \cdots f_{\beta_k} \in U(\mathfrak{n}^-) \mid \beta_1, \dots, \beta_k \in \Delta_+ \text{ such that } d_{\beta_1} + d_{\beta_2} + \cdots + d_{\beta_k} \leq s\}.$$

By the cyclicity, all irreducible representations $V(\lambda)$ admit a filtration arising from $\mathcal{F}^{\mathbf{d}}$:

$$\mathcal{F}_s^{\mathbf{d}} V(\lambda) := \mathcal{F}_s^{\mathbf{d}} \cdot v_\lambda.$$

The following lemma is immediate.

Lemma 1. *For any $\mathbf{d} \in S(\mathcal{D})$, we have:*

- (1) $\mathcal{F}^{\mathbf{d}} := (\mathcal{F}_0^{\mathbf{d}} \subset \mathcal{F}_1^{\mathbf{d}} \subset \cdots \subset \mathcal{F}_n^{\mathbf{d}} \subset \cdots)$ defines a filtration on $U(\mathfrak{n}^-)$ whose associated graded algebra is isomorphic to the symmetric algebra $S(\mathfrak{n}^-)$.
- (2) Let $V^{\mathbf{d}}(\lambda)$ be the graded module associated to the induced filtration. Then $V^{\mathbf{d}}(\lambda)$ is a cyclic $S(\mathfrak{n}^-)$ -module.

Let $v_\lambda^{\mathbf{d}}$ be a cyclic vector in $V^{\mathbf{d}}(\lambda)$. By (2) of the lemma above, the $S(\mathfrak{n}^-)$ -module map

$$\varphi : S(\mathfrak{n}^-) \rightarrow V^{\mathbf{d}}(\lambda), \quad x \mapsto x \cdot v_\lambda^{\mathbf{d}}$$

is surjective. We denote $I^{\mathbf{d}}(\lambda) := \ker \varphi$ and call it the defining ideal of $V^{\mathbf{d}}(\lambda)$.

2.3. The local and global monomial set.

Definition 2. The *local monomial set* \mathcal{S}_{lm} is defined by:

$$\mathcal{S}_{\text{lm}} := \{\mathbf{d} = (d_\beta)_{\beta \in \Delta_+} \in S(\mathcal{D}) \mid \text{for any } i = 1, 2, \dots, n, I^{\mathbf{d}}(\varpi_i) \text{ is a monomial ideal}\}.$$

Definition 3. The *global monomial set* \mathcal{S}_{gm} is defined by:

$$\mathcal{S}_{\text{gm}} := \{\mathbf{d} = (d_\beta)_{\beta \in \Delta_+} \in S(\mathcal{D}) \mid \text{for any } \lambda \in \mathcal{P}_+, I^{\mathbf{d}}(\lambda) \text{ is a monomial ideal}\}.$$

It is clear that $\mathcal{S}_{\text{gm}} \subset \mathcal{S}_{\text{lm}}$.

The main goal of this paper is to study the following questions:

- (1) whether the global monomial set \mathcal{S}_{gm} is empty? That is to say, does there exist a filtration on $U(\mathfrak{n}^-)$ arising from a degree $\mathbf{d} \in \mathcal{D}$ such that for any finite-dimensional irreducible representation, its defining ideal is monomial?
- (2) if the answer to the above question is affirmative, is there a polytope such that its lattice points parametrize this basis? That is to say, for any $\lambda \in \mathcal{P}_+$, we want to find a polytope $P(\lambda)$ such that

$$\{f^{\mathbf{a}} v_\lambda^{\mathbf{d}} = \prod_{i=1}^n f_{\beta_i}^{a_i} v_\lambda^{\mathbf{d}} \mid \mathbf{a} \in P_{\mathbb{N}}(\lambda) := P(\lambda) \cap \mathbb{N}^N\}$$

is a monomial basis of $V^{\mathbf{d}}(\lambda)$?

Let $\mathbf{d} \in \mathcal{S}_{\text{lm}}$ and define $P_{\mathbb{N}}(\varpi_i) = \{\mathbf{a} \in \mathbb{N}^N \mid f^{\mathbf{a}} v_{\varpi_i}^{\mathbf{d}} \neq 0 \text{ in } V^{\mathbf{d}}(\varpi_i)\}$, for $1 \leq i \leq n$.

Theorem 1. *For any $\lambda = m_1 \varpi_1 + m_2 \varpi_2 + \cdots + m_n \varpi_n \in \mathcal{P}_+$, if $\#(m_1 P_{\mathbb{N}}(\varpi_1) + m_2 P_{\mathbb{N}}(\varpi_2) + \cdots + m_n P_{\mathbb{N}}(\varpi_n)) = \dim V(\lambda)$, then $\mathbf{d} \in \mathcal{S}_{\text{gm}}$.*

Note $+$ denotes the Minkowski sum and $m_i P_{\mathbb{N}}(\varpi_i)$ the m_i -th Minkowski sum of $P_{\mathbb{N}}(\varpi_i)$.

Proof. The assumption $\mathbf{d} \in \mathcal{S}_{\text{lm}}$ implies $I^{\mathbf{d}}(\varpi_i)$ is a monomial ideal and $P_{\mathbb{N}}(\varpi_i)$ parametrizes a unique monomial basis of $V^{\mathbf{d}}(\varpi_i)$ for all $1 \leq i \leq n$. This provides the induction start for an induction on the height of $\lambda \in \mathcal{P}_+$, $|\lambda| = \sum_{i=1}^n m_i$, where $\lambda = \sum_{i=1}^n m_i \varpi_i$. Since the proof is the same as in [FFR, Section 1.6] we just state the ideas, note that the steps are not trivial.

First we extend the partial order given by the degree $\deg f_{\beta_i} = d_i$ on Δ_+ to a total order on Δ_+ , for example by linearly ordering roots if the associated root vectors have the same degree.

For notational reasons we state the ideas only for fundamental weights ϖ_i, ϖ_j . Using the statement in [FFL3, Proposition 2.11] we obtain that for any $\varpi_i, \varpi_j \in \mathcal{P}_+$, the set

$$\{f^{\mathbf{a}}(v_{\varpi_i}^{\mathbf{d}} \otimes v_{\varpi_j}^{\mathbf{d}}) \mid \mathbf{a} \in P_{\mathbb{N}}(\varpi_i) + P_{\mathbb{N}}(\varpi_j)\} \subset V^{\mathbf{d}}(\varpi_i) \otimes V^{\mathbf{d}}(\varpi_j)$$

is linear independent and hence in $V(\varpi_i) \otimes V(\varpi_j)$. By dimension arguments, using the assumption $|P_{\mathbb{N}}(\varpi_i) + P_{\mathbb{N}}(\varpi_j)| = \dim V(\varpi_i + \varpi_j)$, we obtain a basis of the Cartan component $V(\varpi_i) \odot V(\varpi_j) = U(\mathfrak{n}^-)(v_{\varpi_i} \otimes v_{\varpi_j}) \subset V(\varpi_i) \otimes V(\varpi_j)$. Using this and induction we obtain $\{f^{\mathbf{a}}v_{\varpi_i+\varpi_j}^{\mathbf{d}} \mid \mathbf{a} \in P_{\mathbb{N}}(\varpi_i) + P_{\mathbb{N}}(\varpi_j)\}$ is a monomial basis of $V^{\mathbf{d}}(\varpi_i + \varpi_j)$. The last step is to show that the defining ideal of $V^{\mathbf{d}}(\varpi_i) \odot V^{\mathbf{d}}(\varpi_j) = S(\mathfrak{n}^-)(v_{\varpi_i}^{\mathbf{d}} \otimes v_{\varpi_j}^{\mathbf{d}})$ is monomial and there is a $S(\mathfrak{n}^-)$ -module isomorphism

$$V^{\mathbf{d}}(\varpi_i) \odot V^{\mathbf{d}}(\varpi_j) \rightarrow V^{\mathbf{d}}(\varpi_i + \varpi_j).$$

By applying this to arbitrary weights we conclude $\mathbf{d} \in \mathcal{S}_{\text{gm}}$. \square

This theorem is useful to prove that there exists $\mathbf{d} \in \mathcal{S}_{\text{gm}}$ in the case of \mathbf{A}_n and conjecturally \mathbf{C}_n such that the lattice points of the FFL polytopes (see [FFL1],[FFL2]) parametrize a monomial basis of $V^{\mathbf{d}}(\lambda)$. We get similar results in the cases of \mathbf{B}_3 , the polytope is described in [BK], and in type \mathbf{D}_4 and \mathbf{G}_2 , the polytopes are described in [Gor2] and [Gor1] respectively.

3. QUANTUM GROUPS AND QUANTUM DEGREE CONES

3.1. Quantum groups. In the following we state fundamental facts on quantum groups following [FFR]. Let \mathfrak{g} be a simple Lie algebra of rank n with Cartan matrix $C = (c_{ij}) \in \text{Mat}_n(\mathbb{Z})$. Let $D = \text{diag}(d_1, \dots, d_n) \in \text{Mat}_n(\mathbb{Z})$ be a diagonal matrix symmetrizing C , thus $A = DC = (a_{ij}) \in \text{Mat}_n(\mathbb{Z})$ is the symmetrized Cartan matrix. Let $U_q(\mathfrak{g})$ be the corresponding quantum group over $\mathbb{C}(q)$: as an algebra, it is generated by E_i, F_i and $K_i^{\pm 1}$ for $i = 1, \dots, n$, subject to the following relations: for $i, j = 1, \dots, n$,

$$K_i K_i^{-1} = K_i^{-1} K_i = 1, \quad K_i E_j K_i^{-1} = q_i^{c_{ij}} E_j, \quad K_i F_j K_i^{-1} = q_i^{-c_{ij}} F_j,$$

$$E_i F_j - F_j E_i = \delta_{ij} \frac{K_i - K_i^{-1}}{q_i - q_i^{-1}},$$

and for $i \neq j$,

$$\sum_{r=0}^{1-c_{ij}} (-1)^r E_i^{(1-c_{ij}-r)} E_j E_i^{(r)} = 0, \quad \sum_{r=0}^{1-c_{ij}} (-1)^r F_i^{(1-c_{ij}-r)} F_j F_i^{(r)} = 0,$$

where

$$q_i = q^{d_i}, \quad [n]_q! = \prod_{i=1}^n \frac{q^n - q^{-n}}{q - q^{-1}}, \quad E_i^{(n)} = \frac{E_i^n}{[n]_{q_i}!} \quad \text{and} \quad F_i^{(n)} = \frac{F_i^n}{[n]_{q_i}!}.$$

Let $U_q(\mathfrak{n}^-)$ be the subalgebra of $U_q(\mathfrak{g})$ generated by F_i for $i = 1, \dots, n$. For $\lambda \in \mathcal{P}_+$, we denote by $V_q(\lambda)$ the irreducible representation of $U_q(\mathfrak{g})$ of highest weight λ and type 1 with highest weight vector \mathbf{v}_λ .

When q is specialized to 1, the quantum group $U_q(\mathfrak{g})$ admits $U(\mathfrak{g})$ as its classical limit. In this limit, the representation $V_q(\lambda)$ is specialized to $V(\lambda)$.

3.2. PBW root vectors and commutation relations. Let $T_i = T''_{i,1}$, $i = 1, \dots, n$ be Lusztig's automorphisms:

$$T_i(E_i) = -F_i K_i, \quad T_i(F_i) = -K_i^{-1} E_i, \quad T_i(K_j) = K_j K_i^{-c_{ij}},$$

for $i = 1, \dots, n$, and for $j \neq i$,

$$T_i(E_j) = \sum_{r+s=-c_{ij}} (-1)^r q_i^{-r} E_i^{(s)} E_j E_i^{(r)}, \quad T_i(F_j) = \sum_{r+s=-c_{ij}} (-1)^r q_i^r F_i^{(r)} F_j F_i^{(s)}.$$

We refer to Chapter 37 in [Lus] for details. We fix a reduced decomposition $w_0 = s_{i_1} s_{i_2} \dots s_{i_N} \in R(w_0)$ and let positive roots $\beta_1, \beta_2, \dots, \beta_N$ be as defined in Section 2.1. The quantum PBW root vector F_{β_t} associated to a positive root β_t is defined by:

$$F_{\beta_t} = T_{i_1} T_{i_2} \dots T_{i_{t-1}}(F_{i_t}) \in U_q(\mathfrak{n}^-).$$

The PBW theorem of quantum groups affirms that the set

$$\{F^{\mathbf{c}} := F_{\beta_1}^{c_1} F_{\beta_2}^{c_2} \dots F_{\beta_N}^{c_N} \mid \mathbf{c} = (c_1, \dots, c_N) \in \mathbb{N}^N\}$$

forms a $\mathbb{C}(q)$ -basis of $U_q(\mathfrak{n}^-)$ ([Lus, Corollary 40.2.2]).

The commutation relation between these quantum PBW root vectors is given by the following Levendorskiĭ-Soibelman (L-S for short, see [LS91]) formula: for any $i < j$,

$$F_{\beta_j} F_{\beta_i} - q^{-(\beta_i, \beta_j)} F_{\beta_i} F_{\beta_j} = \sum_{n_{i+1}, \dots, n_{j-1} \geq 0} c(n_{i+1}, \dots, n_{j-1}) F_{\beta_{i+1}}^{n_{i+1}} \dots F_{\beta_{j-1}}^{n_{j-1}}, \quad (3.1)$$

where $c(n_{i+1}, \dots, n_{j-1}) \in \mathbb{C}[q^{\pm 1}]$. We denote

$$M_{i,j} = \{F_{\beta_{i+1}}^{n_{i+1}} F_{\beta_{i+2}}^{n_{i+2}} \dots F_{\beta_{j-1}}^{n_{j-1}} \mid n_{i+1}\beta_{i+1} + n_{i+2}\beta_2 + \dots + n_{j-1}\beta_{j-1} = \beta_i + \beta_j\},$$

then for weight reasons, the sum in the right-hand side of the L-S formula (3.1) is supported in $M_{i,j}$. Denote by $M_{i,j}^q$ the set of monomials which actually appear with a non-zero coefficient in the right-hand side of (3.1). It should be pointed out that the right-hand side in the L-S formula largely depends on the chosen reduced decomposition. In general it is hard to know which monomials appear in the right-hand side.

Let us have a closer look on how these formulas depend on the reduced decomposition. Let $\underline{w}_0, \underline{w}'_0 \in R(w_0)$ be two reduced decompositions such that they are of form

$$\underline{w}_0 = \underline{w}_L s_p s_q \underline{w}_R, \quad \underline{w}'_0 = \underline{w}_L s_q s_p \underline{w}_R$$

with $1 \leq p \neq q \leq n$ and $s_p s_q = s_q s_p$. We define $l = \ell(\underline{w}_L)$.

Let the convex total order on Δ_+ induced by \underline{w}_0 (resp. \underline{w}'_0) be:

$$\beta_1 < \beta_2 < \dots < \beta_N \quad (\text{resp. } \beta'_1 < \beta'_2 < \dots < \beta'_N).$$

For $s \leq l$, the L-S formula (3.1) reads:

$$F_{\beta_s} F_{\beta_{l+2}} - q^{(\beta_s, \beta_{l+2})} F_{\beta_{l+2}} F_{\beta_s} = \sum_{n_{s+1}, \dots, n_{l+1} \geq 0} c(n_{s+1}, \dots, n_{l+1}) F_{\beta_{s+1}}^{n_{s+1}} \dots F_{\beta_{l+1}}^{n_{l+1}}. \quad (3.2)$$

For $t \geq l+3$, the L-S formula (3.1) reads:

$$F_{\beta_t} F_{\beta_{l+1}} - q^{-(\beta_t, \beta_{l+1})} F_{\beta_{l+1}} F_{\beta_t} = \sum_{n_{l+2}, \dots, n_{t-1} \geq 0} c(n_{l+2}, \dots, n_{t-1}) F_{\beta_{l+2}}^{n_{l+2}} \dots F_{\beta_{t-1}}^{n_{t-1}}. \quad (3.3)$$

Lemma 2. *In the formula (3.2), $n_{l+1} = 0$; in the formula (3.3), $n_{l+2} = 0$.*

Proof. We prove for example the first statement, the second one can be shown similarly.

First notice that for any $i \neq l+1, l+2$, $\beta_i = \beta'_i$, $\beta_{l+1} = \beta'_{l+2}$, $\beta_{l+2} = \beta'_{l+1}$. The same argument can be applied to quantum PBW root vectors: let $F_{\beta_1}, F_{\beta_2}, \dots, F_{\beta_N}$ (resp. $F'_{\beta_1}, F'_{\beta_2}, \dots, F'_{\beta_N}$) be the quantum PBW root vectors obtained from \underline{w}_0 (resp. \underline{w}'_0). Then for any $i \neq l+1, l+2$, $F_{\beta_i} = F'_{\beta_i}$, $F_{\beta_{l+1}} = F'_{\beta_{l+2}}$, $F_{\beta_{l+2}} = F'_{\beta_{l+1}}$. For $s \leq l$, we apply the L-S formula to F'_{β_s} and $F'_{\beta_{l+1}}$, it gives:

$$F'_{\beta_s} F'_{\beta_{l+1}} - q^{(\beta'_s, \beta'_{l+1})} F'_{\beta_{l+1}} F'_{\beta_s} = \sum_{m_{s+1}, \dots, m_l \geq 0} d(m_{s+1}, \dots, m_l) F_{\beta_{s+1}}^{m_{s+1}} \dots F_{\beta_l}^{m_l}.$$

Compare it to (3.3) gives $n_{l+1} = 0$. □

3.3. Quantum degree cones.

Definition 4. For a reduced decomposition $\underline{w}_0 \in R(w_0)$, we define the *quantum degree cone* $\mathcal{D}_{\underline{w}_0}^q$ associated to it by:

$$\mathcal{D}_{\underline{w}_0}^q := \{(d_\beta) \in \mathbb{R}_+^N \mid \text{for any } i < j, d_{\beta_i} + d_{\beta_j} > \sum_{k=i+1}^{j-1} n_k d_{\beta_k} \text{ if } c(n_{i+1}, \dots, n_{j-1}) \neq 0 \text{ in (3.1)}\}.$$

Remark 1. As in the definition of the classical degree cone, the notion of quantum degree cone is motivated by the fact that $\mathcal{D}_{\underline{w}_0}^q$ is closed under summation and non-zero scalar multiplication.

We denote the set

$$\mathcal{D}^q := \bigcup_{\underline{w}_0 \in R(w_0)} \mathcal{D}_{\underline{w}_0}^q.$$

Theorem 2. For any $\underline{w}_0 \in R(w_0)$, the set $\mathcal{D}_{\underline{w}_0}^q$ is non-empty.

Proof. Let $\mathbf{x} = (x_1, x_2, \dots, x_N)$ be a N-tuple of variables, we shall describe an inductive procedure how to construct an element of $\mathcal{D}_{\underline{w}_0}^q$, i.e. how to set the values of $x_i, 1 \leq i \leq N$, such that $\mathbf{x} \in \mathcal{D}_{\underline{w}_0}^q$. Denote d_{β_i} by $d_i, 1 \leq i \leq n$.

We set $\deg F_{\beta_i} = 1$ for all $1 \leq i \leq n$ and the first two steps are setting $x_1, x_2 = 1$, note that $M_{1,2}^q = \emptyset$.

We consider the variable $x_3, M_{1,3}^q$ is not empty in general and we set

$$x_3 = \max\{1, \deg(m) \mid m \in M_{1,3}^q\}.$$

Either $M_{1,3}^q = \emptyset$, then there is no inequality and we set $x_3 = 1$ or there exists $m = F_{\beta_2}^{n_2} \in M_{1,3}^q$, with $n_2 \beta_2 = \beta_1 + \beta_3, n_2 \geq 1$ and we have exactly one inequality:

$$d_1 + d_3 > \deg(m).$$

In this case we set $x_3 = \deg(m)$, which is $n_2 x_2 = n_2$. Then the above inequality is satisfied: $x_1 + x_3 = 1 + \deg(m) > \deg(m)$. We set $\deg F_{\beta_3} = x_3$.

Note up this point this choice is minimal regarding the sum $x_1 + x_2 + x_3$ and lexicographical minimal regarding the convex order under the assumption $x_1 = 1$. This is not important for the proof, but as a side effect we shall be interested in the latter minimality.

In the fourth step we consider all possible inequalities implying restrictions for x_1, x_2, x_4 :

$$\begin{aligned} d_1 + d_4 &> \deg(m), \quad m \in M_{1,4}^q \\ d_2 + d_4 &> \deg(m), \quad m \in M_{2,4}^q. \end{aligned} \tag{3.4}$$

Together with those in the step before these are all inequalities defining $\mathcal{D}_{\underline{w}_0}^q$ containing only d_1, d_2, d_3 and d_4 . We set

$$x_4 = \max\{1, \deg(m) \mid m \in M_{1,4}^q, m \in M_{2,4}^q\}.$$

Since we have a finite number of monomials of the fixed weights $\beta_1 + \beta_4$ and $\beta_2 + \beta_4$ this maximum exists and (3.4) is satisfied. We set $\deg F_{\beta_4} = x_4$. We do not change $\deg F_{\beta_1}, \deg F_{\beta_2}$ and $\deg F_{\beta_3}$ in this step. This means, the inequalities from the steps before are still satisfied. This implies that the new \mathbf{x} satisfies all inequalities defining $\mathcal{D}_{\underline{w}_0}^q$ containing only d_1, d_2, d_3 and d_4 .

In the k -th step we have the following inequalities:

$$d_j + d_k > \deg(m), \quad m \in M_{j,k}^q, \quad \text{for all } 1 \leq j \leq k-2. \quad (3.5)$$

Again we have a finite number of inequalities and it is possible to set x_k as the maximum of the right-hand sides. Since we want to construct the lexicographic minimal solution satisfying $x_1 = 1$, regarding the order $\beta_1 < \dots < \beta_N$, we set

$$\deg(m)' := \deg(m) - x_j + 1, \quad \text{for } m \in M_{j,k}^q,$$

for all $1 \leq j \leq k-2$ and set

$$x_k = \max\{1, \deg(m)' \mid m \in M_{j,k}^q, 1 \leq j \leq k-2\}.$$

By construction \mathbf{x} satisfies the inequalities in (3.5). We set $\deg F_{\beta_k} = x_k$. Since x_1, x_2, \dots, x_{k-1} satisfy the inequalities of the $k-1$ steps before and we only change $\deg F_{\beta_k}$ in this step, the choice of x_1, \dots, x_k satisfies all inequalities defining $\mathcal{D}_{\underline{w}_0}^q$ containing only d_1, d_2, \dots, d_k . After N steps we have constructed an element $(x_1, \dots, x_N) \in \mathcal{D}_{\underline{w}_0}^q$. \square

From now on we fix a reduced decomposition $\underline{w}_0 \in R(w_0)$. Let $\mathbf{d} \in S(\mathcal{D}_{\underline{w}_0}^q) = \mathcal{D}_{\underline{w}_0}^q \cap \mathbb{N}^N$. For a monomial $F^{\mathbf{t}} = F_{\beta_1}^{t_1} F_{\beta_2}^{t_2} \dots F_{\beta_N}^{t_N} \in U_q(\mathfrak{n}^-)$, we define its \mathbf{d} -degree $\deg_{\mathbf{d}}$ by:

$$\deg_{\mathbf{d}}(F^{\mathbf{t}}) = t_1 d_{\beta_1} + t_2 d_{\beta_2} + \dots + t_N d_{\beta_N}.$$

Then we can define a filtration $\mathcal{F}_{\bullet}^{\mathbf{d}} = (\mathcal{F}_0^{\mathbf{d}} \subset \mathcal{F}_1^{\mathbf{d}} \subset \dots \subset \mathcal{F}_{\mathbf{n}}^{\mathbf{d}} \subset \dots)$ on $U_q(\mathfrak{n}^-)$ by:

$$\mathcal{F}_{\mathbf{k}}^{\mathbf{d}} := \text{span}\{F^{\mathbf{t}} \in U_q(\mathfrak{n}^-) \mid \deg_{\mathbf{d}}(F^{\mathbf{t}}) \leq \mathbf{k}\}.$$

Let $S_q(\mathfrak{n}^-)$ be the algebra generated by x_1, x_2, \dots, x_N , subject to the following relations: for $1 \leq i < j \leq N$,

$$x_i x_j = q^{(\beta_i, \beta_j)} x_j x_i.$$

The following proposition is clear from the L-S formula (3.1).

Proposition 1. (1) The filtration $\mathcal{F}_{\bullet}^{\mathbf{d}}$ endows $U_q(\mathfrak{n}^-)$ with a filtered algebra structure.
 (2) The associated graded algebra $\text{gr}^{\mathbf{d}} U_q(\mathfrak{n}^-)$ is a q -commutative polynomial algebra isomorphic to $S_q(\mathfrak{n}^-)$.

For $\lambda \in \mathcal{P}_+$, the above filtration on $U_q(\mathfrak{n}^-)$ induces a filtration on $V_q(\lambda)$ by letting

$$\mathcal{F}_{\mathbf{k}}^{\mathbf{d}} V_q(\lambda) := \mathcal{F}_{\mathbf{k}}^{\mathbf{d}} \cdot \mathbf{v}_{\lambda}.$$

We let $V_q^{\mathbf{d}}(\lambda)$ denote the associated graded vector space: it is a cyclic $S_q(\mathfrak{n}^-)$ -module. Let $\mathbf{v}_{\lambda}^{\mathbf{d}}$ be a cyclic vector and $I_q^{\mathbf{d}}(\lambda)$ be the defining ideal defined as before.

When the quantum parameter q is specialized to 1, the L-S formula is specialized to:

$$f_{\beta_i} f_{\beta_j} - f_{\beta_j} f_{\beta_i} = \begin{cases} c_{i,j}^k f_{\beta_k}, & \text{if } \beta_i + \beta_j = \beta_k; \\ 0, & \text{otherwise.} \end{cases}$$

This proves the following lemma.

Lemma 3. We have $\mathcal{D}^q \subset \mathcal{D}$.

Remark 2. Except for small rank cases $\mathfrak{g} = \mathfrak{sl}_2, \mathfrak{sl}_3$ (see Subsection 4.1.1), the inclusion in Lemma 3 is strict. For example, the element $\mathbf{1} = (1, 1, \dots, 1)$ is in the classical degree cone \mathcal{D} , but for $\mathfrak{g} \neq \mathfrak{sl}_2, \mathfrak{sl}_3$, we can always find a reduced decomposition \underline{w}_0 such that $\mathbf{1} \notin \mathcal{D}_{\underline{w}_0}^q$. See for example [FFR, Section 2.4] and Subsections 4.1.2 for type \mathbf{C}_2 and 4.1.3 for type \mathbf{G}_2 respectively.

4. EXAMPLES AND PROPERTIES OF QUANTUM DEGREE CONES

4.1. Examples of rank 2.

4.1.1. \mathbf{A}_2 . For the Lie algebra \mathfrak{sl}_2 neither in the classical degree nor in the quantum degree cone exist relations, since we have only one (quantum) PBW root vector f_1 (resp. F_1).

So let $\mathfrak{g} = \mathfrak{sl}_3$ be the Lie algebra of type \mathbf{A}_2 . The classical degree cone \mathcal{D} is given by the following inequalities: $\mathbf{d} = (d_1, d_{12}, d_2) \in \mathbb{R}_+^3$ where d_{12} correspond to the degree of f_{12} .

$$d_1 + d_2 > d_{12}.$$

Fix a reduced decomposition $\underline{w}_0 = s_1 s_2 s_1$ of the longest element w_0 in the Weyl group of \mathfrak{g} . Let

$$F_1, F_{12}, F_2$$

be the quantum PBW root vectors, their commutation relations are:

$$F_1 F_2 = q^{-1} F_2 F_1 - q^{-1} F_{12}.$$

The quantum degree cone $\mathcal{D}_{\underline{w}_0}^q \subset \mathcal{D}$ is given by:

$$d_1 + d_2 > d_{12}$$

and we obtain $\mathcal{D}_{\underline{w}_0}^q = \mathcal{D}$. The same construction with the reduced decomposition $\underline{w}_0^1 = s_2 s_1 s_2$ shows that $\mathcal{D}_{\underline{w}_0}^q = \mathcal{D}_{\underline{w}_0^1}^q$.

Remark 3. Here we would like to emphasize, whenever we compare cones, the α component of any cone has to match the α component of each other cone.

4.1.2. \mathbf{C}_2 . Let $\mathfrak{g} = \mathfrak{sp}_4$ be the Lie algebra of type \mathbf{C}_2 . The classical degree cone \mathcal{D} is given by the following inequalities: $\mathbf{d} = (d_1, d_{112}, d_{12}, d_2) \in \mathbb{R}_+^4$ where d_{12} (resp. d_{112}) correspond to the degree of f_{12} (resp. f_{112}):

$$d_1 + d_2 > d_{12}, \quad d_1 + d_{12} > d_{112}.$$

Fix a reduced decomposition $\underline{w}_0 = s_1 s_2 s_1 s_2$ of the longest element w_0 in the Weyl group of \mathfrak{g} . Let

$$F_1, F_{112}, F_{12}, F_2$$

be the corresponding quantum PBW root vectors, their commutation relations are:

$$F_1 F_{112} = q^2 F_{112} F_1, \quad F_1 F_{12} = F_{12} F_1 - (q + q^{-1}) F_{112}, \quad F_1 F_2 = q^{-2} F_2 F_1 - q^{-2} F_{12},$$

$$F_{112} F_{12} = q^2 F_{12} F_{112}, \quad F_{112} F_2 = F_2 F_{112} + (1 - q^{-2}) F_{12}^{(2)}, \quad F_{12} F_2 = q^2 F_2 F_{12}.$$

The quantum degree cone $\mathcal{D}_{\underline{w}_0}^q \subset \mathcal{D}$ is given by:

$$d_1 + d_2 > d_{12}, \quad d_1 + d_{12} > d_{112}, \quad d_{12} + d_{112} > 2d_{12}. \quad (4.1)$$

The same construction with the reduced decomposition $\underline{w}_0^1 = s_2 s_1 s_2 s_1$ shows that $\mathcal{D}_{\underline{w}_0}^q = \mathcal{D}_{\underline{w}_0^1}^q$.

4.1.3. \mathfrak{G}_2 . Let \mathfrak{g} be the Lie algebra of type \mathfrak{G}_2 . The classical degree cone \mathcal{D} is given by the following inequalities: $\mathbf{d} = (d_1, d_{1112}, d_{112}, d_{11122}, d_{12}, d_2) \in \mathbb{R}_+^6$:

$$\begin{aligned} d_1 + d_2 &> d_{12}, & d_1 + d_{12} &> d_{112}, & d_1 + d_{112} &> d_{1112}, \\ d_2 + d_{1112} &> d_{11122}, & d_{112} + d_{12} &> d_{11122}. \end{aligned}$$

For example $(2, 1, 3, 1, 3, 2) \in \mathcal{D}$. We will use this special element later (see Subsection 5.4.3)

We fix a reduced decomposition $\underline{w}_0 = s_1 s_2 s_1 s_2 s_1 s_2 \in R(w_0)$. Let

$$F_1, F_{1112}, F_{112}, F_{11122}, F_{12}, F_2$$

be the corresponding quantum PBW root vectors, their commutation relations are:

$$\begin{aligned} F_1 F_{1112} &= q^3 F_{1112} F_1, & F_1 F_{112} &= q F_{112} F_1 - (q^3 + q^{-1}) F_{1112}, & F_1 F_{11122} &= F_{11122} F_1 + (q - q^{-3}) F_{112}^{(2)}, \\ F_1 F_{12} &= q^{-1} F_{12} F_1 - (1 + q^{-2}) F_{112}, & F_1 F_2 &= q^{-3} F_2 F_1 - F_{12}, & F_{1112} F_{112} &= q^3 F_{112} F_{1112}, \\ F_{1112} F_{11122} &= q^3 F_{11122} F_{1112} - (q^3 - q - q^{-1} + q^{-3}) F_{112}^{(3)}, & F_{1112} F_{12} &= F_{12} F_{1112} + (q - q^{-3}) F_{112}^{(2)}, \\ F_{1112} F_2 &= q^{-3} F_2 F_{1112} + (-q^{-3} - q^{-5}) F_{112} F_{12} + (q^{-2} + q^{-4} - q^{-7}) F_{11122}, \\ F_{112} F_{11122} &= q^3 F_{11122} F_{112}, & F_{112} F_{12} &= q F_{12} F_{112} - (q^3 + q + q^{-1}) F_{11122}, \\ F_{112} F_2 &= F_2 F_{112} + (q - q^{-3}) F_{12}^{(2)}, & F_{11122} F_{12} &= q^3 F_{12} F_{11122}, \\ F_{11122} F_2 &= q^3 F_2 F_{11122} - (q^3 - q - q^{-1} + q^{-3}) F_{12}^{(3)}, & F_{12} F_2 &= q^3 F_2 F_{12}. \end{aligned}$$

The quantum degree cone $\mathcal{D}_{\underline{w}_0}^q \subset \mathcal{D}$ is given by:

$$\begin{aligned} d_1, d_{1112}, d_{112}, d_{11122}, d_{12}, d_2 &> 0, \\ d_1 + d_{112} &> d_{1112}, & d_1 + d_{11122} &> 2d_{112}, & d_1 + d_{12} &> d_{112}, & d_1 + d_2 &> d_{12}, \\ d_{1112} + d_{11122} &> 3d_{112}, & d_{1112} + d_{12} &> 2d_{112}, & d_{1112} + d_2 &> d_{112} + d_{12}, \\ d_{1112} + d_2 &> d_{11122}, & d_{112} + d_{12} &> d_{11122}, & d_{112} + d_2 &> 2d_{12}, & d_{11122} + d_2 &> 3d_{12}. \end{aligned} \tag{4.2}$$

Again, these inequalities do not depend on the choice of the reduced decomposition.

4.1.4. From the examples above we obtain:

Proposition 2. Let \mathfrak{g} be of type $\mathfrak{A}_1, \mathfrak{A}_2, \mathfrak{C}_2, \mathfrak{G}_2$. For any $\underline{w}_0 \in R(w_0)$, we have $\mathcal{D}^q = \mathcal{D}_{\underline{w}_0}^q$.

4.2. Examples of rank 3.

4.2.1. \mathfrak{C}_3 . Let \mathfrak{g} be of type \mathfrak{C}_3 and enote by $F_{i,\bar{j}}$ the quantum PBW root vector associated to the root $\alpha_i + \cdots + \alpha_{j-1} + 2\alpha_j + \cdots + 2\alpha_{n-1} + \alpha_n$ for $1 \leq i \leq j < n = 3$ and denote $F_{i,j}$ the quantum PBW root vector associated to the root $\alpha_i + \cdots + \alpha_j$ for $1 \leq i \leq j \leq n = 3$. We fix the reduced decomposition

$$\underline{w}_0 = (s_1 s_2 s_3 s_2 s_1)(s_2 s_3 s_2) s_3$$

of $w_0 \in W$. The quantum PBW root vectors are

$$F_{1,1}, F_{1,2}, F_{1,\bar{1}}, F_{1,3}, F_{1,\bar{2}}, F_{2,2}, F_{2,\bar{2}}, F_{2,3}, F_{3,3}.$$

These vectors generate $U_q(\mathfrak{n}^-)$, the commutation relations determine the cone $\mathcal{D}_{\underline{w}_0}^q$ as before. The defining inequalities are the following, d_i corresponds to the degree of the i -th (from left to right) quantum PBW root vector above:

$$\begin{aligned} d_1 + d_5 &> d_3, & d_1 + d_5 &> d_2 + d_4, & d_1 + d_6 &> d_2, & d_1 + d_7 &> d_5, & d_1 + d_7 &> d_4 + d_6, \\ d_1 + d_8 &> d_4, & d_2 + d_4 &> d_3, & d_2 + d_7 &> d_5 + d_6, & d_2 + d_7 &> d_4 + 2d_6, & d_2 + d_8 &> d_5, \\ d_2 + d_8 &> d_4 + d_6, & d_2 + d_9 &> d_4, & d_3 + d_7 &> 2d_5, & d_3 + d_7 &> d_4 + d_5 + d_6, \\ d_3 + d_7 &> 2d_4 + 2d_6, & d_3 + d_8 &> d_4 + d_5, & d_3 + d_8 &> 2d_4 + d_6, & d_3 + d_9 &> 2d_4, \end{aligned}$$

$$d_4 + d_6 > d_5, \quad d_6 + d_8 > d_7, \quad d_6 + d_9 > d_8, \quad d_7 + d_9 > 2d_8.$$

There are four elements in $D_{\underline{w}_0}^q$, which are minimal regarding the sum over all entries:

$$\begin{aligned} \mathbf{d}_1 &= (2, 1, 1, 1, 1, 1, 4, 4, 5), & \mathbf{d}_2 &= (3, 2, 2, 1, 1, 1, 3, 3, 4), \\ \mathbf{d}_3 &= (5, 4, 4, 1, 1, 1, 1, 1, 2), & \mathbf{d}_4 &= (4, 3, 3, 1, 1, 1, 2, 2, 3). \end{aligned}$$

Since $\mathbf{d}_1, \mathbf{d}_2, \mathbf{d}_3, \mathbf{d}_4 \in \mathcal{D}$ we go back to the classical case. We consider the fundamental module $V(\varpi_2)$ and the weight $\tau = 2\alpha_1 + 3\alpha_2 + \alpha_3$ whose weight space $V(\varpi_2)_{\varpi_2 - \tau}$ is of dimension 1. We have to choose an element with minimal degree from the following set, where we neglect the elements which have obviously a higher degree:

$$\{f_{1,2}f_{1,\bar{2}}, f_{1,\bar{1}}f_{2,2}\}.$$

For each of the above elements in $D_{\underline{w}_0}^q$ both monomials have the same degree, so we do not obtain a monomial ideal $I^{\mathbf{d}_i}$, $1 \leq i \leq 4$.

By taking larger degrees $\mathbf{d} \in D_{\underline{w}_0}^q$ it is possible to obtain a unique monomial basis of $V^{\mathbf{d}}(\varpi_2)$, where it is possible to obtain a basis with either of both monomials applied to $v_{\varpi_2}^{\mathbf{d}}$. We conclude $D_{\underline{w}_0}^q \not\subseteq \mathcal{S}_{\text{lm}}$, but $D_{\underline{w}_0}^q \cap \mathcal{S}_{\text{lm}} \neq \emptyset$. We also see, different elements in $D_{\underline{w}_0}^q$ can produce different monomial bases. This observation still holds, even if we consider elements where the sum over the entries is the same.

4.3. Properties of quantum degree cones.

Theorem 3. Let \mathfrak{g} be a simple Lie algebra of rank $n \geq 3$, then

$$\bigcap_{\underline{w}_0 \in R(w_0)} \mathcal{D}_{\underline{w}_0}^q = \emptyset.$$

Proof. Since we calculated the cases $n \leq 2$ explicitly in the examples (see Subsection 4.1), we only consider the case where $n \geq 3$. We want to show that there are at least two reduced decomposition $\underline{w}_0^1, \underline{w}_0^2$ such that the associated cones have inequalities which contradict each other.

First we want to show that we can reduce the statement to the case where $n = 3$. Since \mathfrak{g} is a simple Lie algebra we find a Lie subalgebra $\mathfrak{g}_3 \subset \mathfrak{g}$ of type $\mathbf{A}_3, \mathbf{B}_3$ or \mathbf{C}_3 respectively, denoted by \mathbf{X}_3 . Depending on the type of the Lie subalgebra of \mathfrak{g} we choose a reduced decomposition $\underline{w}_0^{\mathbf{X}_3} \in W_{\mathbf{X}_3}$ of the longest Weyl group element in the Weyl group of \mathfrak{g}_3 . If we have more than one choice, it does not matter which type we choose. Now we consider the longest Weyl group element $w_0 \in W$. We can always find a reduced decomposition \underline{w}_0 of w_0 such that $\underline{w}_0^{\mathbf{X}_3}$ is a subword of \underline{w}_0 , i.e. let $l :=$ number of positive roots of \mathfrak{g}_3 :

$$\underline{w}_0 = \underline{w}_0^{\mathbf{X}_3} s_{i_{l+1}} s_{i_{l+2}} \cdots s_{i_N},$$

where $s_{i_k} \in W$ is the reflection associated to the simple root α_{i_k} . If we prove the statement for Lie algebras of rank $n = 3$ we can extend the cones which have empty intersection. Hence for a Lie algebra of arbitrary rank $n \geq 3$ we find quantum degree cones, associated to certain reduced decompositions, which do not intersect.

Let \mathfrak{g} be of type \mathbf{A}_3 and $U_q(\mathfrak{g})$ be the quantum group associated to \mathfrak{g} with generic parameter q . We consider the reduced decompositions

$$\underline{w}_0^1 = s_1 s_2 s_1 s_3 s_2 s_1, \quad \underline{w}_0^2 = s_1 s_3 s_2 s_3 s_1 s_2$$

of w_0 the longest Weyl group element in $W_{\mathbf{A}_3}$. The quantum PBW root vectors associated to the reduced decompositions are given by

$$F_{1,1}, F_{1,2}, F_{2,2}, F_{1,3}, F_{2,3}, F_{3,3} \quad \text{and}$$

$$F_{1,1}, F_{3,3}, F_{1,3}, F_{1,2}, F_{2,3}, F_{2,2}$$

respectively. Here $F_{i,j}$ denotes the quantum PBW root vector associated to the positive root $\alpha_i + \alpha_{i+1} + \cdots + \alpha_j$ for $i \leq j$. We have the following commutation relations in $U_q(\mathfrak{n}^-)$ (see the L-S formula (3.1)):

$$(1) F_{1,2}F_{2,3} = F_{2,3}F_{1,2} + (q - q^{-1})F_{2,2}F_{1,3} \text{ and}$$

$$(2) F_{1,3}F_{2,2} = F_{2,2}F_{1,3} + (q - q^{-1})F_{1,2}F_{2,3}$$

respectively. Let $\deg F_{1,2} = a_1, \deg F_{2,3} = a_2, \deg F_{1,3} = a_3, \deg F_{2,2} = a_4$. Then we get the following inequalities in $\mathcal{D}_{\underline{w}_0}^q$ and $\mathcal{D}_{\underline{w}_0}^q$ respectively:

$$(1) \Rightarrow a_1 + a_2 > a_3 + a_4 \text{ and}$$

$$(2) \Rightarrow a_3 + a_4 > a_1 + a_2,$$

which implies $\mathcal{D}_{\underline{w}_0}^q \cap \mathcal{D}_{\underline{w}_0}^q = \emptyset$. The proof in the cases of \mathbf{B}_3 and \mathbf{C}_3 proceeds similar:

Let \mathfrak{g} be of type \mathbf{B}_3 and $U_q(\mathfrak{g})$ be the associated quantum group. We consider the reduced decompositions

$$\underline{w}_0^1 = s_1s_2s_1s_3s_2s_1s_3s_2s_3, \quad \underline{w}_0^2 = s_1s_3s_2s_3s_2s_1s_2s_3s_2$$

of w_0 the longest Weyl group element in $W_{\mathbf{B}_3}$. The quantum PBW root vectors, denotes as before, are

$$F_{1,1}, F_{1,2}, F_{2,2}, F_{1,3}, F_{1,\bar{2}}, F_{1,\bar{3}}, F_{2,3}, F_{2,\bar{3}}, F_{3,3} \text{ and}$$

$$F_{1,1}, F_{3,3}, F_{1,\bar{3}}, F_{1,3}, F_{1,2}, F_{1,\bar{2}}, F_{2,\bar{3}}, F_{2,3}, F_{2,2}$$

respectively. Here $F_{i,\bar{j}}$ denotes the quantum PBW root vector associated to the positive root $\alpha_i + \cdots + \alpha_{j-1} + 2\alpha_j + \cdots + 2\alpha_n$ for $1 \leq i < j \leq n = 3$ and denote $F_{i,j}$ as before. We have the following relations in $U_q(\mathfrak{n}^-)$:

$$(1) F_{1,2}F_{2,3} = F_{2,3}F_{1,2} + (q^2 - q^{-2})F_{2,2}F_{1,3} \text{ and}$$

$$(2) F_{1,3}F_{2,2} = F_{2,2}F_{1,3} + (q^2 - q^{-2})F_{1,2}F_{2,3}$$

respectively. Let $\deg F_{1,2} = b_1, \deg F_{2,3} = b_2, \deg F_{1,3} = b_3, \deg F_{2,2} = b_4$. Then we get the following inequalities:

$$(1) \Rightarrow b_1 + b_2 > b_3 + b_4 \text{ and}$$

$$(2) \Rightarrow b_3 + b_4 > b_1 + b_2,$$

which implies $\mathcal{D}_{\underline{w}_0}^q \cap \mathcal{D}_{\underline{w}_0}^q = \emptyset$.

Finally let \mathfrak{g} be of type \mathbf{C}_3 and $U_q(\mathfrak{g})$ be the associated quantum group. We consider the reduced decompositions

$$\underline{w}_0^1 = s_1s_2s_3s_2s_1s_2s_3s_2s_3, \quad \underline{w}_0^2 = s_1s_3s_2s_3s_2s_1s_2s_3s_2$$

of w_0 the longest Weyl group element in $W_{\mathbf{C}_3}$. The quantum PBW root vectors, denoted as in 4.2.1, are given by

$$F_{1,1}, F_{1,2}, F_{1,\bar{1}}, F_{1,3}, F_{1,\bar{2}}, F_{2,2}, F_{2,\bar{2}}, F_{2,3}, F_{3,3} \text{ and}$$

$$F_{1,1}, F_{3,3}, F_{1,3}, F_{1,\bar{1}}, F_{1,2}, F_{1,\bar{2}}, F_{2,3}, F_{2,\bar{2}}, F_{2,2}$$

respectively. Further we have the following relations:

$$(1) F_{1,2}F_{2,3} = q^{-1}F_{2,3}F_{1,2} + (q^2 - q^{-2})F_{1,3}F_{2,2} + qF_{1,\bar{2}} \text{ and}$$

$$(2) F_{1,3}F_{2,2} = q^{-1}F_{2,2}F_{1,3} + (q^2 - q^{-2})F_{1,2}F_{2,3} + qF_{1,\bar{2}}$$

respectively. Let $\deg F_{1,2} = c_1, \deg F_{2,3} = c_2, \deg F_{1,3} = c_3, \deg F_{2,2} = c_4$. Then we get the following inequalities:

$$(1) \Rightarrow c_1 + c_2 > c_3 + c_4 \text{ and}$$

$$(2) \Rightarrow c_3 + c_4 > c_1 + c_2,$$

which implies $\mathcal{D}_{\underline{w}_0^1}^q \cap \mathcal{D}_{\underline{w}_0^2}^q = \emptyset$. \square

The importance of the foregoing result is the following: if the intersection of all quantum degree cones would be non-empty, elements in this intersection would be good candidates to study the corresponding filtration on $U(\mathfrak{n}^-)$ and $U_q(\mathfrak{n}^-)$ respectively. Since this intersection is empty we need to find other conditions.

Two reflections s_p and s_q in W with $p \neq q$ are said to be *orthogonal* if $s_p s_q = s_q s_p$. Two reduced decompositions $\underline{w}_0, \underline{w}'_0 \in R(w_0)$ are said to be *related by orthogonal reflections* if one can be obtained from the other by using only orthogonal reflections.

The following proposition shows that most of the cones are the same.

Proposition 3. Let $\underline{w}_0, \underline{w}'_0 \in R(w_0)$ such that they are related by orthogonal reflections. Then $\mathcal{D}_{\underline{w}_0}^q = \mathcal{D}_{\underline{w}'_0}^q$.

Proof. By definition, it suffices to consider the case where

$$\underline{w}_0 = \underline{w}_L s_p s_q \underline{w}_R, \quad \underline{w}'_0 = \underline{w}_L s_q s_p \underline{w}_R$$

with $1 \leq p, q \leq n$ such that $s_p s_q = s_q s_p$. In this case, Lemma 2 can be applied to prove the proposition. \square

5. LOCAL AND GLOBAL MONOMIAL SETS

5.1. Local and global monomial set. We define the quantum local monomial set and the quantum global monomial set as follows:

$$\mathcal{S}_{\text{lm}}^q := \mathcal{S}_{\text{lm}} \cap \mathcal{D}^q, \quad \mathcal{S}_{\text{gm}}^q := \mathcal{S}_{\text{gm}} \cap \mathcal{D}^q.$$

Proposition 4. For any $\underline{w}_0 \in R(w_0)$, we have $\mathcal{D}_{\underline{w}_0}^q \cap \mathcal{S}_{\text{lm}} \neq \emptyset$. Hence $\mathcal{S}_{\text{lm}}, \mathcal{S}_{\text{lm}}^q \neq \emptyset$.

Proof. We need to find $\mathbf{d} \in \mathcal{D}_{\underline{w}_0}^q$ such that for any $s = 1, \dots, n$, $I^{\mathbf{d}}(\varpi_s)$ is a monomial ideal.

Define $m_i := \langle \rho, \beta_i^\vee \rangle$ for the fixed weight $\rho = \sum_{i=1}^n \varpi_i \in \mathcal{P}_+$. In order to prove the statement we can adapt the proof of Theorem 2. In this proof we construct a $\mathbf{x} \in \mathcal{D}_{\underline{w}_0}^q \cap \mathbb{N}^N$. Note that this \mathbf{x} does not satisfy $x_1 < x_2 < \dots < x_N$, since $x_1 = x_2 = 1$ and if $M_{j,k}^q$ is empty in the k -th step for all $1 \leq j \leq k-2$, then $x_k = 1$.

We change the procedure as follows: we set $d_1 = 1, d_2 = 2$ and $\deg F_{\beta_1} = 1, \deg F_{\beta_2} = 2$. Note that $m_1 = 1$, since β_1 is a simple root. For $3 \leq k \leq N$, in the k -th step we set

$$d_k = 1 + \max \left\{ \sum_{i=1}^{k-1} m_i \deg F_{\beta_i}, \deg(m) \mid m \in M_{j,k}^q, 1 \leq j \leq k-2 \right\}. \quad (5.1)$$

We set $\deg F_{\beta_k} = d_k$ and the step is finished.

With the same arguments as in the proof of Theorem 2, \mathbf{d} satisfies all inequalities of $\mathcal{D}_{\underline{w}_0}^q$ containing only d_1, d_2, \dots, d_k . Since we keep track of the degrees, by setting $\deg F_{\beta_k} = d_k$, the possible choice of $d_k = \sum_{i=1}^{k-1} m_i \deg F_{\beta_i}$ does not change this. After N steps we obtain that $\mathbf{d} \in \mathcal{D}_{\underline{w}_0}^q$ is a solution satisfying $d_1 < d_2 < \dots < d_N$. We turn to the classical case, then we have by the choice of \mathbf{d} (see (5.1))

$$\deg f_{\beta_1}^{m_1} f_{\beta_2}^{m_2} \dots f_{\beta_{k-1}}^{m_{k-1}} < \deg f_{\beta_k}$$

for all $1 \leq k \leq N$. Furthermore $f_{\beta_1}^{m_1} f_{\beta_2}^{m_2} \dots f_{\beta_{k-1}}^{m_{k-1}} f_{l\nu_\rho} = 0$ in $V(\rho)$ for any $1 \leq l \leq k-1$ and hence zero in $V^{\mathbf{d}}(\rho)$. This implies, the choice of $\mathbf{d} \in \mathcal{D}$, in particular the degree on the root vectors $\deg f_{\beta_i} = d_i, 1 \leq i \leq N$ induces a total order, namely the reverse lexicographical order,

on the monomials in $S(\mathfrak{n}^-)$ which are non-zero applied to $v_\rho^{\mathbf{d}}$. Hence $I^{\mathbf{d}}(\varpi_s)$ is monomial for any $1 \leq s \leq n$. \square

Remark 4. If $\mathcal{S}_{\text{gm}} \neq \emptyset$, then there exists an \mathbb{N} -filtration arising from $\mathbf{d} \in \mathcal{S}_{\text{gm}}$ such that for any $\lambda \in \mathcal{P}_+$, $V^{\mathbf{d}}(\lambda)$ has a unique monomial basis.

If $\mathcal{S}_{\text{gm}}^q \neq \emptyset$, then there exists an \mathbb{N} -filtration on $U_q(\mathfrak{n}^-)$ with $S_q(\mathfrak{n}^-)$ the associated graded algebra arising from $\mathbf{d} \in \mathcal{S}_{\text{gm}}^q$ such that for any $\lambda \in \mathcal{P}_+$, $V_q^{\mathbf{d}}(\lambda)$ has a unique monomial basis.

5.2. Global monomial sets: $\mathbf{A}_n, \mathbf{C}_n$. For type \mathbf{A}_n we have the following positive roots: $\alpha_{i,j} = \alpha_i + \alpha_{i+1} + \cdots + \alpha_j, 1 \leq i \leq j \leq n$. In the case of \mathbf{C}_n the positive roots are: $\alpha_{i,j} = \alpha_i + \cdots + \alpha_j, 1 \leq i \leq j \leq n$ and

$$\alpha_{i,\bar{j}} = \alpha_i + \cdots + \alpha_{j-1} + 2\alpha_j + \cdots + 2\alpha_{n-1} + \alpha_n, 1 \leq i \leq j \leq n-1.$$

For a dominant integral weight $\lambda \in \mathcal{P}_+$ we denote the FFL polytopes described in [FFL1] by $P^{\mathbf{A}_n}(\lambda)$ and in [FFL2] by $P^{\mathbf{C}_n}(\lambda)$ respectively.

We turn first to the \mathbf{A}_n case and define \mathbf{d} by $d_{i,j} = (j-i+1)(n-j+1)$ for $1 \leq i \leq j \leq n$ the degree attached to the root vector $f_{i,j}$ of the positive root $\alpha_{i,j}$. The results in [FFR, Theorem A, Theorem C] imply the first two statements of the following theorem:

- Theorem 4.** (1) We have $\mathbf{d} \in \mathcal{S}_{\text{gm}}$.
 (2) The set $\{f^{\mathbf{a}}v_\lambda^{\mathbf{d}} \mid \mathbf{a} \in P_{\mathbb{N}}^{\mathbf{A}_n}(\lambda)\}$ forms a monomial basis of $V^{\mathbf{d}}(\lambda)$.
 (3) Let $\underline{w}_0 = (s_n s_{n-1} \cdots s_1)(s_n \cdots s_2) \cdots (s_n s_{n-1})s_n$, then $\mathbf{d} \in \mathcal{D}_{\underline{w}_0}^q$.

Proof. (3) The reduced decomposition \underline{w}_0 determines the following convex order on the positive roots:

$$\begin{aligned} \alpha_{n,n} \prec \alpha_{n-1,n} \prec \cdots \prec \alpha_{2,n} \prec \alpha_{1,n} \prec \\ \alpha_{n-1,n-1} \prec \cdots \prec \alpha_{1,n-1} \prec \\ \dots \\ \alpha_{2,2} \prec \alpha_{1,2} \prec \\ \alpha_{1,1}. \end{aligned}$$

With root combinatorics we obtain that the defining inequalities of $\mathcal{D}_{\underline{w}_0}^q \subset \mathbb{R}_+^N$ are the following: $\mathbf{x} = (x_{p,q}) \in \mathbb{R}_+^N$: for all $\alpha_{k,i-1}, \alpha_{i,j} \in \Delta_+$:

$$x_{k,i-1} + x_{i,j} > x_{k,j} \quad (5.2)$$

and for all $\alpha_{i,j} \in \Delta_+$ such that there exist $r, s \in \mathbb{N}$, r or s non-zero with $\alpha_{i+r,j}, \alpha_{i,j-s}, \alpha_{i+r,j-s} \in \Delta_+$:

$$x_{i+r,j} + x_{i,j-s} > x_{i,j} + x_{i+r,j-s}. \quad (5.3)$$

Let $\lambda \in \mathcal{P}_+$ such that $f_{i+r,j}v_\lambda^{\mathbf{d}}, f_{i,j-s}v_\lambda^{\mathbf{d}}, f_{i,j}v_\lambda^{\mathbf{d}}, f_{i+r,j-s}v_\lambda^{\mathbf{d}} \neq 0$, for example $\lambda = \rho = \varpi_1 + \varpi_2 + \cdots + \varpi_n$. Since $\alpha_{i+r,j} + \alpha_{i,j-s} = \alpha_{i,j} + \alpha_{i+r,j-s}$ and $f_{i,j}f_{i+r,j-s}v_\lambda^{\mathbf{d}} \neq 0$ in $V^{\mathbf{d}}(\lambda)$, by the description of $P_{\mathbb{N}}^{\mathbf{A}_n}(\lambda)$, we obtain that \mathbf{d} satisfies the inequalities (5.3). A similar arguments works for (5.2). \square

Let us consider the \mathbf{C}_n case. We define $\mathbf{d} \in \mathcal{D}$ by: $d_{i,j} = (2n-j)(j-i+1)$ and $d_{i,\bar{j}} = j(2n-i-j+1)$.

- Conjecture 1.** (1) We have $\mathbf{d} \in \mathcal{S}_{\text{gm}}$. Moreover, $\mathbf{d} \notin \mathcal{D}^q$.
 (2) The set $\{f^{\mathbf{a}}v_\lambda^{\mathbf{d}} \mid \mathbf{a} \in P_{\mathbb{N}}^{\mathbf{C}_n}(\lambda)\}$ forms a monomial basis of $V^{\mathbf{d}}(\lambda)$.

5.3. Global monomial set: \mathbf{C}_2 . Consider the quantum degree cone $\mathcal{D}_{\underline{w}_0}^q$ defined in (4.1). We pick a solution such that the sum $a_1 + a_2 + a_3 + a_4$ takes its minimal value:

$$\mathbf{d} = (d_1, d_{112}, d_{12}, d_2) = (1, 1, 1, 2).$$

Since $\mathbf{d} \in \mathcal{D}$, we go back to the classical case. Let $f_1, f_{112}, f_{12}, f_2$ denote the corresponding PBW root vectors.

Lemma 4. We have $\mathbf{d} \in \mathcal{S}_{\text{lm}}$, i.e., the defining ideals $I^{\mathbf{d}}(\varpi_1)$ and $I^{\mathbf{d}}(\varpi_2)$ are monomial.

Proof. For $V(\varpi_1)$, the weight space of weight $-\varpi_1$ has dimension 1, so we need to choose a monomial having minimal degree from the set $\{f_{112}, f_1 f_{12}, f_1^2 f_2\}$. Since $d_1 + d_{12} > d_{112}$, we should pick f_{112} . The choice in all other weight spaces is obvious, so the defining ideal $I^{\mathbf{d}}(\varpi_1)$ is monomial.

We turn to $V(\varpi_2)$: the weight space of weight $-2\varpi_1 + \varpi_2$ is of dimension 1, for the same reason we should choose the monomial f_{112} from the set $\{f_{112}, f_1 f_{12}\}$; the weight space $-\varpi_2$ has dimension 1, we need to choose a monomial of minimal degree from the set

$$\{m_1 = f_{12}^2, m_2 = f_{112} f_2, m_3 = f_1 f_{12} f_2, m_4 = f_1^2 f_2^2\}.$$

By the inequalities in (4.1), we get: $\deg(m_1) < \deg(m_2)$, $\deg(m_2) < \deg(m_3)$ and $\deg(m_3) < \deg(m_4)$. This implies that the defining ideal $I^{\mathbf{d}}(\varpi_2)$ is monomial. \square

We turn to the study whether \mathbf{d} is in the global monomial set \mathcal{S}_{gm} .

Consider the polytope $\mathbf{SP}_4(m_1, m_2) \subset \mathbb{R}^4$ defined by the following inequalities:

$$\begin{aligned} x_1, x_2, x_3, x_4 &\geq 0, & x_1 &\leq m_1, & x_4 &\leq m_2, \\ 2x_1 + x_2 + 2x_3 + 2x_4 &\leq 2(m_1 + m_2), \\ x_1 + x_2 + x_3 + 2x_4 &\leq m_1 + 2m_2. \end{aligned}$$

Let $S(m_1, m_2)$ denote the lattice points in $\mathbf{SP}_4(m_1, m_2)$.

Theorem 5. For any $\lambda = m_1 \varpi_1 + m_2 \varpi_2 \in \mathcal{P}_+$, the following statements hold:

- (1) The set $\{f^{\mathbf{p}} v_{\lambda}^{\mathbf{d}} \mid \mathbf{p} \in S(m_1, m_2)\}$ forms a monomial basis of $V^{\mathbf{d}}(\lambda)$, hence a monomial basis of $V(\lambda)$.
- (2) We have $\mathbf{d} \in \mathcal{S}_{\text{gm}}$, i.e., the defining ideal $I^{\mathbf{d}}(\lambda)$ is monomial.

The rest of this paragraph will be devoted to prove this theorem.

Proposition 5 (Minkowski property). For any $m_1, m_2, m'_1, m'_2 \in \mathbb{N}$,

$$S(m_1, m_2) + S(m'_1, m'_2) = S(m_1 + m'_1, m_2 + m'_2).$$

Proof. It suffices to prove

$$S(m_1 - 1, m_2) + S(1, 0) = S(m_1, m_2) \text{ and } S(0, m_2 - 1) + S(0, 1) = S(0, m_2).$$

Suppose $m_1 \neq 0$ and $s = (a_1, a_2, a_3, a_4) \in S(m_1, m_2)$. If $a_1 \neq 0$, we set $t_1 = (a_1 - 1, a_2, a_3, a_4)$, $t_2 = (1, 0, 0, 0)$. Then clearly $t_2 \in S(1, 0)$ and since $s \in S(m_1, m_2)$ we have

$$2a_1 + a_2 + 2a_3 + 2a_4 \leq 2(m_1 + m_2) \Rightarrow 2(a_1 - 1) + a_2 + 2a_3 + 2a_4 \leq 2(m_1 - 1 + m_2)$$

$$a_1 + a_2 + a_3 + 2a_4 \leq m_1 + 2m_2 \Rightarrow a_1 - 1 + a_2 + a_3 + 2a_4 \leq (m_1 - 1) + 2m_2$$

and so $t_1 \in S(m_1 - 1, m_2)$. If $a_1 = 0$, $a_3 \neq 0$ the very similar argument, with $t_2 = (0, 0, 1, 0)$ implies again $t_1 \in S(m_1 - 1, m_2)$.

We are left with $a_1 = 0, a_3 = 0, a_2 \neq 0$. But then the inequalities for $s \in S(m_1, m_2)$ are reduced to

$$a_2 + 2a_4 \leq m_1 + 2m_2$$

So we see that $s = (0, a_2 - 1, 0, a_4) + (0, 1, 0, 0)$ gives a decomposition in $(m_1, m_2) + S(1, 0)$. The last case $a_1 = 0, a_2 = 0, a_3 = 0, a_4 \neq 0$ is now obvious.

Suppose now $m_1 = 0$ and $s = (a_1, a_2, a_3, a_4) \in S(0, m_2)$, then $a_1 = 0$ and the inequality $a_2 + a_3 + 2a_4 \leq 2m_2$ is redundant. Suppose $a_3 \neq 0$, then we decompose $s = (0, a_2 - 1, a_3, a_4) + (0, 1, 0, 0)$ and use that

$$a_2 + 2a_3 + 2a_4 \leq 2m_2 \Rightarrow a_2 + 2(a_3 - 1) + 2a_4 \leq 2(m_2 - 1).$$

Having $a_1 = 0, a_3 = 0, a_4 \neq 0$ can be dealt similarly. So we are left with $0 \neq a_2 \leq 2m_2$, so we decompose this in $(0, a_2 - 2, 0, 0) + (0, 2, 0, 0)$ if $a_2 > 2$, else there is nothing to be shown.

This implies that any element in $S(m_1, m_2)$ can be decomposed as the sum of elements in $S(m_1 - k, m_2 - \ell), S(k, \ell)$. \square

From this proposition, $\{f^{\mathbf{p}} v_{\lambda}^{\mathbf{d}} \mid \mathbf{p} \in S(m_1, m_2)\}$ forms a linearly independent set in $V^{\mathbf{d}}(\lambda)$. To show that it is a basis, we count the cardinality.

For any integers $a, b \in \mathbb{N}$, we define a polytope $\mathbf{P}(a, b) \subset \mathbb{R}^2$ by the following inequalities:

$$x \geq 0, \quad y \geq 0, \quad x + 2y \leq a, \quad x + y \leq b.$$

Let $N(a, b)$ denote the number of lattice points in $\mathbf{P}(a, b)$.

Lemma 5. The number of lattice points $N(a, b)$ has the following expression:

$$(1) \quad N(a, a) = \begin{cases} l(l+1) & \text{if } a = 2l - 1; \\ (l+1)^2 & \text{if } a = 2l. \end{cases}$$

$$(2) \quad N(a, b) = \begin{cases} N(a, a), & \text{if } b \geq a; \\ \frac{1}{2}(b+1)(b+2), & \text{if } a \geq 2b; \\ -l^2 + 2lb - \frac{1}{2}b^2 + \frac{1}{2}b + l + 1, & \text{if } 2b > a > b \text{ and } a = 2l; \\ -l^2 + 2lb - \frac{1}{2}b^2 + \frac{3}{2}b + 1, & \text{if } 2b > a > b \text{ and } a = 2l + 1. \end{cases}$$

Proof. It amounts to count the integral points in the closed region cutting by the lines $x + 2y = a, x + y = b$ and the two axes in \mathbb{R}^2 which depends on the position of the intersection of these two lines. \square

Proposition 6. The number of lattice points in $\mathbf{SP}_4(m_1, m_2)$ is

$$\frac{1}{6}(m_1 + 1)(m_2 + 1)(m_1 + m_2 + 2)(m_1 + 2m_2 + 3).$$

Proof. Let H be the intersection of hyperplanes $x_1 = \alpha$ and $x_4 = \beta$ in \mathbb{R}^4 with coordinates (x_1, x_2, x_3, x_4) where $\alpha, \beta \geq 0$. By definition,

$$H \cap \mathbf{SP}_4(m_1, m_2) = \mathbf{P}(2m_1 + 2m_2 - 2\alpha - 2\beta, m_1 + 2m_2 - \alpha - 2\beta).$$

Therefore by Lemma 5, the number of integral points in $\mathbf{SP}_4(m_1, m_2)$ equals

$$\sum_{\alpha=0}^{m_1} \sum_{\beta=0}^{m_2} N(2m_1 + 2m_2 - 2\alpha - 2\beta, m_1 + 2m_2 - \alpha - 2\beta). \quad (5.4)$$

Since $\alpha \leq m_1$ and $\beta \leq m_2$, it falls into the third case in Lemma 5 (2) and (5.4) reads ($l = m_1 + m_2 - \alpha - \beta$ and $b = m_1 + 2m_2 - \alpha - 2\beta$):

$$\sum_{\alpha=0}^{m_1} \sum_{\beta=0}^{m_2} \frac{1}{2} \alpha^2 + 2\alpha\beta + \beta^2 - (m_1 + 2m_2 + \frac{3}{2})\alpha - 2(m_1 + m_2 + 1)\beta + (\frac{1}{2}m_1^2 + 2m_1m_2 + m_2^2 + \frac{3}{2}m_1 + 2m_2 + 1).$$

An easy summation provides the number in the statement. \square

By Weyl character formula, for $\lambda = m_1\varpi_1 + m_2\varpi_2 \in \mathcal{P}_+$,

$$\dim V(\lambda) = \frac{1}{6}(m_1 + 1)(m_2 + 1)(m_1 + m_2 + 2)(m_1 + 2m_2 + 3).$$

This terminates the proof of the statement on the basis. The monomiality of $I^{\mathbf{d}}(\lambda)$ holds by Theorem 1.

Remark 5. Up to permuting the second and the third coordinates, the polytope $\mathbf{SP}_4(m_1, m_2)$ coincides with the one in Proposition 4.1 of [Kir1], which is unimodularly equivalent to the Newton-Okounkov body of some valuation arising from inclusions of (translated) Schubert varieties.

In the \mathfrak{sp}_4 case, there are several other known polytopes parametrizing bases of a finite dimensional irreducible representation $V(\lambda)$. Let us denote:

- (1) $P_1(\lambda)$ to be the chain polytope;
- (2) $P_2(\lambda)$ to be the order polytope;
- (3) $P_3(\lambda)$ to be the string polytope associated to the reduced decomposition $\underline{w}_0 = s_1s_2s_1s_2$;
- (4) $P_4(\lambda)$ to be the string polytope associated to the reduced decomposition $\underline{w}_0 = s_2s_1s_2s_1$.

For $\lambda = m_1\varpi_1 + m_2\varpi_2$, the polytopes $\mathbf{SP}_4(m_1, m_2)$, $P_1(\lambda)$, $P_2(\lambda)$, $P_3(\lambda)$ and $P_4(\lambda)$ have the same number of lattice points. By using POLYMAKE, one can verify the following statements:

- (1) The polytopes $P_1(\lambda)$, $P_2(\lambda)$ and $P_4(\lambda)$ are unimodularly equivalent. (The isomorphism between $P_1(\lambda)$ and $P_2(\lambda)$ is proved in [Fou16]).
- (2) The polytopes $P_3(\lambda)$ and $\mathbf{SP}_2(m_1, m_2)$ are not unimodularly equivalent to any other polytopes.

5.4. Global monomial sets: B_3, D_4, G_2 .

5.4.1. D_4 . Let \mathfrak{g} be of type D_4 . We consider the following reduced decomposition

$$\underline{w}_0 = s_2s_1s_2s_3s_2s_4s_2s_1s_2s_3s_2s_4$$

and the resulting quantum PBW root vectors, where F_{abcd} is the root vector associated to the root $a\alpha_1 + b\alpha_2 + c\alpha_3 + d\alpha_4$:

$$F_{0100}, F_{1100}, F_{1000}, F_{1110}, F_{0110}, F_{1211}, F_{1101}, F_{1111}, F_{0010}, F_{0111}, F_{0101}, F_{0001}$$

The quantum degree cone $\mathcal{D}_{\underline{w}_0}^q$ is defined by: $(d_1, d_2, \dots, d_{12}) \in \mathbb{R}_+^{12}$

$$\begin{aligned} d_1 + d_3 &> d_2, & d_1 + d_8 &> d_5 + d_7, & d_1 + d_8 &> d_6, & d_1 + d_9 &> d_5, & d_1 + d_{12} &> d_{11} \\ d_2 + d_8 &> d_3 + d_5 + d_7, & d_2 + d_8 &> d_3 + d_6, & d_2 + d_8 &> d_4 + d_7, & d_2 + d_9 &> d_3 + d_5, \\ d_2 + d_9 &> d_4, & d_2 + d_{10} &> d_6, & d_2 + d_{12} &> d_3 + d_{11}, & d_2 + d_{12} &> d_7 \\ d_3 + d_5 &> d_4, & d_3 + d_{10} &> d_7 + d_9, & d_3 + d_{10} &> d_8, & d_3 + d_{11} &> d_7 \\ d_4 + d_{10} &> d_5 + d_7 + d_9, & d_4 + d_{10} &> d_5 + d_8, & d_4 + d_{10} &> d_6 + d_9 \\ d_4 + d_{11} &> d_5 + d_7, & d_4 + d_{11} &> d_6, & d_4 + d_{12} &> d_8 \\ d_5 + d_7 &> d_6, & d_5 + d_{12} &> d_9 + d_{11}, & d_5 + d_{12} &> d_{10} \\ d_5 + d_7 &> d_6, & d_5 + d_{12} &> d_9 + d_{11}, & d_5 + d_{12} &> d_{10} \\ d_6 + d_{12} &> d_7 + d_9 + d_{11}, & d_6 + d_{12} &> d_7 + d_{10}, & d_6 + d_{12} &> d_8 + d_{11}, \\ d_7 + d_9 &> d_8, & d_9 + d_{11} &> d_{10}. \end{aligned}$$

Let $\mathbf{d} = (5, 5, 1, 2, 4, 1, 1, 2, 6, 10, 12, 20) \in \mathbb{N}^{12}$, we obtain $\mathbf{d} \in \mathcal{D}_{\underline{w}_0}^q$. Since $\mathbf{d} \in \mathcal{D}$, we turn to the classical case and denote by f_i the PBW root vector corresponding to the i -th quantum PBW root vector above (from left to right).

Proposition 7. We have $\mathbf{d} \in \mathcal{S}_{\text{lm}}$.

Proof. For $V^{\mathbf{d}}(\varpi_1)$ we choose f_3f_6 over f_2f_8 and over f_4f_7 , since $\deg f_3f_6 = 2, \deg f_2f_8 = 7$ and $\deg f_4f_7 = 3$. For all other weight spaces the choice is obvious since $\mathbf{d} \in \mathcal{D}$.

Similarly we choose f_5f_8 over f_6f_9 and $f_{10}f_4$ for $V^{\mathbf{d}}(\varpi_3)$ and $f_{10}f_7$ over $f_{10}f_8$ and f_6f_{12} for $V^{\mathbf{d}}(\varpi_4)$.

For $V^{\mathbf{d}}(\varpi_2)$ we have to consider more weight spaces. We illustrate the proof for the zero weight space $V^{\mathbf{d}}(\varpi_2)_{\varpi_2 - \varpi_2}$ of dimension 4. We need to choose the 4 minimal monomials, regarding the degree, of the following set where we neglect the obviously larger monomials.

$$\{m_1 = f_6, m_2 = f_2f_{10}, m_3 = f_1f_8, m_4 = f_4f_{11}, m_5 = f_5f_7\}$$

We have $\deg m_1 = 5, \deg m_2 = 15, \deg m_3 = 7, \deg m_4 = 14$ and $\deg m_5 = 5$. Hence we pick m_1, m_3, m_4, m_5 .

The computation of the other weight spaces is straight forward. We obtain a unique monomial basis for all $V^{\mathbf{d}}(\varpi_i), 1 \leq i \leq 4$ and hence the monomiality of $I^{\mathbf{d}}(\varpi_i)$. \square

Let $P^{\mathbf{d}_4}(\lambda)$ be the polytope defined in [Gor2, Section 3]. By comparing vectors we obtain

$$P_{\mathbb{N}}^{\mathbf{d}_4}(\varpi_i) = \{\mathbf{s} \in \mathbb{N}^{12} \mid f^{\mathbf{s}}v_{\varpi_i}^{\mathbf{d}} \neq 0 \text{ in } V^{\mathbf{d}}(\varpi_i)\}, \quad i = 1, 2, 3, 4.$$

The polytope satisfies for all $\lambda, \mu \in \mathcal{P}_+$ we have

$$P^{\mathbf{d}_4}(\lambda) + P^{\mathbf{d}_4}(\mu) = P^{\mathbf{d}_4}(\lambda + \mu) \text{ and } P_{\mathbb{N}}^{\mathbf{d}_4}(\lambda) + P_{\mathbb{N}}^{\mathbf{d}_4}(\mu) = P_{\mathbb{N}}^{\mathbf{d}_4}(\lambda + \mu)$$

and $\dim V(\lambda) = |P_{\mathbb{N}}^{\mathbf{d}_4}(\lambda)|$. Hence with Theorem 1 we obtain the following theorem:

Theorem 6. (1) We have $\mathbf{d} \in \mathcal{S}_{\text{gm}}$. Moreover, $\mathbf{d} \in \mathcal{D}_{\underline{w}_0}^g$.

(2) The set $\{f^{\mathbf{a}}v_{\lambda}^{\mathbf{d}} \mid \mathbf{a} \in S_{\mathbb{D}_4}(\lambda)\}$ forms a monomial basis of $V^{\mathbf{d}}(\lambda)$.

5.4.2. \mathbf{B}_3 . Let \mathfrak{g} be of type \mathbf{B}_3 and denote by $P^{\mathbf{B}_3}(\lambda)$ the polytope defined in [BK, Section 5]. Here $f_{i,\bar{j}}$ denotes the PBW root vector associated to the positive root $\alpha_i + \dots + \alpha_{j-1} + 2\alpha_j + \dots + 2\alpha_n$ for $1 \leq i < j \leq n = 3$ and denote $f_{i,j}$ as usual. We consider the following degree on the root vectors:

$$\deg f_{1,1} = 4, \deg f_{1,2} = 3, \deg f_{2,2} = 3, \deg f_{1,3} = 3, \deg f_{1,\bar{2}} = 1$$

$$\deg f_{1,\bar{3}} = 1, \deg f_{2,3} = 4, \deg f_{2,\bar{3}} = 3, \deg f_{3,3} = 2.$$

We set d_i to be the i -th degree above and define $\mathbf{d} = (d_1, \dots, d_9)$. The classical degree cone is defined by: $(d_{1,1}, d_{1,2}, d_{2,2}, d_{1,3}, d_{2,3}, d_{3,3}, d_{1,\bar{3}}, d_{2,\bar{3}}, d_{1,\bar{2}}) \in \mathbb{R}_+^9$:

$$d_{1,1} + d_{2,2} > d_{1,2}, \quad d_{1,1} + d_{2,3} > d_{1,3}, \quad d_{1,1} + d_{2,\bar{3}} > d_{1,\bar{3}}, \quad d_{1,2} + d_{3,3} > d_{1,3},$$

$$d_{1,2} + d_{2,\bar{3}} > d_{1,\bar{2}}, \quad d_{2,2} + d_{3,3} > d_{2,3}, \quad d_{2,2} + d_{1,\bar{3}} > d_{1,\bar{2}},$$

$$d_{1,3} + d_{2,3} > d_{1,\bar{2}}, \quad d_{1,3} + d_{3,3} > d_{1,\bar{3}}, \quad d_{2,3} + d_{3,3} > d_{2,\bar{3}}.$$

We obtain $\mathbf{d} \in \mathcal{D}$. As before by computing each weight space in $V^{\mathbf{d}}(\varpi_i), i = 1, 2, 3$ we obtain $\mathbf{d} \in \mathcal{S}_{\text{lm}}$. By comparing the induced unique basis with the basis obtain in loc. cit. we see

$$P_{\mathbb{N}}^{\mathbf{B}_3}(\varpi_i) = \{\mathbf{s} \in \mathbb{N}^9 \mid f^{\mathbf{s}}v_{\varpi_i}^{\mathbf{d}} \neq 0 \text{ in } V^{\mathbf{d}}(\varpi_i)\}, \quad i = 1, 2, 3.$$

For each $\lambda, \mu \in \mathcal{P}_+$ we have

$$P^{\mathbf{B}_3}(\lambda) + P^{\mathbf{B}_3}(\mu) = P^{\mathbf{B}_3}(\lambda + \mu) \text{ and } P_{\mathbb{N}}^{\mathbf{B}_3}(\lambda) + P_{\mathbb{N}}^{\mathbf{B}_3}(\mu) = P_{\mathbb{N}}^{\mathbf{B}_3}(\lambda + \mu)$$

and $\dim V(\lambda) = |P_{\mathbb{N}}^{\mathbf{B}_3}(\lambda)|$. Hence we get the first two statements of the following theorem:

Theorem 7. (1) We have $\mathbf{d} \in \mathcal{S}_{\text{gm}}$.

(2) The set $\{f^{\mathbf{a}}v_{\lambda}^{\mathbf{d}} \mid \mathbf{a} \in P_{\mathbb{N}}^{\mathbf{B}_3}(\lambda)\}$ forms a monomial basis of $V^{\mathbf{d}}(\lambda)$.

(3) For all $\mathbf{d} \in \mathcal{D}$, such that (1) and (2) are satisfied, we have $\mathbf{d} \notin \mathcal{D}^q$.

Proof. Let $\mathbf{d} \in \mathcal{D}$, such that (2) is satisfied. This implies that $f_{1,2}f_{1,\bar{3}}v_{\varpi_2}^{\mathbf{d}} \neq 0$ in $V^{\mathbf{d}}(\varpi_2)$. The monomial $f_{1,3}^2 \in U(\mathfrak{n}^-)$ has the same weight, so we know $f_{1,3}^2v_{\varpi_2}^{\mathbf{d}} = 0$, since the corresponding weight space is one-dimensional.

Assume \underline{w}_0 is a reduced decomposition of w_0 such that $\mathbf{d} \in \mathcal{D}_{\underline{w}_0}^q$. The induced convex order contains the roots $\beta_i = \alpha_{1,2}$ and $\beta_j = \alpha_{1,\bar{3}}$ and $\beta_k = \alpha_{1,3}$. We can assume wlog $i < j$.

Case 1: Assume $i < k < j$, for the quantum degree cone $\mathcal{D}_{\underline{w}_0}^q$ this would imply the following inequality: $d_{1,2} + d_{1,\bar{3}} > 2d_{1,3}$. This implies, turning to the classical case, $f_{1,3}^2v_{\varpi_2}^{\mathbf{d}} \neq 0$, which is a contradiction.

Case 2: Assume $k < i < j$, i.e the roots are distributed as follows

$$\beta_k = \alpha_{1,3}, \quad \beta_i = \alpha_{1,2}, \quad \beta_j = \alpha_{1,\bar{3}}, \quad (\beta_l = \alpha_{3,3}).$$

Consider the root $\beta_l = \alpha_{3,3}$. Since $\alpha_{1,3} + \alpha_{3,3} = \alpha_{1,\bar{3}}$ we have $j < l$ by the convexity of the order. On the opposite $\alpha_{1,2} + \alpha_{3,3} = \alpha_{1,3}$, implying $\alpha_{1,3}$ has to lie between $\alpha_{1,2}$ and $\alpha_{3,3}$ implying $i < k$. This is again a contradiction.

Case 3: Assume $i < j < k$, with similar arguments as in Case 2 we get a contradiction.

None of the cases is possible, implying $\mathbf{d} \notin \mathcal{D}_{\underline{w}_0}^q$. \square

5.4.3. \mathbf{G}_2 . Let \mathfrak{g} be of type \mathbf{G}_2 and consider the following degree on the root vectors:

$$\deg f_1 = 2, \quad \deg f_{1112} = 1, \quad \deg f_{112} = 3, \quad \deg f_{11122} = 1, \quad \deg f_{12} = 3, \quad \deg f_2 = 2.$$

We set d_i to be the i -th degree above and define $\mathbf{d} = (d_1, \dots, d_6)$. We already saw that $\mathbf{d} \in \mathcal{D}$, see Subsection 4.1.3. Denote by $P^{\mathbf{G}_2}(\lambda)$ the polytope defined in [Gor1, Section 1]. With similar arguments and calculations as before we obtain the first two statements of the following theorem. The third statement follows from Subsection 5.6, where we examine the case of \mathbf{G}_2 explicitly. We show for all $\mathbf{d} \in \mathcal{D}_{\underline{w}_0}^q$ there exist a unique monomial basis of $V^{\mathbf{d}}(\varpi_i)$, $i = 1, 2$ which does not coincide with the basis in the following theorem.

Theorem 8. (1) We have $\mathbf{d} \in \mathcal{S}_{\text{gm}}$.

(2) The set $\{f^{\mathbf{a}}v_{\lambda}^{\mathbf{d}} \mid \mathbf{a} \in P_{\mathbb{N}}^{\mathbf{G}_2}(\lambda)\}$ forms a monomial basis of $V^{\mathbf{d}}(\lambda)$.

(3) For all $\mathbf{d} \in \mathcal{D}$, such that (1) and (2) are satisfied, we have $\mathbf{d} \notin \mathcal{D}^q$.

Remark 6. In general, it may hold that $\mathcal{S}_{\text{gm}} \cap \mathcal{D}^q = \emptyset$, see Subsection 5.6 for an example.

5.5. **Global monomial sets for rectangular weights: A – G.** Throughout this subsection we fix a Lie algebra \mathfrak{g} of type \mathbf{X}_n and fundamental weight ω_i of the following list (see [BD, Introduction, Table 1]):

| Type of \mathfrak{g} | weight ϖ | Type of \mathfrak{g} | weight ϖ_i |
|------------------------|------------------------------------|------------------------|----------------------|
| \mathbf{A}_n | $\varpi_k, 1 \leq k \leq n$ | \mathbf{E}_6 | ϖ_1, ϖ_6 |
| \mathbf{B}_n | ϖ_1, ϖ_n | \mathbf{E}_7 | ϖ_7 |
| \mathbf{C}_n | ϖ_1 | \mathbf{F}_4 | ϖ_4 |
| \mathbf{D}_n | $\varpi_1, \varpi_{n-1}, \varpi_n$ | \mathbf{G}_2 | ϖ |

The authors show that there is a normal polytope $P_{\mathbb{N}}^{\mathbf{X}_n}(m\varpi_i)$ such that $\{f^{\mathbf{s}}v_{\varpi_i} \mid \mathbf{s} \in P_{\mathbb{N}}^{\mathbf{X}_n}(m\varpi_i)\}$ is a monomial basis of $V(m\varpi_i)$. In particular $P_{\mathbb{N}}^{\mathbf{X}_n}(m\varpi_i) + P_{\mathbb{N}}^{\mathbf{X}_n}(l\varpi_i) = P_{\mathbb{N}}^{\mathbf{X}_n}((m+l)\varpi_i)$.

With similar arguments as in 5.4 we see in the cases of (\mathbf{B}_n, ϖ_1) and (\mathbf{G}_2, ϖ_1) there exists $\mathbf{d} \in \mathcal{D}$ such that $\{f^{\mathbf{s}}v_{m\varpi_i}^{\mathbf{d}} \mid \mathbf{s} \in P_{\mathbb{N}}^{\mathbf{X}_n}(m\varpi_i)\}$ is a monomial basis of $V^{\mathbf{d}}(m\varpi_i)$, and for all those $\mathbf{d} \in \mathcal{D}$ we have $\mathbf{d} \notin \mathcal{D}_{\underline{w}_0}^q$. In (\mathbf{C}_n, ϖ_1) there is nothing to show. We assume we are not in those cases, then we get the following Theorem.

Theorem 9. There exists a reduced expression \underline{w}_0 of $w_0 \in W_{\mathfrak{X}_n}$ and $\mathbf{d} \in \mathcal{D}_{\underline{w}_0}^q$ such that $\{f^{\mathbf{s}}v_{\varpi_i}^{\mathbf{d}} \mid \mathbf{s} \in P_{\mathbb{N}}^{\mathfrak{X}_n}(m\varpi_i)\}$ is a monomial basis of $V^{\mathbf{d}}(m\varpi_i)$ and the ideal $I^{\mathbf{d}}(m\varpi_i)$ is monomial.

Proof. We denote by $\Delta_+^i = \{\nu_1, \nu_2, \dots, \nu_s\}$ the set of positive roots which satisfy $f_{\nu}v_{\varpi_i} \neq 0$ in $V(\varpi_i)$ and let $\nu_s = \theta$ the highest root. Further we assume the roots are good ordered, i.e. $\nu_i <_{\text{st}} \nu_j$ implies $i < j$ where $<_{\text{st}}$ denotes the standard partial order on the positive roots. Note this determines $\nu_1 = \alpha_i$. We want to show that we can extend the order $\nu_1 < \nu_2 < \dots < \nu_s$ to a convex order on Δ_+ . Since Δ_+^i is good ordered there are no convexity relations between these roots if the coefficient of α_i in θ is 1. So we can extend it for (E_6, ϖ_1) , (E_6, ϖ_6) , (E_7, ϖ_7) , (A_n, ϖ_k) and (D_n, ϖ_{n-1}) , (D_n, ϖ_n) \square

5.6. Local monomial sets: \mathbf{G}_2 . Let \mathfrak{g} be of type \mathbf{G}_2 . Recall that we computed the quantum degree cone $\mathcal{D}_{\underline{w}_0}^q$ in (4.2). Let $\mathbf{d} \in \mathcal{D}_{\underline{w}_0}^q$ be arbitrary. We have $\mathbf{d} \in \mathcal{D}$, so we turn to the classical case and let $f_1, f_{1112}, f_{112}, f_{11122}, f_{12}, f_2$ be the corresponding PBW root vectors.

Lemma 6. The defining ideals $I^{\mathbf{d}}(\varpi_1)$ and $I^{\mathbf{d}}(\varpi_2)$ are monomial.

Proof. For $V(\varpi_1)$, the weight space of weight $-\varpi_1$ has dimension 1, so as in Lemma 4 we need to choose a monomial having minimal degree from the set $\{f_{11122}f_1, f_{1112}f_{12}, f_{112}^2\}$. In the quantum group we have the relations

$$F_1F_{11122} = F_{11122}F_1 + (q - q^{-3})F_{112}^{(2)}, \quad F_{1112}F_{12} = F_{12}F_{1112} + (q - q^{-3})F_{112}^{(2)} \quad (5.5)$$

implying that we should pick f_{112}^2 . As before the choice in all other weight spaces is obvious, so the defining ideal $I^{\mathbf{d}}(\varpi_1)$ is monomial.

We turn to $V(\varpi_2)$: the weight space of weight 0 is of dimension 2, so we need to exclude the monomial having the highest degree from the set $\{f_{1112}f_2, f_{112}f_{12}, f_{11122}\}$. In the quantum group we have the relation

$$F_{1112}F_2 = q^{-3}F_2F_{1112} + (-q^{-3} - q^{-5})F_{112}F_{12} + (q^{-2} + q^{-4} - q^{-7})F_{11122},$$

implying the inequalities $\deg(f_{1112}) + \deg(f_2) > \deg(f_{11122})$ and $\deg(f_{1112}) + \deg(f_2) > \deg(f_{112}) + \deg(f_{12})$, so we should exclude $f_{1112}f_2$.

All other weight spaces have dimension 1, we need to choose one monomial for each weight space. For the weight space $-3\varpi_1 + \varpi_2$ we choose $f_{112}^{(3)}$ from the set $\{f_{1112}f_{11122}, f_{112}^{(3)}\}$ since we have $d_{1112} + d_{11122} > 3d_{112}$. With similar arguments we choose for the weight space $3\varpi_1 - 2\varpi_2$ the monomial $f_{12}^{(3)}$ from the set $\{f_{11122}f_2, f_{12}^{(3)}\}$; for the weight space $2\varpi_1 - \varpi_2$ we choose $f_{12}^{(2)}$ above $f_{112}f_2$; for the weight space $-2\varpi_1 + \varpi_2$ we choose $f_{112}^{(2)}$ above $f_{1112}f_{12}$. The choice in all other weight spaces is obvious. This implies that the defining ideal $I^{\mathbf{d}}(\varpi_2)$ is monomial. \square

Remark 7. The Equation 5.5 implies that we pick f_{112}^2 over $f_{11122}f_1$ in $V^{\mathbf{d}}(\varpi_1)$. The later is the choice in [Gor1]. Since the choice is independent of $\mathbf{d} \in \mathcal{D}_{\underline{w}_0}^q$ this finishes the proof of Theorem 8 statement (3).

Let $S(\varpi_2) = \{\mathbf{s} \in \mathbb{N}^6 \mid f^{\mathbf{s}}v_{\lambda}^{\mathbf{d}} \neq 0\}$. We have by construction $|S(\varpi_2)| = \dim V(\varpi_2) = 14$. But, if we take the convex hull $P = \text{conv}(S(\varpi_2))$, we obtain a polytope which satisfies $|P \cap \mathbb{N}^6| = 16$.

Therefore we consider the following polytopes. Define $\mathbf{G}_2^{\omega_1}(m_1) \subset \mathbb{R}^6$ by the inequalities:

$$\begin{aligned} x_1, x_2, x_3, x_4, x_5, x_6 &\geq 0, & x_1 &\leq m_1, & x_2 &\leq 0, \\ 2x_1 + 2x_2 + x_3 + 2x_4 + 2x_5 &\leq 2m_1. \end{aligned}$$

Define $\mathbf{G}_2^{\omega_2}(m_2) \subset \mathbb{R}^6$ by the inequalities:

$$x_1, x_2, x_3, x_4, x_5, x_6 \geq 0, \quad x_1 \leq 0,$$

$$2x_2 + x_3 + x_4 + x_5 + 2x_6 \leq 2m_2.$$

Conjecture 2. For all $\lambda = m_1\varpi_1 + m_2\varpi_2 \in \mathcal{P}_+$ the number of lattice points in the Minkowski sum

$$m_1\mathbf{G}_2^{\omega_1}(1) + m_2(\mathbf{G}_2^{\omega_2}(1) \cup \{3e_3, 3e_5\})$$

coincides with $\dim V(m_1\omega_1 + m_2\omega_2)$.

Remark 8. Note that the proof of Lemma 6 does not depend on the choice of $\mathbf{d} \in \mathcal{D}_{\underline{w}_0}^q$. Further we have $\mathcal{D}^q = \mathcal{D}_{\underline{w}_0}^q$ (see Proposition 2). This implies the inclusion $\mathcal{D}^q \subset \mathcal{S}_{\text{lm}}$. Depending on whether the conjectures are true or not, we obtain $\mathcal{D}^q \subset \mathcal{S}_{\text{gm}}$ or $\mathcal{S}_{\text{gm}} \cap \mathcal{D}^q = \emptyset$ respectively.

6. DISCUSSION

We refer to the notation of Section 1. In this section we want to discuss our results and state the ideas of our proofs. We shall also show the difficulties in the proofs and discuss possible generalizations.

6.1. Hilbert–Poincaré polynomials. In the first paper we state the degree of the Hilbert–Poincaré polynomial $p_\lambda(q)$ for arbitrary $\lambda \in P^+$. This is done by investigating the lowest weight space $V(\lambda)_{w_0(\lambda)}$ and determining the degree of the lowest weight vector $v_{w_0(\lambda)}$. We already stated in the introduction why this is sufficient in order to compute the PBW-degree.

The PBW filtration is compatible with the decomposition into \mathfrak{h} -weight spaces:

$$\dim V(\lambda)_\tau = \sum_{s \geq 0} \dim (V(\lambda)_s / V(\lambda)_{s-1}) \cap V(\lambda)_\tau.$$

So we can define for every weight $\tau \in P$ the Hilbert–Poincaré polynomial:

$$p_{\lambda,\tau}(q) = \sum_{s \geq 0} \dim (V(\lambda)_s / V(\lambda)_{s-1})_\tau q^s \text{ and then } p_\lambda(q) = \sum_{\tau \in P} p_{\lambda,\tau}(q).$$

A natural question is, if we can extend our results to these polynomials. If the weight space $V(\lambda)_\tau$ is one-dimensional, then $p_{\lambda,\tau}(q)$ is a power of q . To compute this power one could use the same methods we used. We have to find a suitable monomial $u \in U(\mathfrak{n}^-)$ such that the weight of (uv_λ) equals τ and have to show that there is no monomial with smaller degree satisfying this. The action of $U(\mathfrak{n}^+)$ on $V(\lambda)^a$ is a useful tool to show that certain elements are zero.

For $\tau = \lambda$, since $V(\lambda)_\lambda = \mathbb{C}v_\lambda = V(\lambda)_0$, we have $p_{\lambda,\lambda}(q)$ is constant 1. For $\tau = w_0(\lambda)$, the lowest weight, this is $q^{\deg p_\lambda(q)}$. A first approach to study these polynomials can be found in [CF15].

In this paper the reduction is provided, such that in Theorem 1 it suffices to consider fundamental weights (see loc. cit. Theorem 5.3 ii):

Theorem. *Let $\lambda_1, \dots, \lambda_s \in P^+$ and set $\lambda = \lambda_1 + \dots + \lambda_s$. Then*

$$\deg p_\lambda(q) = \deg p_{\lambda_1}(q) + \dots + \deg p_{\lambda_s}(q).$$

Since $\lambda \in P^+$ can be written in terms of fundamental weights $\lambda = m_1\omega_1 + m_2\omega_2 + \dots + m_n\omega_n$ it suffices to compute the PBW-degree of PBW-graded modules of fundamental modules. In the second paper we provide an explicit list in 2.3 of the monomials mapping the highest weight vector to the lowest weight vector for all fundamental weights. Then we show that there is no monomial of smaller degree satisfying this. Here we use mainly the action of $U(\mathfrak{n}^+)$ on $V(\lambda)^a$ and weight combinatorics. For a fixed fundamental highest weight ω_i we write $-w_0(\omega_i) + \omega_i$, which is the weight of a possible monomial $u \in U(\mathfrak{n}^-)$ mapping v_{ω_i} to $v_{w_0(\omega_i)}$, as a sum of positive roots with a minimal amount of summands. We obtain certainly a lower bound, which is in general not the PBW-degree. This occurs in some exceptional types and also for some cases in type B_n and D_n , this was also noticed in [CF15]. We did not find a general rule whether the PBW-degree is given by this lower bound or not.

An upper estimate can be obtained as follows: recall that θ denotes the highest root of \mathfrak{g} , then $f_{\theta}^{\langle \omega_i, \theta^\vee \rangle} v_{\omega_i} \neq 0$ and the weight $\omega_i - \langle \omega_i, \theta^\vee \rangle \theta$ is a weight for a Lie subalgebra $\mathfrak{g}_1 \subset \mathfrak{g}$, see Subsection 2.3 for the explicit list of Lie subalgebras. Denote by θ_1 the corresponding highest root. Then we obtain $f_{\theta_1}^{\langle \omega_i, \theta_1^\vee \rangle} f_{\theta}^{\langle \omega_i, \theta^\vee \rangle} v_{\omega_i} \neq 0$. If we repeat this procedure we end up in the lowest weight space $V(\omega_i)_{w_0(\omega_i)}$. In some cases this upper bound gives the PBW-degree. Again we did not find a general rule whether this is the case or not.

6.2. Favourable modules via Hasse diagrams. First, we want to note that the authors in [FFL13b] introduced the notion of a favourable module. In the second paper we call these modules Feigin–Fourier–Littelmann (FFL for short) modules. Since we denote these modules in the third paper again as favourable modules, we shall stick to this notion.

We fix a Lie algebra \mathfrak{g} and consider the partial order \leq on the positive roots of \mathfrak{g} , given by $\alpha, \beta \in R^+ : \alpha \leq \beta \Leftrightarrow \beta - \alpha$ is a non-negative sum of simple roots. We associate to this partially ordered set (R^+, \leq) a directed labeled graph (R^+, E) , called the Hasse diagram. The vertices are given by R^+ and the set E is given as follows:

$$\forall \alpha, \beta \in R^+ : (\alpha \xrightarrow{k} \beta) \in E \Leftrightarrow \exists \alpha_k \in \Delta : \alpha - \beta = \alpha_k,$$

recall that Δ denotes the set of simple roots of \mathfrak{g} . We denote by \mathbf{D} the set of all directed paths, which we call Dyck paths, $\mathbf{p} = \{\beta_{i_1}, \beta_{i_2}, \dots, \beta_{i_s}\}$ starting in $\beta_{i_1} = \theta$ the highest root of \mathfrak{g} and ending in a simple root $\beta_{i_s} = \alpha_j$, $1 \leq j \leq n$, such that there is a directed edge between β_{i_l} and $\beta_{i_{l+1}}$, $1 \leq l \leq s-1$.

We fix the type of the highest weight to be a multiple of a fundamental weight, $\lambda = m\omega_i$, $m \in \mathbb{N}$, $1 \leq i \leq n = \text{rank } \mathfrak{g}$ and associate to the Hasse diagram a polytope:

$$P(m\omega_i) = \{(s_\beta)_{\beta \in R^+} \in \mathbb{R}_{\geq 0}^N \mid \sum_{\beta \in \mathbf{p}} s_\beta \leq m \ \forall \mathbf{p} \in \mathbf{D}, \ s_\beta \leq 0 \text{ if } f_\beta v_{\omega_i} = 0\}.$$

We show that this polytope is normal (see Subsection 3.2). The question arises how this polytope is related to the module $V(m\omega_i)$. The condition $s_\beta \leq 0$ for all $\beta \in R^+$ such that $f_\beta v_{\omega_i} = 0$ shows one relationship. Meaning that we only want to consider vectors in $\mathbb{R}_{\geq 0}^N$, such that the corresponding root vectors act non-zero on v_{ω_i} . Another relationship is slightly more hidden. We assume that ω_i satisfies $\langle \omega_i, \theta^\vee \rangle = 1$. Then we know $f_\theta^m v_{m\omega_i} \neq 0$ and $f_\theta^{m+1} v_{m\omega_i} = 0$ in $V(m\omega_i)$ and the second observation also holds in $V(m\omega_i)^a$. This means the right-hand sides of the inequalities of $P(m\omega_i)$ are related to certain relations in $V(m\omega_i)$, in particular to relations including the root vector corresponding to the highest root.

If \mathfrak{g} and ω_i appear in the table below, then we prove that the cardinality of the lattice points $P_{\mathbb{N}}(\omega_i) = P(\omega_i) \cap \mathbb{N}^N$ is equal to the dimension of $V(\omega_i)$. We show this by constructing explicit basis of $V(\omega_i)$ in the corresponding cases, see Subsection 3.4. Outside these cases this equality does not hold and hence our approach can not be generalized immediately to other cases. A generalization can be found in the third paper, we explain this also later in this section and in Subsection 6.3.

| Type of \mathfrak{g} | weight ω | Type of \mathfrak{g} | weight ω |
|------------------------|------------------------------------|------------------------|----------------------|
| A_n | $\omega_k, 1 \leq k \leq n$ | E_6 | ω_1, ω_6 |
| B_n | ω_1, ω_n | E_7 | ω_7 |
| C_n | ω_1 | F_4 | ω_4 |
| D_n | $\omega_1, \omega_{n-1}, \omega_n$ | G_2 | ω_1 |

The observation $|P_{\mathbb{N}}(\omega_i)| = \dim V(\omega_i)$ starts an inductive procedure. By refining the partial order on R^+ to a total order and choosing an induced homogeneous lexicographical total order on the monomials in $U(\mathfrak{n}^-)$ we find that $P_{\mathbb{N}}(\omega_i) = \text{es}(V(\omega_i))$. We use the following result (see [FFL13b, Prop. 2.11])

$$\text{es}(V(\omega_i)) + \text{es}(V(\omega_i)) \subset \text{es}(V(\omega_i) \odot V(\omega_i)),$$

where $+$ denotes the Minkowski sum and $V(\omega_i) \odot V(\omega_i) \subset V(\omega_i) \otimes V(\omega_i)$ denotes the Cartan component in the tensor product. Hence we obtain $|P_{\mathbb{N}}(2\omega_i)| \leq \dim V(2\omega_i)$. We show in general that the set

$$\{f^{\mathbf{s}}v_{m\omega_i}^a \mid \mathbf{s} \in P_{\mathbb{N}}(m\omega_i)\} \subset V(m\omega_i)^a$$

is a spanning set of $V(m\omega_i)^a$. Hence we have for all $m \in \mathbb{N}$ the inequality $\dim V(m\omega_i) = \dim V(m\omega_i)^a \geq |P_{\mathbb{N}}(m\omega_i)|$ and especially $|P_{\mathbb{N}}(2\omega_i)| = \dim V(2\omega_i)$. By repeating these arguments we obtain a proof of the Main Theorem 2. We obtain immediately that the module $V(m\omega_i)$ is a favourable module. To prove the spanning property we use the action of $U(\mathfrak{n}^+)$ on $V(\lambda)^a$ to obtain certain relations in $V(\lambda)^a$, see Subsection 3.3. This also implies the statement on the generators of $I(\lambda)$. Here we adapt the ideas of [FFL11a]. Note that our proof only depends on the Hasse diagram.

In the introduction in Subsection 1.3 we already compared the basis of $V(\lambda)^a$ obtained in the second paper parametrized by $P_{\mathbb{N}}(\lambda)$ with the basis of $V(\lambda)^a$ parametrized by the lattice points of the FFL polytope in type A_n , $\lambda = m\omega_i$. We obtained that these bases are not the same. Another difference is the Minkowski sum property of the polytope. Assume \mathfrak{g} is of type A_4 , then the number of lattice points in $P(\omega_1) + P(\omega_2) + P(\omega_3) + P(\omega_4)$ is 1023, where the dimension of $V(\omega_1 + \omega_2 + \omega_3 + \omega_4)$ is 1024. In comparison the FFL polytopes satisfy in general for all $\lambda, \mu \in P^+$:

$$\text{FFL}_{\mathbb{N}}(\lambda) + \text{FFL}_{\mathbb{N}}(\mu) = \text{FFL}_{\mathbb{N}}(\lambda + \mu).$$

Note that if \mathfrak{g} is of type C_n and we consider $\omega_i, 2 \leq i \leq n$ we also have $\langle \omega_i, \theta^\vee \rangle = 1$ but we do not have $\dim V(\omega_i) = P_{\mathbb{N}}(\omega_i)$. In the cases of $G_2, \omega_1, F_4, \omega_4$ and B_n, ω_1 this is also not the case. But we were able to slightly rewrite the Hasse diagram to obtain a polytope with the desired properties. See the appendix in 3 for some examples of Hasse diagrams. The problem in these cases is the following: there is a root $\beta \in R^+$ with $f_\beta v_{\omega_i}^a \neq 0$ such that $\beta - \alpha_k, \beta - 2\alpha_k \in R^+$ for some simple root $\alpha_k \neq \alpha_i$ and for the action of the root vectors we have $f_{\beta - \alpha_k} v_{\omega_i}^a \neq 0, f_{\beta - 2\alpha_k} v_{\omega_i}^a \neq 0$. For a suitable $\ell \geq 2$ we have

$$\begin{aligned} e_{\alpha_k}^2 f_\beta^\ell v_{\omega_i}^a &= e_{\alpha_k} (\ell f_{\beta - \alpha_k}^1 f_{\beta_k}^{\ell-1}) v_{\omega_i}^a = \\ c_0 \ell f_{\beta - 2\alpha_k}^1 f_{\beta - \alpha_k}^0 f_\beta^{\ell-1} v_{\omega_i}^a &+ c_1 \ell (\ell - 1) f_{\beta - \alpha_k}^2 f_\beta^{\ell-2} v_{\omega_i}^a \text{ in } V(\omega_i)^a, \end{aligned} \quad (2)$$

with $c_0 = c_{\beta-\alpha_k, \alpha_k} c_{\beta, \alpha_k}$ and $c_1 = c_{\beta-\alpha_k, \alpha_k}^2$ where $c_{\beta-\alpha_k, \alpha_k}, c_{\beta, \alpha_k}$ are the structure constants corresponding to $[e_{\alpha_k}, f_{\beta-\alpha_k}]$ and $[e_{\alpha_k}, f_{\beta}]$ respectively. We emphasize that we obtain two elements by acting with e_{α} . If we were in the case of $\beta - 2\alpha_k \notin R^+$ we would get only one. This complicates the search of a suitable polytope.

In the cases of $\mathbf{G}_2, \omega_1, \mathbf{F}_4, \omega_4$ and \mathbf{B}_n, ω_1 we were able to solve this problem by rewriting the Hasse diagram into a new diagram where we use also non-simple positive roots to label the directed edges. For example see Subsection 3.4 for the changes in the case of \mathbf{B}_n, ω_1 . In the cases of $\mathbf{C}_n, \omega_k, k \geq 2$ we were not able to find a suitable polytope, since $k - 1$ of such problems described in (2) occur.

In the following we want to think about possible generalizations of our ideas. One immediate idea of a generalization would be to define the same polytope in other cases. As mentioned before, outside of the cases investigated in the second paper, the lattice points in $P(\omega_i)$ do not coincide with dimensions of certain fundamental modules.

Another idea is to adapt the right-hand side of the inequalities in (6.2), for example if \mathfrak{g} is of type \mathbf{E}_8 and we consider the weight ω_8 . Then $\langle \omega_8, \theta^\vee \rangle = 2$, and let

$$P(\omega_8) = \{(s_\beta) \in \mathbb{R}_{\geq 0}^N \mid \sum_{\beta \in \mathbf{p}} s_\beta \leq 2 \forall \mathbf{p} \in \mathbf{D}, \quad s_\beta \leq 0 \text{ if } f_\beta v_{\omega_8} = 0\}$$

be the corresponding polytope. Then we have again $|P_{\mathbb{N}}(\omega_8)| > \dim V(\omega_8)$. For all simple Lie algebras and fundamental weights ω_i with $\langle \omega_i, \theta^\vee \rangle = 2$ this approach fails.

The next generalization of the polytope works in some cases, where the normality is not given anymore by the results in Subsection 3.2. At first, we consider more paths. Instead of requiring that a Dyck path starts at the highest root and end in a simple root, we allow paths to start at arbitrary roots β . The right-hand sides of the corresponding inequalities will be adapted by the value of $\langle \omega_i, \beta^\vee \rangle$. Secondly one should allow the coefficients c_β (of s_β) in the describing inequalities to be greater than 1, see Subsection 4.5 in the case of \mathbf{B}_3 . Also in [Gor15b] in the case of \mathbf{D}_4 this approach works. Nevertheless, in these cases the interpretation of the inequalities as paths is not stated and rather complicated. An approach would be to identify a coefficient $c_\beta > 1$ of s_β in some inequality with a weighted loop \cup_{c_β} at the vertex β in the Hasse diagram.

As mentioned the first approach of considering more paths leads us to the case of \mathbf{B}_n .

6.3. Monomial bases and PBW filtration in type B. In this section we fix \mathfrak{g} to be of type \mathbf{B}_n and $\lambda = m\omega_i, m \in \mathbb{N}, 1 \leq i \leq n$ a multiple of a fundamental weight. Apart from the results stated in Main Theorem 3 we conjecture a basis of $V(\lambda)^a$ in the cases of $\lambda = m\omega_i, 4 \leq i \leq n$. We shall describe the polytope and the reason why we think this conjecture is true. As before the polytope is described by paths in the Hasse diagram. We build the Hasse diagram slightly different. The shape is the same but we do not use directed arrows. The paths are certain subsets of $\mathcal{P}(R^+)$, the power set of R^+ , were we distinguish between type 1 and type 2 paths, we call them

again Dyck paths. The Dyck paths of type 1 are similar to the Dyck paths described in [FLL11a] in a certain area of the Hasse diagram of type B_n (see Subsection 4.4, also for more details on the Dyck paths). A Dyck path of type 2 is the disjoint union of two Dyck paths of type 1 with some extra conditions. We consider the set of Dyck paths $\mathbf{D} = \mathbf{D}^{\text{type 1}} \cup \mathbf{D}^{\text{type 2}}$ and adjust the right-hand side of the corresponding inequalities, in particular we define

$$P(m\omega_i) = \left\{ (s_\beta) \in \mathbb{R}_{\geq 0}^N \mid \forall \mathbf{p} \in \mathbf{D} : \sum_{\beta \in \mathbf{p}} s_\beta \leq M_{\mathbf{p}}(m\omega_i), s_\beta \leq 0 \text{ if } f_{\beta v_{\omega_i}} = 0 \right\},$$

where we set

$$M_{\mathbf{p}}(m\omega_i) = \begin{cases} m & \text{if } \mathbf{p} \in \mathbf{D}^{\text{type 1}} \\ m\langle \omega_i, \theta^\vee \rangle & \text{if } \mathbf{p} \in \mathbf{D}^{\text{type 2}}. \end{cases}$$

We have proved the following facts on this polytope. The lattice points $P_{\mathbb{N}}(m\omega_i)$ parametrize a spanning set of $V(m\omega_i)^a$ for all $1 \leq i \leq n$. The polytope is normal in the cases of $m\omega_1$ and $m\omega_2$ and we show with a similar proof as sketched in Subsection 6.2 that $P_{\mathbb{N}}(m\omega_i)$ parametrizes a basis of $V(m\omega_i)^a$ for $i = 1$ and $i = 2$. But, in general the polytope is not normal in the cases of ω_i , where $3 \leq i \leq n$. For example, the polytope $P(\omega_3)$ has a rational vertex. Nevertheless we prove that $P_{\mathbb{N}}(\omega_3)$ parametrizes a basis of $V(\omega_3)^a$ and also that $P_{\mathbb{N}}(2\omega_3)$ parametrizes a basis of $V(2\omega_3)^a$. Furthermore we show with much effort that $P(2m\omega_3)$ is a normal polytope. We construct a basis of $V(m\omega_3)^a$ parametrized by $P_{\mathbb{N}}(m\omega_3)$, note that m is arbitrary and not necessary a multiple of 2, by taking Minkowski sums of $P_{\mathbb{N}}(\omega_3)$ and $P_{\mathbb{N}}(2\omega_3)$.

Based on this result we conjecture that $P_{\mathbb{N}}(m\omega_i)$ parametrizes a basis of $V(m\omega_i)^a$ also in the cases where $4 \leq i \leq n$. If the conjecture would be true, we also could describe the generators of the ideal $I(m\omega_i)$, where $V(m\omega_i)^a \cong S(\mathfrak{n}^-)/I(m\omega_i)$.

6.4. Degree cones and monomial bases. We want to discuss a new polytope conjecturally parametrizing a new monomial basis of $V(\lambda)$ in the case of \mathfrak{sl}_5 . We consider the following reduced expression $\underline{w}_0 = s_1 s_2 s_1 s_4 s_3 s_2 s_1 s_4 s_3 s_2$. The corresponding convex order is

$$\alpha_{1,1} < \alpha_{1,2} < \alpha_{2,2} < \alpha_{4,4} < \alpha_{1,4} < \alpha_{2,4} < \alpha_{3,4} < \alpha_{1,3} < \alpha_{2,3} < \alpha_{3,3},$$

where $\alpha_{i,j}$ denotes the root $\alpha_i + \dots + \alpha_j$, $1 \leq i \leq j \leq 4$. Denote the corresponding PBW root vectors by $f_{i,j}$. Any $\mathbf{d} \in \mathcal{D}_{\underline{w}_0}^q$ implies $I^{\mathbf{d}}(\omega_i)$, $1 \leq i \leq 4$ is monomial, since

$$\begin{aligned} \deg f_{1,4} + \deg f_{2,3} &> \deg f_{1,3} + \deg f_{2,4}, \\ \deg f_{2,4} + \deg f_{1,2} &> \deg f_{1,4} + \deg f_{2,2}, \\ \deg f_{2,3} + \deg f_{1,2} &> \deg f_{1,3} + \deg f_{2,2}, \\ \deg f_{1,4} + \deg f_{3,3} &> \deg f_{1,3} + \deg f_{3,4}, \\ \deg f_{2,4} + \deg f_{3,3} &> \deg f_{2,3} + \deg f_{3,4}. \end{aligned}$$

The choice in all other weight spaces is obvious since $\mathcal{D}_{\underline{w}_0}^q \subset \mathcal{D}$. Hence we obtain a monomial basis of $V^{\mathbf{d}}(\omega_i)$. The interesting point is the following: the monomials in $S(\mathfrak{n}^-)$ describing the basis of $V^{\mathbf{d}}(\omega_3)$ are the same as the

monomials describing the basis of $V^a(\omega_3)$ obtained in the second paper, in particular these are

$$f_{1,3}f_{2,4}, f_{1,3}f_{3,4}, f_{2,3}f_{3,4}.$$

The monomials in $S(\mathfrak{n}^-)$ describing the basis of $V^{\mathbf{d}}(\omega_2)$ are a mix of monomials described by the FFL basis of $V^a(\omega_2)$ and monomials describing the basis obtained in the second paper of $V^a(\omega_2)$, in particular these are

$$f_{1,3}f_{2,4}, f_{1,4}f_{2,2}, f_{1,3}f_{2,2}.$$

Let us consider the following polytope. We enumerate positive roots by

$$\alpha_1, \alpha_{1,2}, \alpha_{2,2}, \alpha_{1,3}, \alpha_{2,3}, \alpha_{3,3}, \alpha_{1,4}, \alpha_{2,4}, \alpha_{3,4}, \alpha_{4,4}.$$

Let $P(a_1, a_2, a_3, a_4)$ be the polytope in \mathbb{R}^{10} defined by the following inequalities:

- (1) $x_1, x_2, \dots, x_{10} \geq 0$
- (2) $x_1 \leq a_1$
- (3) $x_3 \leq a_2$
- (4) $x_6 \leq a_3$
- (5) $x_{10} \leq a_4$
- (6) $x_1 + x_2 + x_3 \leq a_1 + a_2$
- (7) $x_1 + x_2 + x_4 + x_5 + x_6 \leq a_1 + a_2 + a_3$
- (8) $x_1 + x_2 + x_4 + x_5 + x_6 + x_7 + x_{10} \leq a_1 + a_2 + a_3 + a_4$
- (9) $2x_1 + 2x_2 + x_3 + x_4 + x_5 + 2x_6 + x_7 + x_8 + x_9 + x_{10} \leq 2a_1 + 2a_2 + 2a_3 + a_4$
- (10) $x_1 + x_2 + x_6 + x_7 + x_8 + x_9 + x_{10} \leq a_1 + a_2 + a_3 + a_4$
- (11) $2x_1 + 2x_2 + x_3 + x_4 + 2x_5 + 2x_6 + x_7 + x_8 + x_{10} \leq 2a_1 + 2a_2 + 2a_3 + a_4$
- (12) $x_1 + x_2 + x_5 + x_6 + x_7 + x_8 + x_{10} \leq a_1 + a_2 + a_3 + a_4$
- (13) $x_1 + x_2 + x_3 + x_5 + x_6 + x_8 + x_{10} \leq a_1 + a_2 + a_3 + a_4$
- (14) $x_3 + x_6 + x_8 + x_9 + x_{10} \leq a_2 + a_3 + a_4$
- (15) $x_3 + x_5 + x_6 \leq a_2 + a_3$
- (16) $2x_1 + 2x_2 + x_3 + x_4 + 2x_5 + 3x_6 + x_7 + x_8 + x_9 + x_{10} \leq 2a_1 + 2a_2 + 3a_3 + a_4$
- (17) $x_6 + x_9 + x_{10} \leq a_3 + a_4$
- (18) $x_1 + x_2 + x_3 + x_5 + 2x_6 + x_8 + x_9 + x_{10} \leq a_1 + a_2 + 2a_3 + a_4$
- (19) $x_1 + x_2 + x_5 + 2x_6 + x_7 + x_8 + x_9 + x_{10} \leq a_1 + a_2 + 2a_3 + a_4$
- (20) $x_1 + x_2 + x_3 + x_4 + 2x_5 + 2x_6 + x_7 + x_8 + x_{10} \leq a_1 + 2a_2 + 2a_3 + a_4$
- (21) $x_1 + x_2 + x_3 + x_6 + x_8 + x_9 + x_{10} \leq a_1 + a_2 + a_3 + a_4$
- (22) $x_1 + x_2 + x_4 + x_5 + 2x_6 + x_7 + x_9 + x_{10} \leq a_1 + a_2 + 2a_3 + a_4$
- (23) $x_1 + x_2 + x_3 + x_5 + x_6 \leq a_1 + a_2 + a_3$
- (24) $x_3 + x_5 + 2x_6 + x_8 + x_9 + x_{10} \leq a_2 + 2a_3 + a_4$
- (25) $x_3 + x_5 + x_6 + x_8 + x_{10} \leq a_2 + a_3 + a_4$
- (26) $x_1 + x_2 + x_3 + x_4 + 2x_5 + 3x_6 + x_7 + x_8 + x_9 + x_{10} \leq a_1 + 2a_2 + 3a_3 + a_4$
- (27) $x_1 + x_2 + x_3 + x_4 + x_5 + 2x_6 + x_7 + x_8 + x_9 + x_{10} \leq a_1 + 2a_2 + 2a_3 + a_4$

The polytope $P(1, 1, 1, 1)$ has 36 facets, so it is isomorphic neither to the FFL polytope of type \mathbf{A}_4 , nor to any string polytope for \mathbf{A}_4 .

Conjecture. *The polytopes $P(a_1, a_2, a_3, a_4)$ are normal and satisfy the Minkowski property. Further let $\lambda = a_1\omega_1 + a_2\omega_2 + a_3\omega_3 + a_4\omega_4 \in P^+$, we have $P_{\mathbb{N}}(a_1, a_2, a_3, a_4)$ parametrizes a monomial basis of $V^{\mathbf{d}}(\lambda)$ and $I^{\mathbf{d}}(\lambda)$ is a monomial ideal.*

If the conjecture is true, a natural question is, if there are similar polytopes for A_n , $n \geq 5$, or do we obtain similar polytopes for $n = 4$ for a different choice of monomials.

Other questions we are working on are: for example, what is special about reduced expressions implying a normal polytope such that its lattice points parametrize a certain basis? Do we have an interpretation of our results in terms of the Hall algebra of quiver representations? How many quantum degree cones exist for a fixed simple Lie algebra and how to classify them?

REFERENCES

- [AB04] V. Alexeev and M. Brion. Toric degenerations of spherical varieties. *Selecta Math. (N.S.)*, 10(4):453–478, 2004.
- [ABS11] F. Ardila, T. Bliem, and D. Salazar. Gelfand-Tsetlin polytopes and Feigin-Fourier-Littelmann-Vinberg polytopes as marked poset polytopes. *J. Combin. Theory Ser. A*, 118(8):2454–2462, 2011.
- [BBDF] T. Backhaus, L. Bossinger, C. Desczyk, and G. Fourier. The degree of the Hilbert-Poincaré polynomial of PBW-graded modules. *Comptes Rendus Mathématique*, 352(12):959 – 963, 2014.
- [BD] T. Backhaus and C. Desczyk. PBW filtration: Feigin-Fourier-Littelmann modules via Hasse diagrams. *Journal of Lie Theory* 25 (2015), No. 3, 815–856.
- [BK] T. Backhaus and D. Kus. The PBW filtration and convex polytopes in type B arXiv:1504.06522.
- [B08] A. Barvinok. Integer points in polyhedra. *Zurich Lectures in Advanced Mathematics. European Mathematical Society (EMS)*, Zürich, 2008.
- [BF] R. Biswal and G. Fourier. Minuscule Schubert varieties: Poset polytopes, PBW-degenerated Demazure modules, and Kogan faces. arXiv:1410.1126, Algebras and Representation Theory (to appear).
- [BZ89] A. D. Berenstein and A. V. Zelevinsky. Tensor product multiplicities and convex polytopes in partition space. *J. Geom. Phys.*, 5(3):453–472, 1989.
- [BZ93] A. Berenstein and A. Zelevinsky. String bases for quantum groups of type A_r . In *I. M. Gelfand Seminar*, volume 16 of *Adv. Soviet Math.*, pages 51–89. Amer. Math. Soc., Providence, RI, 1993.
- [BZ01] A. Berenstein and A. Zelevinsky. Tensor product multiplicities, canonical bases and totally positive varieties. *Invent. Math.*, 143(1):77–128, 2001.
- [Car05] R. W. Carter. Lie algebras of finite and affine type, volume 96 of *Cambridge Studies in Advanced Mathematics. Cambridge University Press*, Cambridge, 2005.
- [CF15] I. Cherednik and E. Feigin. Extremal part of the PBW-filtration and nonsymmetric Macdonald polynomials. *Adv. Math.*, 282:220–264, 2015.
- [CIFR12] G. Cerulli Irelli, E. Feigin, and M. Reineke. Quiver Grassmannians and degenerate flag varieties. *Algebra Number Theory*, 6(1):165–194, 2012.
- [CIFR13] G. Cerulli Irelli, E. Feigin, and M. Reineke. Degenerate flag varieties: moment graphs and Schröder numbers. *J. Algebraic Combin.*, 38(1):159–189, 2013.
- [CIL15] G. Cerulli Irelli and M. Lanini. Degenerate flag varieties of type A and C are Schubert varieties. *Int. Math. Res. Not. IMRN*, (15):6353–6374, 2015.
- [CILL] G. Cerulli Irelli, M. Lanini, and P. Littelmann. Degenerate flag varieties and Schubert varieties: a characteristic free approach. arXiv:1502.04590.
- [Fei11] E. Feigin. Degenerate flag varieties and the median Genocchi numbers. *Math. Res. Lett.*, 18(6):1163–1178, 2011.
- [Fei12] E. Feigin. \mathbb{C}_a^M degeneration of flag varieties. *Selecta Math. (N.S.)*, 18(3):513–537, 2012.
- [FFi13] E. Feigin and M. Finkelberg. Degenerate flag varieties of type A: Frobenius splitting and BW theorem. *Math. Z.*, 275(1-2):55–77, 2013.
- [FFJMT] B. Feigin, E. Feigin, M. Jimbo, T. Miwa, and Y. Takeyama. A $\phi_{1,3}$ -filtration of the Virasoro minimal series $M(p, p')$ with $1 < p'/p < 2$. *Publ. Res. Inst. Math. Sci.*, 44(2):213–257, 2008.
- [FFL13b] E. Feigin, G. Fourier, and P. Littelmann. Favourable modules: Filtrations, polytopes, Newton-Okounkov bodies and flat degenerations. arXiv:1306.1292, Transformation groups (to appear).
- [FFL11a] E. Feigin, G. Fourier, and P. Littelmann. PBW filtration and bases for irreducible modules in type A_n . *Transform. Groups*, 16(1):71–89, 2011.
- [FFL11b] E. Feigin, G. Fourier, and P. Littelmann. PBW filtration and bases for symplectic Lie algebras. *Int. Math. Res. Not. IMRN*, (24):5760–5784, 2011.

- [FFL13a] E. Feigin, G. Fourier, and P. Littelmann. PBW-filtration over \mathbb{Z} and compatible bases for $V(\lambda)$ in type A_n and C_n . *Springer Proceedings in Mathematics and Statistics*, 40:35–63, 2013.
- [FFiL14] E. Feigin, M. Finkelberg, and P. Littelmann. Symplectic degenerate flag varieties. *Canad. J. Math.*, 66(6):1250–1286, 2014.
- [FFR15] X. Fang, G. Fourier, and M. Reineke. PBW-type filtration on quantum groups of type A_n . arXiv:1503.05428, *Journal of Algebra* (to appear), 2015.
- [FM15] E. Feigin and I. Makedonskyi. Nonsymmetric Macdonald polynomials and PBW filtration: towards the proof of the Cherednik-Orr conjecture. *J. Combin. Theory Ser. A*, 135:60–84, 2015.
- [Fou14] G. Fourier. PBW-degenerated Demazure modules and Schubert varieties for triangular elements. arXiv:1408.6939, *Journal of Combinatorial Theory, Series A* (to appear).
- [Fou15] G. Fourier. New homogeneous ideals for current algebras: filtrations, fusion products and Pieri rules. *Moscow Mathematical Journal*, Volume 15 (1), pp. 49–72, 2015.
- [Fou16] G. Fourier. Marked poset polytopes: Minkowski sums, indecomposables, and unimodular equivalence. *J. Pure Appl. Algebra*, 220(2):606–620, 2016.
- [GL97] N. Gonciulea and V. Lakshmibai. Schubert varieties, toric varieties, and ladder determinantal varieties. *Ann. Inst. Fourier (Grenoble)*, 47(4):1013–1064, 1997.
- [Gor15b] A. Gornitskii. Essential signatures and canonical bases for irreducible representations of D_4 . arXiv:1507.07498, 2015.
- [Gor15a] A. Gornitskii. Essential signatures and canonical bases in irreducible representations of the group G_2 . *Mathematical Notes*, 97(1):30–41, 2015.
- [GT50] I. M. Gelfand and M. L. Tsetlin. Finite-dimensional representations of the group of unimodular matrices. *Doklady Akad. Nauk SSSR (N.S.)*, 71:825–828, 1950.
- [Hag14] C. Hague. Degenerate coordinate rings of flag varieties and Frobenius splitting. *Selecta Math. (N.S.)*, 20(3):823–838, 2014.
- [HK13] M. Harada and K. Kaveh. Toric degenerations, integrable systems, and Okounkov bodies. arXiv:1205.5249, *Inventiones Mathematicae* (to appear), 2013.
- [Hum72] J. E. Humphreys. Introduction to Lie algebras and representation theory. *Springer-Verlag*, New York, 1972. *Graduate Texts in Mathematics, Vol. 9*.
- [Jos95] A. Joseph. Quantum groups and their primitive ideals, volume 29 of *Ergebnisse der Mathematik und ihrer Grenzgebiete (3) [Results in Mathematics and Related Areas (3)]*. Springer-Verlag, Berlin, 1995.
- [K90] V. G. Kac. Infinite-dimensional Lie algebras. *Cambridge University Press, Cambridge, third edition*, 1990.
- [Kas90] M. Kashiwara. Crystalizing the q -analogue of universal enveloping algebras. *Comm. Math. Phys.*, 133(2):249–260, 1990.
- [Kas91] M. Kashiwara. On crystal bases of the q -analogue of universal enveloping algebras. *Duke Math. J.*, 63(2):465–516, 1991.
- [Kas96] M. Kashiwara. Similarity of crystal bases. In *Lie algebras and their representations (Seoul, 1995)*, volume 194 of *Contemp. Math.*, pages 177–186. Amer. Math. Soc., Providence, RI, 1996.
- [KK12] K. Kaveh and A. G. Khovanskii. Newton-Okounkov bodies, semigroups of integral points, graded algebras and intersection theory. *Ann. of Math. (2)*, 176(2):925–978, 2012.
- [Kir] V. Kiritchenko. Geometric mitosis. arXiv:1409.6097, 2014.
- [KM05] M. Kogan and E. Miller. Toric degeneration of Schubert varieties and Gelfand-Tsetlin polytopes. *Adv. Math.*, 193(1):1–17, 2005.
- [Kos59] B. Kostant. A formula for the multiplicity of a weight. *Trans. Amer. Math. Soc.*, 93:53–73, 1959.
- [K13b] D. Kus. Kirillov-Reshetikhin crystals, energy function and the combinatorial R-matrix. arXiv:1309.6522, *Journal of Algebraic Combinatorics* (to appear).
- [K13a] D. Kus. Realization of affine type A Kirillov-Reshetikhin crystals via polytopes. *J. Combin. Theory Ser. A*, 120(8):2093–2117, 2013.

- [Lit94] P. Littelmann. A Littlewood-Richardson rule for symmetrizable Kac-Moody algebras. *Invent. Math.*, 116(1-3):329–346, 1994.
- [Lit95] P. Littelmann. Paths and root operators in representation theory. *Ann. of Math. (2)*, 142(3):499–525, 1995.
- [Lit98] P. Littelmann. Cones, crystals and patterns. *Transform. Groups*, 3(2):145–179, 1998.
- [LS91] S. Levendorskiĭ and Y. Soibelman. Algebras of functions on compact quantum groups, Schubert cells and quantum tori. *Comm. Math. Phys.*, 139(1):141–170, 1991.
- [Lus90a] G. Lusztig. Canonical bases arising from quantized enveloping algebras. *J. Amer. Math. Soc.*, 3(2):447–498, 1990.
- [Lus90b] G. Lusztig. Canonical bases arising from quantized enveloping algebras. II. *Progr. Theoret. Phys. Suppl.*, (102):175–201 (1991), 1990. Common trends in mathematics and quantum field theories (Kyoto, 1990).
- [Lus10] G. Lusztig. Introduction to quantum groups. *Reprint of the 1994 edition. Modern Birkhäuser Classics*. Birkhäuser/Springer, New York, 2010.
- [P94] P. Papi. A characterization of a special ordering in a root system. *Proc. Amer. Math. Soc.* 120(3), 661–665, 1994.
- [Sta86] R. P. Stanley. Two poset polytopes, *Discrete Comput. Geom.*, 1(1), 9–23, 1986.
- [Vin05] E. Vinberg. On some canonical bases of representation spaces of simple Lie algebras. Conference talk, Bielefeld, 2005.

ERKLÄRUNG ZUM EIGENANTEIL

In der Reinen Mathematik ist die genaue Aufgliederung in exakte Anteile, der jeweiligen Autoren einer Publikation, im Allgemeinen schwer. Die Ideen werden oft gemeinsam entwickelt und umgesetzt. Daher ist es üblich, dass alle Autoren gleichberechtigte Erstautoren sind. Die Reihenfolge der Autoren ist immer alphabetisch und hat keine andere Bedeutung.

Die erste Publikation *The degree of the Hilbert-Poincaré polynomial of PBW-graded modules*, siehe 2, wurde von Lara Bossinger, Christian Desczyk, Ghislain Fourier und mir angefertigt. Die Arbeit entstand fast ausschließlich in Zusammenarbeit und gemeinsamen Diskussionen. Daher ist der Anteil jedes Autors mit 25% zu werten.

Die zweite Publikation *PBW filtration: Feigin-Fourier-Littelmann modules via Hasse diagrams*, siehe 3, stammt von Christian Desczyk und mir. Diese Arbeit wurde ebenfalls weitestgehend gemeinsam erarbeitet. Einzelne Teile lassen sich jedoch aufgliedern. Die Arbeit zu der Lie Algebra vom Typ F_4 lässt sich Christian Desczyk zuordnen. Die Arbeit zu den Lie Algebren E_6 , E_7 und G_2 wurde von mir geleistet. Weiterhin lassen sich die Rechnungen zu den Fällen A_n , D_n mehr Christian Desczyk und die Arbeit zu der Spanneigenschaft mehr mir zuordnen. Daher liegt der Anteil beider Autoren bei 50%.

Die dritte Publikation *The PBW filtration and convex polytopes in type B*, siehe 4, wurde von Deniz Kus und mir ebenfalls zusammen erarbeitet. Auch hier liegt der Anteil beider Autoren bei 50%.

Die vierte Arbeit *Degree cones and monomial bases for Lie algebras and Quantum groups*, siehe 5, ist bisher weder publiziert noch im Begutachtungsverfahren. Sie entstand in Zusammenarbeit mit Xin Fang und Ghislain Fourier in vielen Diskussionen und Videokonferenzen. Der Anteil jedes Autors, also auch mein Anteil, liegt bei einem Drittel.

ERKLÄRUNG ZUR DISSERTATION

Ich versichere, dass ich die von mir vorgelegte Dissertation selbständig angefertigt, die benutzten Quellen und Hilfsmittel vollständig angegeben und die Stellen der Arbeit - einschließlich Tabellen, Karten und Abbildungen -, die anderen Werken im Wortlaut oder dem Sinn nach entnommen sind, in jedem Einzelfall als Entlehnung kenntlich gemacht habe; dass diese Dissertation noch keiner anderen Fakultät oder Universität zur Prüfung vorgelegen hat; dass sie - abgesehen von unten angegebenen Teilpublikationen - noch nicht veröffentlicht worden ist sowie, dass ich eine solche Veröffentlichung vor Abschluss des Promotionsverfahrens nicht vornehmen werde. Die Bestimmungen der Promotionsordnung sind mir bekannt. Die von mir vorgelegte Dissertation ist von Prof. Dr. Peter Littelmann betreut worden.

Köln, November 2015

(Teodor Backhaus)

1. *The degree of the Hilbert–Poincaré polynomial of PBW-graded modules.* In collaboration with Lara Bossinger, Christian Desczyk and Ghislain Fourier. *Comptes Rendus Mathématique*, 352 (12): 959 - 963 (2014).
2. *PBW filtration: Feigin–Fourier–Littelmann modules via Hasse diagrams.* In collaboration with Christian Desczyk. *Journal of Lie theory*, 25 (3): 815 - 856 (2015).
3. *The PBW filtration and convex polytopes in type B.* In collaboration with Deniz Kus. Submitted to *Transformation Groups*.

Persönliches

Vorname Karl Josef Teodor
Nachname Backhaus
Staatsangehörigkeit Deutsch
Geburtstag 20. Januar 1987
Adresse Kuenstraße 39, 50733 Köln
E-Mail teobackhaus@googlemail.com
Telefon (0221) 9761 6033
Sprachen Deutsch (Muttersprache), Englisch (fließend), Französisch (Anfänger), Niederländisch (Anfänger)

Büro

Adresse Weyertal 86-90, 50931 Köln
E-Mail tbackha@math.uni-koeln.de
Telefon (0221) 470-4297
Position Wissenschaftlicher Mitarbeiter
Homepage www.mi.uni-koeln.de/~tbackha

Universitärer Werdegang

- 2013 – Gegenwart **Doktorand in Mathematik**, *Titel der Arbeit: Monomial bases and PBW filtration in representation theory*, Universität zu Köln, Deutschland, Betreuer: Professor Dr. Peter Littelmann.
Finanziert durch das DFG Schwerpunktprogramm SPP 1388 'Representation Theory'.
- 2010 – 2013 **Mathematik M.Sc.**, *Titel der Arbeit: PBW-Filtrierung und Basen für irreduzible G_2 Moduln*, Universität zu Köln, Deutschland.
Nebenfach: Informatik
- 2007 – 2010 **Mathematik B.Sc.**, Universität zu Köln, Deutschland.
Nebenfach: Informatik

Schulischer Werdegang

- 2003 – 2006 **Allgemeine Hochschulreife**, *Albert-Schweitzer-Schule Alsfeld*.
- 1997 – 2003 **Mittlerer Schulabschluss**, *Gesamtschule Niederaula*.
- 1993 – 1997 **Grundschule**, *Herzbergschule in Breitenbach am Herzberg*.

Beruflicher Werdegang

- 2013 – Gegenwart **Wissenschaftlicher Mitarbeiter**, Universität zu Köln.
- 2009 – 2013 **Studentische Hilfskraft**, *Tutor*, Homepageadministrator, Universität zu Köln.
- 2006 – 2007 **Zivildienst**, *Integrative Gesamtschule Rodenkirchen*.